



MANUAL OF QUALITY CONTROL PROCEDURES FOR VALIDATION OF OCEANOGRAPHIC DATA

Prepared by: CEC: DG-XII, MAST
and IOC: IODE

CEC-IOC: MANUAL OF QUALITY CONTROL PROCEDURES FOR VALIDATION OF OCEANOGRAPHIC DATA

CONTENTS

SECTION 1

	Page
1.1 Preface	3
1.2 Acknowledgements	4
1.3 Liability for Use	4
1.4 Introduction	4
1.5 How to Use this Manual	10

SECTION 2 - DOCUMENTS BOUND IN SEQUENCE

2.1 The Acquisition, Calibration & Analysis of CTD Data, 1998	17
2.2 UKOOA Recommended Procedures for Validation & Documentation of Oil Company Metocean Data, 1987	98
2.3 Seventh Session of the Drifting Buoy Co-operation Panel, 1991	203
2.4 Manual of Quality Control Algorithms S-, Procedures for Oceanographic Data going into International Oceanographic Data Exchange, 1989	219
2.5 In the Pursuit of High-Quality Sea-Level Data, 1991	259
2.6 Data Quality Control at the TOGA Subsurface Data Centre, 1990	273
2.7 Guidelines for the General Bathymetric Chart of the Oceans, 1991	285
2.8 GTSP Real-Time Quality Control Manual, 1990	305
2.9 Brief Synopsis of Procedures at the ICES Oceanographic Data Centre, Copenhagen, 1991	433
APPENDIX 1 - BIBLIOGRAPHY	436

1.1 PREFACE

This manual provides the reader with a selection of existing standards, procedures, and advice concerning data quality control, and data validation. The procedures presented in this manual have been used by experienced research groups, and have proved to be useful. These documents are now combined as a single volume, with the agreement of the original groups that developed them. The purpose of this is to provide researchers, project administrators, and data managers with guidance on good practice. The user is invited to review methods which have worked before, and to adopt these methods, or to adapt them to special requirements.

Data quality control, or data validation, is a stage in data management which is essential whenever data are used by any individual or group other than the originators of the data. It is distinct from the instrument calibration, sensor checks, field deployment checks, and quality control of laboratory analysis. These procedures are carried out by the data gatherer, who records the results for her or his own use. After the data have been analysed by the originating group, they are often shared between scientists in the same programme, transferred to a project data base, or national data centre, used by other scientists, and stored in a permanent computer archive where they can be retrieved for subsequent use. In these latter stages of transfer and re-use the concept of data quality control is vital. With the recent growth in large scale collaborative oceanographic research programmes both in Europe and globally, quality control of data is essential. Without it data from different sources cannot be combined or re-used to gain the advantages of integration, synthesis, and the development of long time series.

Data quality control information tells users of the data in a brief way how it was gathered, how it was checked, processed, what algorithms have been used, what errors were found, and how the errors have been corrected or flagged.

Since it is impossible to provide all the QC information which could be required by all possible users of the data, the minimum criterion is that there should be enough information to provide indicators of previous steps and corrections, so that the user can track back and find the details. In short, there should be a QC audit trail. Most data users would not have to use this audit trail, but its existence gives confidence that certain procedures and checks have been applied, and they could be verified if necessary.

It is not possible to provide rigid standards of QC for all data types which are applicable in all oceanographic and climatic conditions, and for all purposes. Some checks depend upon presumed average climatic conditions, upon presumed accuracy of instruments, or acceptable levels of noise, or desired accuracy of the final output. Researchers and data users will therefore wish to consider the basic principles underlying the procedures suggested here, but may wish to alter thresholds, the distance of outliers requiring flagging, etc. If the user of this manual modifies or improves a quality control procedure whilst checking a data set, then this modification should be recorded with the quality control information provided to the next user of the data, or to the data bank.

This first edition of the QC Manual has been developed jointly by the MAST Programme of DG XII in the Commission of the European Community and the Committee for International Oceanographic Data and Information Exchange of the Intergovernmental Oceanographic Commission. We have included the parameters which seemed to have adequately developed data QC standards based on experience. Standards are continuously being developed for a wider range of parameters, especially in the areas of marine chemistry, acoustics, biology, optics, and remote sensing. We hope to include additional material in later editions.

The QC procedures described in this manual refer in most cases to data gathering in a scientific research environment, where data are not transmitted for use in real-time or operational mode. Data users who wish to manipulate oceanographic data in an operational mode would have to adapt the procedures recommended here, for fully automatic, real-time applications.

The Editors

for CEC/DG XII
for IOC/IODE

1.2 ACKNOWLEDGEMENTS

The manuals, or sections of manuals, reproduced in Section 2 of this book have all been developed by other organisations. The Editors wish to express their gratitude and appreciation to these bodies for copyright permission to reproduce the relevant texts. We hope that this combined volume on Quality Control will bring this subject to the attention of a wider audience, and that the originators will receive due credit for their endeavour. The development of Quality Control procedures is a slow and usually thankless task: this acknowledgement expresses thanks.

We are grateful to the following organisations for the copyright permission to reproduce in whole or in part the following publications:

International Council of Scientific Unions, the Scientific Committee on Oceanic Research (published by UNESCO): The acquisition, calibration, and analysis of CTD data, 1988.

Health and Safety Executive (UK), and UK Offshore Operators' Association: UKOOA recommended procedures for validation and documentation of oil company metocean data, 1987. (prepared by Metocean Ltd.)

Drifting Buoy Co-operation Panel (Joint IOC and WMO) Summary Report of 7th Session.

Intergovernmental Oceanographic Commission, the Committee for International Oceanographic Data and Information Exchange, Task Team for Data Quality Control: Manual of quality control algorithms and procedures for oceanographic data going into International Oceanographic Data Exchange, 1989

Tropical Ocean Global Atmosphere project, TOGA Sea Level Centre In Pursuit of High Quality Sea Level Data.

Tropical Ocean Global Atmosphere project, TOGA Subsurface Data Centre. Data Quality Control at TOGA Subsurface Data Centre.

International Hydrographic Organization-] Intergovernmental Oceanographic Commission Guiding Committee for the General Bathymetric Chart of the Oceans: Guidelines for the General Bathymetric Chart of the Oceans, 1991.

Intergovernmental Oceanographic Commission, the Committee for the Global Temperature Salinity Pilot Project (Jointly with the World Meteorological Organisation and the Integrated Global Ocean Services System): GTSP real-time quality control manual, 1990.

ICES, Brief Synopsis of procedures at the ICES Oceanographic Data Centre, Copenhagen, 1991.

The Editors

for CEC/DC-XII
for IOC/IODE

1.3 LIABILITY FOR USE

The information contained in this manual is believed to be accurate and is published in good faith. No liability can be accepted by CEC-DG-XII, IOC, IODE, their component bodies, officers, or agents, for any loss, damage or injury suffered directly or consequently as a result of using the information in this manual. Many of the procedures described in this manual are best used in conjunction with other documents listed in the bibliography. In publishing the information set forth in this manual, the CECDC-XII, IOC-IODE, and the Editors and contributing organisations assume no liability not otherwise imposed by law.

1.4 INTRODUCTION

Investigations of marine environment often require complex and large national and international research programmes. Such programmes need a data management plan which includes details about the data quality control in addition to a scientific and measurement plan. This quality control comprises all actions of the data originator in connection with data collection and validation and quality tests of her or his own data set. Only after these tests should the data be included in a database or distributed to users via international or national data exchange.

Experience from complex investigation projects shows that standardisation and documentation of the procedures for data quality control are important. The IOC Committee on International Oceanographic Data and Information Exchange (IODE) noted in its resolution IOC/IODE-XII/R.11 (1986) the great importance of the preparation and co-ordination of decisions on international unification of procedures for oceanographic data quality control and it decided to establish the Task Team on Oceanographic Data Quality Control. The Task Team prepared a Draft Manual on data Quality Control Algorithms and Procedures. Subsequently, IOC and CEC agreed to collaborate (21 February 1991) and defined the objective of the Manual to be an easy to use source of state-of-the-art information, advice, and guidance on data quality control /assurance for oceanographers and other marine scientists, marine monitoring programmes, and marine data centres.

Since the first publication on drafting of some of the included documents there have been changes in the names of some countries and regions in eastern Europe and the former Soviet Union. This may also have resulted in changes to the names of research institutions. Original names compatible with the dates on the documents have been retained, since this makes clear the institutional background and responsibilities at the time.

Most QC procedures were developed and tested when tapes were the standard media of data transfer. Techniques described in the Manual should be adapted where necessary to apply to file editing and transfer through other media such as floppy disks, CD-ROM, or networks.

OBJECTIVES OF DATA QUALITY CONTROL

The objective of data quality control is to ensure the data consistency within a single data set and within a collection of data sets, and to ensure that the quality and errors of the data are apparent to the user, who has sufficient information to assess its suitability for a task.

VALIDATION OF METOCEAN DATA

The four major aspects of metocean data validation are:

- a) Instrumentation checks and calibrations which include calibration /checks of sensor response; tests on instrument or system electronics; and checks on data processing and recording equipment.
- b) The documentation of deployment parameters which includes definition of the location and duration of the measurements; method of deployment of the instrumentation; and sampling scheme used for the measurements.
- c) Automatic quality control of data which comprises a series of tests on the data to identify erroneous and anomalous values in order to establish whether the data have been corrupted in any way, either during initial measurement, or in copying or transmission to a user.
- d) Oceanographic and meteorological assessment which includes an assessment of the results of conditions a) to c); and an assessment of the oceanographic and meteorological 'reasonableness' of the data, comprising checks on expected patterns or trends and comparisons, with other data sources. Two levels of oceanographic and meteorological assessment are recognised; a lower level in which the assessment is mostly applied manually to the data set; and a higher level comprising more detailed investigation and further analysis of the data.

MINIMUM REQUIREMENTS FOR DATA VALIDATION

The data validation procedures specified in this document, at least up to the lower level of oceanographic or meteorological assessment, are considered to form the required standard for a validated data set. However, it is realised that in practice this requirement may not be fully realised. This does not mean that the aim of the specifications should be lowered; rather that the data should be related to this standard and any differences noted.

It should also be recognised that there are certain data validation procedures which must be applied to a data set, otherwise the integrity of the data is seriously compromised.

These procedures are:

- a) one full check or calibration of the instrument
- b) complete documentation of the deployment parameters
- c) timing checks on the raw and processed data
- d) absolute value checks on the raw and processed data
- e) a lower level oceanographic or meteorological assessment.

The measurement method and the data quality control procedure for a parameter are dependent on each other, because each measurement method and each parameter type need some special data quality control procedures in addition to the generic checks on timing, position etc. Data quality control procedures can be divided into procedures which are:

- a) applied by the owner or originator of data to improve the data consistency within the data set, and
- b) applied by a data manager to improve the data consistency within a data bank, or in a multi source data set.

Regarding the data quality control measures, the originator is responsible for the following:

- use of documented or international recommended standard measurement methods and equipment;
- national and international calibration of measurement methods and instruments;
- data validation according to results of calibration and intercalibration as well as in comparison with standard methods;
- information on temporal and spatial sampling;
- tests of fixed and computed limits, gaps and constant values;
- detection, correction, and flagging of spikes;
- detection, correction, and flagging of errors in position and time;
- documentation of the process of data sampling and validation, including any algorithm applied;
- documentation of QC checks carried out and their results.

When data are transferred from the originating group to a national or international data centre, it is sometimes required that the data are transformed into a standard exchange format used between data centres. The general experience of data centres is that the processing of data sets into standard exchange format is best carried out by the data centre itself, and the originator is only required to provide the data in a well-documented format which is acceptable to both the originator and the data centre. This avoids the introduction of further errors by requiring data originators to use unfamiliar software and formats.

The data quality procedures ensure the data consistency within a data bank. They include procedures for:

- test of format coding;
- check of incoming data set against location and identification errors;
- tests of fixed and computed limits;
- tests according to climatological standards e.g. Levitus, Asheville climatology;
- visual inspection;
- duplicates check;
- parameter screening;
- oceanographic and meteorological assessment.

BENEFITS OF DATA QUALITY CONTROL AND DOCUMENTATION

Many national and international programmes or projects like HELCOM, IGOSS, JGOFS, JMP, MAST, WOCE have or are carrying out investigations across a broad field of marine science. More are planned. In addition to these scientific programmes many research projects are carried out under commercial control. Large projects like offshore oil and gas production, deep sea drilling projects, shipping and fishery need complex information on the marine environment. Significant decisions are taken on the assumption that data are reliable and compatible, even when they come from many different sources.

The analysis and understanding of processes in the marine environment need the use of many data types. Both the number of parameters and the amount of data are very large. These data streams are gathered by projects, and stored in national and international data centres for different purposes. Many of these data streams are co-ordinated under the guidance of IODE. World, Regional and National Oceanographic Data Centres are the focal points of the IODE system and are managed using standardised international data exchange formats, e.g. GF-3, CRIB, BUFR, and programme formats developed internally by JMP, HELCOM, ICES, etc.

QUALITY ASSURANCE DOCUMENTS

Introduction

Quality Assurance Documents (QADs) summarise the data validation procedures applied to metocean data sets. They are essentially check lists indicating the procedures which have been undertaken in validating metocean data, and the source documents to which reference can be made for details of these procedures. In addition, any significant comments relating to the procedures can be stated. They therefore allow a rapid assessment to be made of the level to which data validation procedures have been applied to a particular data set.

A QAD, filled in as necessary, should be appended to each individual metocean data set (or each discrete data sub-set for data collection programmes of long duration) upon completion of the data validation by the data gatherer. This QAD should then accompany this data set (or sub-set) wherever it is transferred, since it provides a definitive summary of the data validation applied to the data. Any subsequent validation procedures which are applied can then be incorporated into the QAD, and referenced.

QADS

QADs for some categories of metocean data are presented in Section 2.2 Figures 2.1 to 2.5. Two are provided for waves; one for non-directional (digital or analogue) data and one for directional data. Supplementary data, often measured in conjunction with currents and winds, are included on the respective forms, but need to be specified. While this requirement has resulted in some loss of detail for these supplementary data, it has allowed the forms to be standardised, and the number of forms to be kept to a minimum.

Responsibility for QAD completion

Initial responsibility for completing the QAD lies with the data gatherer, although it is the responsibility of the project co-ordinator or chief scientist to ensure that it has been filled in correctly. Responsibility for incorporating any subsequent validation undertaken (e.g. by a programme data manager) lies with the analyst performing those validation procedures, and these procedures must be adequately referenced.

Finally, responsibility for completing section F of the QAD headed 'Data Tape and Documentation for Banking' lies with the authority which is archiving the data, since these aspects refer to the data tape or disc submitted for banking.

QUALITY CONTROL PROCEDURES

Introduction

Quality control procedures for metocean data comprise two distinct aspects;

a) **Automatic Quality Control**

Automatic quality control consists of checks on individual data points or the internal consistency of the data. These checks are mostly applied by computer and provide tests for timing errors, physical limits of the data, constant values, rates of change, and the identification of gaps.

b) **Oceanographic and Meteorological Assessment**

Oceanographic and meteorological assessment is an assessment of the 'reasonableness' of the data set, comprising checks on expected patterns or trends, expected correlations between variables, and comparisons with other data sources.

Automatic Quality Control of Data

Automatic quality control requires that a distinction be made between the procedures for raw data and processed data, and checks have been defined for both types when these are available. Raw data in this context are considered to be a series of data points which is averaged or analysed to provide values of processed data. For certain instruments, particularly current meters and water level recorders, the sensor output is often processed data, since averaging is applied to the raw data internally and no raw data are available for checking. Thus for current and water level data, only processed data checks have been defined. However, for waves and the meteorological variables, when raw data are generally available for checking, tests are presented for both raw and processed data (see Section 2.2). The raw data tests are intended primarily to indicate any sensor malfunction, instability, or interference, in order to reduce potential corruption of the processed data.

The processed data checks are intended to identify erroneous or anomalous data, and have been formulated as a set of minimum requirements which are at the same time consistent and simple in their approach and application. These conditions to some extent conflict, as simple, universally applicable and unique tests are often too coarse in their resolution to be anything but gross error checks.

It is recognised that under certain circumstances these tests may be failed regularly, but this could be considered to indicate that the environmental conditions are more extreme than the expected average conditions for all sites, and thus notable. Conversely it may be that in other cases, more stringent site specific tests are required. In certain situations, therefore, it is accepted that the limits for these tests may need to be related more specifically to the expected environmental conditions at the measurement site, or developed from experience with the data.

No specific recommendation is given on the time and location of the application of the quality control procedures. However, generally, raw data checks are applied at the time of data collection, while processed data checks are applied onshore in the laboratory.

Oceanographic Assessment/Meteorological Assessment

The final validation procedure applied to metocean data involves the assessment of the oceanographic 'reasonableness' of the data, together with the integration of the results of the instrumentation checks, the documented deployment parameters, and the results of the quality control tests. In what follows, a distinction is made between lower and higher levels of oceanographic assessment, depending on the extent and depth of the investigation.

The lower level of oceanographic assessment includes the following elements. The oceanographic reasonableness of the data is initially assessed manually, by inspecting the data set for expected patterns or trends, for example: the occurrence of a semi-diurnal tidal signal for currents and water levels; an

increase in Hs and Tz accompanying an increase in wind speed; the occurrence of a distinctive 'envelope' of Hz/Tz values with no isolated outliers; a backing or veering wind direction during the passage of a depression. Comparisons of the main features of the data are also usually made with any data for the same area which are readily available from other sources, and comparisons with values expected from past climatic statistics.

Higher level oceanographic or meteorological assessment generally involves the application of further analytical methods (e.g. harmonic analysis to current and water level data), and detailed data-point by data-point comparisons with other available data. It also involves the validation of anomalous data for which the causes are not readily identifiable, and this may include the investigation of particular process-response mechanisms in the data (e.g. inertia] oscillations or internal tides in current meter data, wind speed - wave height correlations, the evolution and decay of wave spectra during the passage of depressions).

It is envisaged in the context of the minimum requirements for data validation, that any oceanographic assessment should include at least the lower level checks. Some higher level checks should also be undertaken if the data require them and are sufficient for them to be undertaken.

Quality Flagging and Editing Data

The policy on flagging data values to indicate their quality, reliability, or checks which have been carried out, or altering values after checking, filling in data gaps, etc., varies from project to project, and between different laboratories and data centres. Different degrees of automation, project deadlines, and types of subsequent use dictate different policies. There are two essential points: i) The actions taken should be explicitly clear to subsequent users of the data; and ii) It should be possible to recover the original data values if subsequent users do not accept the editing procedures applied. The documents included in this manual represent a cross-section of policies on flagging /editing, and users of this manual should decide which procedures are most suitable in their situation.

Some data managers and data centres do not apply any variable quality flags. Assuming that there is considerable time to carry out detailed checks, and the originating scientists can be contacted directly, every anomaly or query is referred back to the originator for clarification, or removal of the data. If a whole cruise or section is of doubtful quality, this information is recorded in the cruise information files.

A moderate level of flagging involves automatic checks indicating outliers, repeated values, excessive rates of change, departure from climatic statistics, etc., with flag numbers related to each kind of possible error. Where a full assessment is possible, further quality flags may be added on the basis of oceanographic and meteorological analysis. The assumption is that the data will be passed on to users with the quality flags, or, on retrieval from a data centre, the data manager can decide how to edit the data before passing it on to the end user.

If very large volumes of data are involved, all flagging of individual values will probably be automatic, although the statistical properties of the whole data set may be assessed to confirm the overall validity of the data and the relations between values. Reference back the originator would be impractical for purposes of checking single values, although it might be practical if a systematic error could be eliminated.

Where large volumes of data have to be used quickly, fully automatic flagging is applied, and, if the data have to be transferred for assimilation into models, corrections or deletions have to be applied automatically. If possible, the original data set should be retained and processed in delayed mode, with the application of further corrections and calibration data later so as to arrive at a more carefully quality controlled data set for archival and climatic use.

Where an explanation is found for an apparent error, corrections should be applied, and a record kept of the correction. Editing of archived data without reference back to instrument calibration, timing errors, or some other external source of correcting information, is strongly discouraged. Interpolating

single values, filling gaps, removing awkward values, etc., should be kept to an absolute minimum. In an archival data set it should always be possible to recover the original data values.

Data Banking

After data calibration and quality control by the originator, data should be transferred to a data bank, for permanent retention and further use. Banking enables data from many sources to be assembled into large regional merged data sets, and provides all scientists and other users with access to the data. The EC MAST Programme and IOC have consistent policies on data banking. Research programmes have varying policies on the delay or confidentiality period, if any, granted to originators for them to make early publication of research results based on the exclusive use of the data.

The global standard for exchange and banking of oceanographic data is stated in the joint manual (IOC/ICSU Manuals and Guides 9, 1991) "Manual on International Oceanographic Data Exchange". In general, data sets, accompanied by data documentation and quality control information, should be transferred in a well-described format to a National Oceanographic Data Centre (NODC). NODCs will apply further checks, archive the data, and transfer data either to external users, or between data centres on request. The data will also be transferred as an archival copy to one of the World Data Centres (Oceanography), which are located in USA (A), Russia (B), and China (D). A list of NODCs and the addresses of national oceanographic data co-ordinators is included in the manual.

Project leaders and chief scientists carrying out projects funded by the CEC or from the DG-XII MAST programme should obtain details of any special rules applying to distribution of data to other projects within the programme, and the timescales appropriate, to banking data.

1.5 HOW TO USE THIS MANUAL

- a) The existing manuals and guidelines provided by different organisations are reproduced in Section 2. Each manual or section of a manual contains the QC procedures for one or more data types. The specific pages on a given data type are not usually completely self-sufficient, since they depend upon general comments or assumptions set out at the beginning of the manual, agreed codes or abbreviations explained on other pages, or the calibration or quality control of other data channels described in the same manual. For this reason, each component manual in this book has been reproduced in *extenso*, with all sections and data types in consecutive order.

The QC Manual is paginated continuously straight through, and original document page numbers have been deleted. Internal cross-references within documents have been adapted where possible to refer to section numbers only.

Note: Always check the date of publication of the standard, **and the country of origin, or** sea area where it was developed. It may need **modification to suit modern instrumentation and your** sea area of interest.

- b) QC information on one data type may occur in several different sections of Section 2. To find the sections which refer to the data type which concerns you, please consult the following list:

SUBJECT/PARAMETER

Page

1. TEMPERATURE, SALINITY, CONDUCTIVITY

Hydrographic Stations, water bottle

IODE, Algorithms, vertical rate of change, 8	249
IODE, Temp, Sal, Conductivity, time rate of change. sec. 10	251
IODE, Station Co-ordinates	252
IODE, Repeated values of temp & pressure, 12.4, 12.5	254
JPOTS (see Bibliography)	436

SUBJECT/PARAMETER

Page

XBT, CTD, Buoy Sensor

Duplicates, GTSP 1990	315
Duplicate XBT Management (TOGA)	276,277
XBT Climatology Checks	279
GTSP QC Manual 1990, Profile Envelope	373
XBT Fall Rate Adjustments, IGOSS, 1991, (Bibliography)	436
DBCP	213
CTD Lowering Speed	42
Temp Range at Different Depths, TOGA	276
UNESCO 1988. SCOR Manual 54	17
JPOTS (see Bibliography)	436
Calibration	30
Data Processing	43
Guidelines for Exchange	53
Current Meter Ancillary Instruments, Metocean - Rate of Change	149
- Stationarity	151

Towed Undulating Systems

QC Information not available

Freezing Temp

246, 384

2. SURFACE WAVES

IODE, Wave Steepness	246
IODE, Wind-wave Direction	242
IODE, Data Range Checks 7.2, 7.3	247
IODE, Repeated Values. 12.1	253
Metocean, QAD for Directional Wave Data set	106
Metocean, QAD for Digital Non-directional Wave Data	105
Metocean, Appendix A. Quality Control for Non-Directional Wave Data	124
Metocean, Quality Control for Directional Wave Data	131

3. CURRENT VELOCITY

Metocean, QAD for Current Meter Data Set	107
Metocean. Current Meter Data. Appendix B	147

a) Recording Current Meter

IODE, Minimum Acceptable Current Speed, 4.3	243
IODE, Constant or Repeated Values, 12.2, 12.3	253
Metocean, Appendix B	147
Sense of Rotation of Currents, Metocean B9	153
Current Profile, Metocean B(153

b) EM Log

No QC Information Available

c) Ship's Track, Dead Reckoning

No QC Information Available

d) Argos Buoy

DBCP 203

e) Submersible Drifters, SOFAR, RAFOS, etc.

No QC Information Available

SUBJECT/PARAMETER

Page

f) Satellite Altimeter	
(See References in Bibliography)	436
g) ADCP, Moored	
Metocean, Appendix B1	142
(See References, TOGA)	436
h) ADCP, Ship-borne	
(See References, TOGA)	436

4. SEA LEVEL

IODE, Control Limits, 4.4, 4.5	243
PSMSL	436
Pacific Sea Level, Kilonsky & Caldwell, Instrumentation	263
Sea Level Reference Levels, Kilonsky & Caldwell	264
Rate of Change of Consecutive Values, Kilonsky & Caldwell	265
Monthly & Annual Data Assessment, Kilonsky & Caldwell	266
IODE QC Algorithms, Sea Level Repeated Values. 12.6	254
Metocean QAD for Water Level Data Set	108
Metocean Appendix C	167

5. TIDE

IODE, Tidal Amplitude, Maximum & Minimum Values Check, 4.6, 4.7 Check	243
Tidal Current Amplitudes, Metocean B9	153

6. DENSITY SIGMA

IODE QC Report, 5	245
GTSPQ QC Manual 1990. Test 2.10	402

7. SPATIAL CO-ORDINATES

Depth, GTSPQ 1990	359, 370
Bathymetry, GEBCO Guidelines, 1992	289
Oceanographic Station Depth Sequence, IODE, 1	237
Computation of Head Water, Metocean, B2	148
Fluctuation of Depth Record with Tide	152
Position	
GTSPQ QC Manual 1990. Test 1.3	343
Track Intersections, GEBCO, 1992, Navigation Documentation	296
Permissible Speed between Stations, IODE QC Algorithms, 11	252
Speed	
GTSPQ QC Manual 1990, Test 1.5	352
IODE, 11	252
Orientation, Direction	
Rate of Direction of Change of Current with Time, Metocean B	153
Stationarity Check on Current Direction	151
Direction of Wave Propagation, IODE	242

SUBJECT/PARAMETER	Page
8. TIME CO-ORDINATES	
GTSP Quality Control Manual, 1990, Test 1.2	322
Overall Timing Check, Number of Records Against Total Duration (Metocean B2)	148
Wind Data. Metocean D2	186
9. MARINE CHEMISTRY	436
No Agreed Standard QC Checks Available. See References in Bibliography for General Information & Recommendations	436
Hydrochemical Maximum Values	242
10. LIGHT	
Lowry, North Sea Project Data Base Manual (Bibliography)	436
11. ZOOPLANKTON	
Lowry, BOFS, (Bibliography)	436
ICES	435
12. BATHYMETRY, MARINE GRAVITY, MAGNETIC FIELD	
Digital Bathymetric Data, Single Beam Echo-sounders, GEBCO	289
Underway Magnetic Data, GEBCO	299
Underway Gravity Data, GEBCO	299
13. DRIFTING BUOY DATA	
DBCP. V11/3. Dec. 1991. Annex X11. Proposed Operating Working Procedures for Drifting Buoy Data Quality Control	203
DBCP, Air Pressure	213
14. MARINE WIND DATA	
Metocean QAD for Meteorological Wind Data	109
Metocean Appendix D	183
Drifting Buoy Wind Measurements, DBCP	213
15. STATION OR PLATFORM IDENTIFIER	
GTSP, QC Manual 1990. Test 1.1	319
16. SOUND VELOCITY	
Reference: Third Edition, Echo-sounding Correction Tables, GEBCO	298
17. GENERAL STATISTICS OF ERRORS	
Probability of Errors in Data Set Construction	227
Limiting Values of Parameters	241, 362
Homogeneity of Data	247

SECTION 2.1

**The acquisition, calibration,
and analysis of CTD data**

A Report, of SCOR Working Group 51

Unesco 1988

ISSN 0503-4299

Published in 1988
by the United Nations Educational,
Scientific and Cultural Organization
7 Place de Fontenoy, 75700 Paris

Printed in Unesco's workshops.

(C) Unesco 1988
Printed in France

Reproduction authorised, providing that appropriate mention is made of Unesco Technical Papers in Marine Science and voucher copies are sent to the Division of Marine Sciences.

ABSTRACT

In this report the members of SOON Working Group 51 have attempted to describe the total process involved in obtaining salinity and temperature profiles with modern CTD instruments. Their objective has been to provide a guide to procedures which will, if followed, lead to the acquisition of good and consistent data sets.

Successive chapters proceed from a discussion of the sensors, through their calibration and operation, to a detailed discussion of data processing options. The final chapter gives guidelines, adopted by ICES, for data exchange.

Five appendices go into more detail on topics which include, the design of an observational program, efficient low-pass filters, data exchange formats, the algorithm for Practical Salinity as a function of conductivity ratio, and lastly, the determination of the ice-point correction of thermometers.

RESUME

Dans le présent rapport les membres du Groupe de travail 51 du SCOR ont tenté de décrire dans son ensemble le processus permettant d'obtenir des profils de salinité et de température au moyen d'instruments CTD modernes. Leur objectif était d'établir un guide des procédures à suivre pour acquérir des séries de données valables et cohérentes.

Les différents chapitres sont consacrés à l'étude des capteurs, de leur étalonnage et de leur fonctionnement, et à un examen détaillé des options qui s'offrent en matière de traitement des données. Le dernier chapitre indique les directives adoptées par le CIEM pour l'échange des données.

Cinq appendices traitent de façon relativement détaillée des sujets suivants : la conception d'un programme d'observation, les filtres passe-bas efficaces, les formats d'échange des données, l'algorithme de la salinité pratique en fonction du rapport de conductivité et, enfin, la détermination de la correction à apporter à l'indication du point de congélation sur les thermomètres.

RESUMEN

En el presente informe los miembros del Grupo de Trabajo 51 del SCOR se proponen describir el proceso integral utilizado para obtener los perfiles de salinidad y temperatura con los modernos instrumentos CTD. Se trata de facilitar una guía (de los procedimientos que debidamente aplicados permiten obtener conjuntos de datos precisos y fiables).

En los diferentes capítulos se analizan los sensores, su calibración y su funcionamiento, para pasar luego a un debate detallado de las distintas opciones del procesamiento de datos. En el último capítulo figuran las directrices adoptadas por el ICES para el intercambio de datos.

En los cinco apéndices se analizan pormenorizadamente los siguientes temas: diseño de un programa de observación, filtros de paso bajo de buen rendimiento, formatos de intercambio de datos, el algoritmo de salinidad práctica como función del promedio de conductividad y, por último, la determinación de la corrección del punto de congelación de los termómetros.

РЕЗЮМЕ

В этом докладе члены Рабочей группы SCOR 51 попытались описать весь процесс, связанный с получением профилей температуры и солености при помощи современных инструментов для измерения электропроводности, температуры, глубины. Их цель заключалась в том, чтобы обеспечить руководство для процедур, которые, если их придерживаться, способствуют получению полных и совместимых серий данных.

В последующих главах рассматривается вопрос о калибровке работе датчиков, подробно излагаются альтернативные возможности обработки данных. В заключительной главе содержатся руководящие принципы, принятые МСИМ в отношении обмена данными.

В пяти дополнениях более подробно излагаются темы, включающие структуру программ наблюдения, эффективные фильтры с высокой пропускной способностью, форматы обмена данными, алгоритмы для практической солености в качестве функции коэффициента проводимости и, наконец, определение поправок термометров на точке замерзания воды.

ملخص

حاول أعضاء فريق عمل سكور 01 في هذا التقرير أن يصفوا جميع العميات اللازمة للحصول على جداول لبيان درجات اللوحة والحرارة بواسطة أجهزة م.ج.ع. (الموصلية ، درجة الحرارة ، العمق) الحديثة . وهم يستهدفون تقديم دليل لاجراءات عن شأنها أن تؤدي ، اذا ما اتبعت ، الى الحصول على مجموعات من البيانات الجيدة والثابتة .

وتتناول الفصول المتتالية موضوعات مختلفة بدءا بأجهزة الاحساس ومعايرتها وضريقة تشغيلها ، الى مناقشة مفصلة لخيارات معالجة المعلومات . وترد في الفصل الأخير مبادئ توجيهية اعتمدها المجلس الدولي لاستكشاف البحار (ايسكس) ، لتبادل المعلومات .

وثمة خمسة أبواب تتناول بمزيد من التفصيل موضوعات مثل تصميم برذائع للمراقبة ، والمرشحات عالية الكفاءة لتمرير الترددات المنخفضة فقط ، والأشكال البيانية لتبادل البيانات ، والخوارزمية المتعلقة بقياس اللوحة العملية كدالة لنسبة الموصلية ، وأخيرا ، تحديد عملية تصحيح الترمومترات عند نقطة الثلج .

摘 要

本文是海洋研究科学委员会第5-1工作组的组员对运用现代电导率-温度深变仪器获取盐度及温度剖面图的描述。他们的目的是提供一部操作准则，遵循准则即可获得一套可靠一致的数据。

本文各章内容依次为：传感器，传感器的校准与运转，以及对数据误差各种方法的详细讨论。最后一章提供了国际海洋考察理事会通过的供数据交换使用的准则。

五篇附录的许多专题做了深入探讨，其中包括电导计划的制订，高效低阻滤波器，数据交换编排，实际盐含量作为电导率的一个函数的算法，最后探讨了如何确定温度计冰点的校正。

FOREWORD AND ACKNOWLEDGEMENTS

SCOR Working Group 51 was formed with Terms of Reference:

- To identify problems in correcting temperature, conductivity and pressure measurements made with profiling instruments and in calculating salinity and density;
- To consider instrumental tests, calibrations and intercalibrations required before the above problems can be resolved;
- To review correction and conversion methods presently used by the major laboratories,.
- To advise on procedures for obtaining CTD data sets

SCOR Working Group 77 on Laboratory Tests Related to Basic Physical Measurements at Sea has since been established and has taken up the second term of reference. This report therefore mainly addresses the other terms of reference.

An additional source of information on the subject is the excellent series of papers presented at a symposium of the ICES Hydrography Committee in London in 1985.

The report consists mainly of edited versions of substantial written contributions made by several members of the group. Some of these are available in extended form in Unpublished Reports of their Institutes and are listed with the references. As chairman I am most grateful to them and to all members of the group for their hard work. Any errors in fact or interpretation which have arisen as a result of this editing process are to be attributed to me. I also thank Dr. Ferris Webster and the College of Marine Studies, University of Delaware for their hospitality in this last year.

The membership was J Crease (Chairman)(IOS/UK), T M Dauphinee (NRC/Canada), P L Grose (NOAA/USA), E L Lewis (IOS/Canada), N P Fofonoff (WHOI/USA), E A Plakhin (Institute of Oceanology/USSR), K Striggow (IfM Warnemunde/DDR) and W Zenk (IfM Kiel/FRG). I am also grateful to the rapporteurs of the Group: to Paul Tchernia (France) and, more lately, to Henry Charnock (U. of Southampton/UK) who assisted greatly in the final editing of the report.

James Crease

CONTENTS

	Page
1. INTRODUCTION	25
2. THE SENSORS	26
2.1 Conductivity	26
2.2 Temperature	28
3. CALIBRATION OF CTD SYSTEMS	30
3.2 An Institute's Calibration System	32
3.3 Summary	39
3.4 Conclusions	39
4. CTD OPERATIONS	39
4.1 Pre-Cruise Preparations	39
4.2 Log Books	39
4.3 Maintenance on Board	39
4.4 Special Problems in Measuring Pressure	39
4.5 Starting a CTD Cast	42
4.6 Lowering Speed	42
4.7 Recording Rate	42
4.8 Calibration &, Comparison	43
5. DATA PROCESSING	43
5.1 Introduction	43
5.2 Definition of Terms	44
5.3 Data Processing	44
5.4 Recommended Practices	55
6. GUIDELINES FOR EXCHANGE	55
6.1 Introduction	55
6.2 Data Standards	55
6.3 Format Standards	56
6.4 Series Header Information	56
6.5 Data Documentation	56
APPENDIX A: THE DESIGN OF OBSERVATIONAL PROGRAMMES	58
A.2 Senior Response	59
A.3 Sensor Time Constants & Sampling Considerations	60
A.4 Computer Simulations of CTD Observations	61
A.5 Examples Using Observational Data	63
APPENDIX B: DIGITAL LOW-PASS FILTERS	68
B.2 Running Mean Filters	69
B.3 Normal & Binomial Filters	69
B.4 Designed Filters	69
APPENDIX C: GF3 STANDARD SUBSET FOR CTDs	78
APPENDIX D: ALGORITHMS FOR PRACTICAL SALINITY COMPUTATION	89
APPENDIX E: ICE-POINT CHECKS OF THERMOMETERS	91
BIBLIOGRAPHY	91
REFERENCES	92

LIST OF FIGURES

	Page
2.1 Simplified Response of Conductivity Cell to a Step Change	26
3.1 Temperature Calibration	33
3.2 Residual Conductivities	34
3.3 Residual Pressures	34
3.4 Rosette-CTD Conductivities	36
3.5 Conductivity Differences against Pressure	36
3.6 Histograms of Conductivity Differences	37
3.7 Conductivity Differences versus Station	37
3.8 Conductivity Differences versus Pressure	38
4.1 Sample CTD Logbook	41
5.1 Frequency Responses of Selected Filters	46
5.2 Complex Frequency Response of Analogue Time Lag Operation	47
5.3 Complex Frequency Response of Analogue Lag Correction Scheme	48
5.4 Compaction of Data by Flexure Points. Error in $S < .04$ S-, $T < .03$	54
A.1 Nomograms	59
A.3 Artificial Sea Designed to Demonstrate CTD Response	61
A.4 CTD Response-example 1. dS is "(observed-true") Salinity	62
A.5 CTD Response-example 2. "Fast Sampling System	62
A.6 CTD Response-example 3. Same as ex. 2 but Optimized both for Drop Rate Sensor Separation	63
A.7 CTD Response-example 4. Effect of Velocity Variations	64
A.8 Processing in Calm Seas	65
A.9 Processing in Moderate Seas	66
A.10 Processing in Violent Conditions	67
B.1 Cosine Response for Several Running Mean Filters	68
B.2 Cosine Response for Filter #1 of 16 Weights	70
B.3 Cosine Response for Filter #2 of 15 Weights	71
B.4 Cosine Response for Filter #3 of 9 Weights	72
B.5 Cosine Response for Filter #4 of 10 Weights	73
B.6 Cosine Response for Filter #5 of 15 Weights	74
B.7 Cosine Response for Filter #6 of 31 Weights	75
B.8 Cosine Response for Filter #7 of 15 Weights	76
B.9 Cosine Response for Filter #8 of 8 Weights	77

LIST OF TABLES

1.1 Specifications	25
B.1 Weights & Responses of Some Filters	69

APPENDIXES

A: THE DESIGN OF OBSERVATIONAL PROGRAMMES	58
B: DIGITAL LOW-PASS FILTERS	68
C: GF3 STANDARD SUBSET FOR CTDs	78
D: ALGORITHMS FOR PRACTICAL SALINITY COMPUTATION	89
E: ICE-POINT CHECKS OF THERMOMETERS	91

BIBLIOGRAPHY	91
REFERENCES	92

1. INTRODUCTION

For many years measurements of salinity were made by the Knudsen titration method on samples obtained by using water bottles, such as Nansen bottles, to trap the water from a particular depth at a chosen station location. At the same time as the samples were obtained, protected and unprotected reversing mercury thermometers were operated to obtain simultaneous observations of the *in situ* temperature and of the depth (pressure) from which the sample was obtained.

During the 1950s the titration method for salinity was gradually replaced by a method involving the estimation of salinity from the electrical conductivity of seawater at a known temperature and pressure. Ship-borne salinometers were used to compare the electrical conductivity of a sample, directly or indirectly, with that of standard seawater. The methods used to obtain the samples, and to measure the temperature and depth, were unchanged.

From about 1970 the traditional 'water-catching' method of obtaining samples from discrete depths for analysis in a laboratory, at sea or ashore, was gradually replaced by the use of profiling instruments which could be lowered into and recovered from the ocean and which produced a continuous record of salinity and temperature and depth. The salinity was calculated from determination of the electrical conductivity, temperature and pressure.

Such profiling instruments are inevitably much more complicated than the sampling bottles and mercury thermometers they have largely replaced; they are lowered on electrical conductor cables instead of the simple hydrographic wire and the winches involved are bigger and more complex; the sensors are delicate and need careful calibration; advanced electronic circuitry is involved; neither operating procedures nor methods of data analysis is yet standardised.

Nevertheless such profiling instruments, CTDs, have changed our perception of the vertical structure of the ocean: temperature and salinity are now accepted to vary markedly in the vertical, leading to better understanding of horizontal stratification and interleaving of water masses, to clearer delineation of frontal structures and to an opening up of a whole new field of research into microstructure. The newly attained vertical resolution is improving our knowledge of heat and salt transfer in the ocean and has stimulated research into the physico-chemical properties of seawater as well as into the problems of instrument design and operation and into the processing, archiving and exchange of the much larger quantities of data obtained.

	Range	Accuracy	Resolution	Stability/month
Conductivity $mS.cm^{-1}$	1-65	.005	.001	.003
Temperature $^{\circ}C$	-2 to 32	0.003	0.0005	0.001
Pressure $dbar$ $10^4 Pa$	0-300	0.5	0.005	0.3
	0-650	1.0	0.01	0.7
	0-6500	6.5	0.1	6.5

Table 1.1 Specifications

This report seeks to assess present methods of using instruments of the CTD type and to identify good practice in the hope that methods used by the wide variety of observers will **converge towards the production** of data of uniformly high standard that can be conveniently and confidently archived and exchanged.

No particular instrument is singled out for discussion; a variety exists, with a range of sensor types and specifications and, others are being developed: the discussion is limited to instruments lowered on a single-core conductor wire from a nearly stationary vessel to obtain temperature and salinity measurements on a vertical scale of 1 m or larger i.e. for fine-structure rather than microstructure. A typical instrument specification is shown in table 1.1.

Chapter 2 deals with the sensors used in CTD instruments and Chapter 3 with calibration. Chapter 4, which deals with the CTD operations assumes little or no previous experience so will be of particular

interest to newcomers to the field. Chapter 5 is devoted to data processing and Chapter 6 to guidelines for data exchange. Appendix A is an extended treatment of one group's use of the techniques described in the earlier chapters. Appendix B gives the characteristics of some of the low pass filters discussed in Chapter 5. Two further appendices give the exchange formats and algorithms endorsed by the international community. Finally Appendix E describes how to check the ice-point of thermometers.

2. THE SENSORS

2.1 CONDUCTIVITY

The ability of seawater to conduct electrical current is caused by the mobility of its dissociated ions. The specific electrical conductivity C can be expressed as

$$C = N.n.e.(u_+ + u_-)$$

with N the number of ions, n valence, e elementary charge, u_+ and u_- the mobility of positive and negative ions. From this we see that the conductivity of sea water C depends on its salinity expressed through the number of dissociated ions. Pressure and temperature change the conductivity by their influence on the mobility of ions. In oceanography the conductivity unit $mS.cm^{-1}$ equivalent to $mmho.cm^{-1}$ is generally used. The conductivity of sea water under natural conditions ranges between 20 and 55 $mS.cm^{-1}$ although at certain extreme locations such as estuaries isolated from the open ocean (Eastern Baltic) or near hot brines, this range must be extended to between 1 and 60 $mS.cm^{-1}$. Conductivity changes of 0.01 $mS.cm^{-1}$ can be caused by either temperature changes of 10 mK or salinity variations of 0.01 on the practical salinity scale or by pressure variations of about 20 $dbar$. These numbers demonstrate the physical constraints within which conductivity observations have to be made to be an adequate substitute for direct salinity measurements by titration.

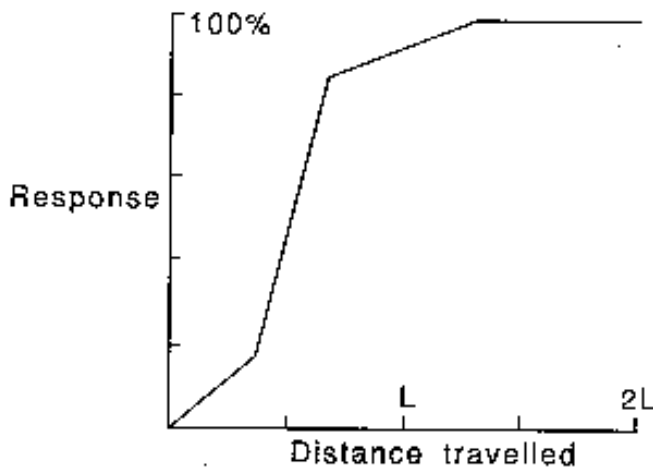

Figure 2.1 Simplified response of conductivity cell to a step change

2.1.1 Measuring Technique

In all cases the measurement of electrical conductivity is performed by the determination of the resistance of a test water column. The relationship between conductivity C and resistance R_c , (or conductance G), is given by the "cell constant k of the measuring device as $R_c = 1/G = k/C$ with $k = l/q$, where l is the length of the water column, q its cross section.

Cells to measure the electrical conductivity of sea water use two basic sensing methods: inductive and conductive.

- In the inductive sensor, the sea water is the medium linking two coils in a transformer and the losses associated with this linkage are measured to give a conductivity value.

A typical configuration is a short cylinder containing coils pierced by an axial hole of diameter 1 or 2 cm; there is no direct electrical contact between the circuit and the sea water. A crucial problem in developing an appropriate circuit is to prevent the inevitable non-linear shift of the permeability of the cores of the coils, due to pressure and temperature changes, affecting the instrument's output (Striggow and Dankert, 1985). In theory, the magnetic and electric field patterns of this sensor extend out to infinity, but in practice the conductivity measured is predominantly that of the water within the central hole. Nevertheless external bodies such as pressure cases, walls of laboratory tanks, etc. within tens of centimetres of the cell may affect its reading. This "proximity" effect makes them difficult to calibrate.

- In a conductive sensor at least two, and usually four, electrodes are in direct contact with the sea water and these are typically contained within a glass or ceramic tube having a length of order centimetres to tens of centimetres and 0.5 to 1 cm diameter so as to provide a suitably high electrical impedance (100 ohm) to the circuit. For example, the Guildline Mk IV CTD conductivity cell consists of a pyrex glass tube of internal diameter about 6 mm and length 14 cm, having four side arms containing the electrodes. The proximity effect is far less marked than for inductive sensors.

The time constants of these cells are primarily affected by the time taken for water to be exchanged, that is, they are "flushing" time constants, any delays due to the electrical circuitry usually being insignificant in comparison. The typical shape of a conductivity versus time curve for either of these conductivity cells responding to a sudden change in water properties is shown in Figure 2.1. The response reaches 63% when 0.55 of the cell is immersed in the new water. The initial slow rise corresponds to the change approaching the cell, the steep slope to a change of water mass within the cell or between the electrodes, and the reduction to lower slope as the change moves away. In both

	$\alpha/^\circ C$	$\beta/dbar$
<i>Quartz</i>	5.1×10^{-7}	9.0×10^{-8}
<i>Pyrex</i>	3.2×10^{-6}	1.0×10^{-7}
<i>Alumina</i>	6.5×10^{-6}	1.5×10^{-1}

Table 2.1

cases there is a long tail as it approaches the final value due to the boundary layer of "old" water remaining near the wall until flushing is complete. The proximity effect causes inductive sensors to have an effective length considerably greater than the physical length, more than is the case for conductive sensors.

2.1.2 Pressure and temperature dependence

In all cases conductivity cells separate a certain test volume electrically from their environment. In general the test volume is measured within a tube whose cell constant k varies under hydrostatic pressure and with thermal expansion. The relative change of k can be expressed as

$$\Delta k / k = -\alpha.(T - T_o) + \beta.(P - P_o)$$

with T_o , P_o the temperature and pressure at a reference level, α the coefficient of linear expansion and β the coefficient of linear compressibility (1/3 of the volume compressibility).

Table 2.1 gives (α and β for some commonly used materials in conductivity cells. The equation to correct the conductivity is

$$C = (k / Rc). (1 - \alpha. (T - T_o) + \beta. (P - P_o))$$

The reference temperature T_o and pressure P_o will be given by the calibration conditions. Often they will coincide with the laboratory room temperature and atmospheric pressure. In special cases it is convenient to use T_o and P_o for deep ocean conditions as Fofonoff et al (1974) did for the Mid Ocean

Dynamics Experiment ($T_o = 2.8^\circ\text{C}$ and $P_o = 3000$ dbar). Fofonoff et al (1974) and Ginzkey (1977) have shown that cell deformations under high pressures (5000 dbar) and large temperature changes (20°C) cause the conductivity to be underestimated by as much as 0.012 mS.cm^{-1} , yielding a salinity error of 0.015 if not corrected for by the above procedure.

2.1.3 Practical use and maintenance of conductivity cells

As described above all conductivity cells are sensitive to variation in cross section during profiling. Such obstructions can be caused by drifting objects, salt crystals or biological fouling. In addition electrode cells have to be protected against hydrocarbon contamination and calcium carbonate covering. In general, contaminations will cause lower conductivity indications. Cleaning procedures with non-ionic detergents and micro-organism growth preventing solution have been described in the literature (Pederson and Gregg, 1979). Occasional ultrasonic bath cleaning followed by flushing seems to be a useful method for conductivity cells. However, in many cases a baby-bottle brush will be sufficient as a standard cleaning tool. Fouling with salt crystals may be prevented by filling the cell with distilled water between operations.

2.2 TEMPERATURE

2.2.1 Measuring techniques

Practically all temperature sensors used in CTD instruments use the variation with temperature of the resistance of a length of platinum, or occasionally copper, wire. They have proved to be very stable and so superior to semiconductors such as thermistors. They are more accurate than mercury-in-glass thermometers so comparisons between them are only useful as an indication of gross malfunction. The pressure sensitivity of a typical resistance thermometer is only about $0.04^\circ\text{C}/\text{km}$ but compensation may be unreliable due to hysteresis so the elements are normally enveloped in a pressure resistant casing so that corrections are not required. This necessarily involves an increased thermal lag so exposed elements are sometimes used if rapid (millisecond) response is needed. These can be resistance thermometers, thermocouples or thermistors for which, as they do not require high absolute accuracy, adequate corrections can be made from the pressure measurements; they are of more interest for microstructure than fine structure, so peripheral to the main subject of this report. Some commercial CTD instruments, however, use a combination of a relatively slow but accurate resistance thermometer with a fast response thermistor to record rapid fluctuations only.

Several different types of electronic circuits are used in conjunction with the resistance elements the four most common ones being:

- Frequency modulation of an oscillator having the thermometer as an element of its frequency control circuit (Brown, 1968). This type of circuit is widely used for thermistors and lower accuracy systems and has the advantage that the readout is a simple count of the oscillations over a fixed time period, or of a carrier frequency over a fixed number of cycles of the basic frequency.
- A two-phase circuit (Kroebel, 1980) with 90° phase angle between a bridge arm made up of the thermometer and reference resistor in series and a ratio arm with + and - reference taps, so that the phase shift of the reference voltages (vs. the common point of the bridge arm) due to temperature changes are in opposite directions. The total phase shift is measured by counting a high multiple of the excitation frequency between zero crossings.
- Subtraction of the voltages across a thermometer and a series reference resistor by capacitive transfer to give a square wave difference voltage which is amplified with precise gain and demodulated to give an output proportional to temperature (Dauphinee, 1972).
- A transformer coupled AC thermometer bridge with inductive ratio arms and negative feedback with a linearising network to give an output voltage proportional to the deviation from the balance temperature (Brown, 1974). The deviation is read with a 16 bit inductive-ratio AC A/D converter.

2.2.2 Sensor performance at sea

All these circuits are capable of impressively high accuracy under laboratory conditions - the errors result from the great difference between laboratory and field conditions rather than the primary calibration. These include:

Electrical leakage

Control of leakage is largely a matter of attention to detail in ensuring a permanent effective conduction barrier across every potential leakage path. In a really dry environment a few tenths of a millimetre of clean insulating surface is sufficient to ensure electrical isolation at the voltage levels found in most CTD probe circuits. Even a small amount of salt contamination can be tolerated, since dry salts are insulators as well. Unfortunately a truly dry environment is almost impossible to maintain if the probe has to be opened at sea and the least amount of moisture will tend to make conductive any salt film left by the fingers in handling or by settling of airborne droplets. Even oil films or solvent residues can be slightly conductive at high humidities. So rigid attention to cleanliness and moisture control in the probe is essential. The interior of the probe must be kept free of salt water and at low humidity, with packs of drying agent wherever appropriate. The probe should preferably not be opened at sea or, if necessary for maintenance, opened under dry conditions if possible. The points of maximum risk are of course the sensor leads and low-level sections of the circuit, particularly where they lie close to power and output lines, for instance at the IC pins. Electrical leakage in external plug connections and connecting cables can be controlled by careful attention to drying before assembly, by filling all voids into which water might be forced under pressure with an incompressible insulator such as oil or grease, and by arranging for pressure equalisation, or better still, some positive internal pressure at the mating surfaces in contact with seawater. It is very important to remove all traces of salt and moisture from the plug connections, in particular from the blind holes in the female receptacles, and to apply enough grease to fill all voids and prevent leakage across the mating surfaces before joining the plug. Otherwise leakage across the surfaces between pins will cause trouble. The open-hole design of some plugs gives good leakage protection, but the forces involved in separating these plugs have in our experience led to many plug failures through breakage of conductors.

Temperature variations

Probe temperature can affect the resistances of leads and circuit components, including gain control resistors and trimming potentiometers, and particularly solid state components. It can also affect thermal emfs and zero offset in dc parts of the circuit. Aside from the sensor leads, the resistors of the basic measuring bridge are likely to be most critical. Power and space requirements usually prevent thermostating but low-temperature-coefficient t , stable resistors are now available which with selection allow stable balances to 1 mK if all resistors are at the same temperature. Potentiometric circuits allow use of relatively simple temperature compensation networks.

Lead lengths and positioning of sensors

AC circuits, particularly those operating at high frequency, usually require some form, of phase balancing which, if accurately done, eliminates the frequency error. However, serious errors can occur when the sensor is moved with respect to the probe body or extension leads are used if the original phase balance no longer applies or the automatic phase balance has exceeded its range. Any circuit that doesn't give a true potentiometric balance is likely to be susceptible to changes in lead resistance, with significant changes to the mK level being milliohms or less. Consequently, major changes from the manufacturer's configuration are likely to require complete recalibration or careful adjustment of the lead resistances. Any added resistances in the leads must be small enough that variations in them due to temperature or mechanical stress do not result in significant errors.

Mechanical effects

Certain types of mechanical stress can have a major and serious effect on the temperature sensor and the precision resistors in particular. Stability depends on the resistive elements being maintained in the same shape and state of anneal, at least between calibrations. In general any deformation that exceeds the elastic limit at any point will result in a permanent change of calibration, including the deformations that go with vibration or with exposure to extremes of temperature or major shock. Strong variation is

particularly dangerous because of the long periods over which it is likely to occur. In addition to a progressive change of calibration of the sensor there is a possibility of fatigue cracking or weld separation at joints or bend points with subsequent flooding when exposed to high pressures. The following general rules should be followed at all times if a stable calibration is to be maintained

- Protect the probe against extremes of temperature, and allow only slow changes beyond the normal range. Only specially adapted probes should be exposed to winter arctic temperatures or to high altitude air travel in an unheated cargo bay.
- Make sure that the thermometer is mounted so as to avoid striking any solid object, or ensure sufficient care that it doesn't do so. A **bent thermometer will probably** still work but its calibration may be changed by many millidegrees. The stainless steel helix types can take much more distortion than most others.
- Isolate the probe from ship's vibration when on deck or in storage.
- Protect the probe from violent shocks such as striking the side of the ship, and from rough handling in shipment. A damped-spring type mechanism is preferable for shipping and on-board storage. The protective cage should give a little if it strikes the ship to reduce the probe accelerations.
- Avoid icing of the sensors to avoid stress induced calibration changes or damage. The results will be useless anyway until the ice is completely melted.
- Flush the thermometer with fresh water after the cast and whenever it has been splashed with seawater. In particular, don't allow it to dry with seawater on it or stand partially immersed in unstirred salt water. Electrolytic action at the air-water interfaces causes pit corrosion which, given time, can penetrate right through the sheath.

Heat dissipation

Many circuits dissipate enough power to heat the water near the probe surface significantly at low flow rates. It is important that this heated water does not heat the sensors. The temperature and conductivity sensors themselves are capable of changing the temperature of the small volume of water immediately around them by a few millidegrees when there is low flow in the field or laboratory calibration.

3. CALIBRATION OF CTD SYSTEMS

3.1

The laboratory calibration of a CTD system presents a number of special problems. This is because one needs to simulate the combination of a set of conditions not actually realisable in the laboratory. The calibration must be done in such a way that the effects of the combined errors for any particular combination of prehistory of T , C , and P that may occur in the real ocean will lead to an acceptably small error in the determination of these parameters as well as in S . Consequently the thermometer should not be treated as a completely independent sensor; in many cases a small error in T can be tolerated as long as the T and C readings can be correlated to give an accurate value for S .

Equally one cannot treat the T , C , and P calibrations independently since the easiest way to determine the conductivity ratio

$$C_{s,t,0} / C_{32,15,0} = R_{t,r_1}$$

of the water in the test tank is by calculation, using a standard thermometer for temperature and a laboratory salinometer for salinity, along with the Practical Salinity Scale 1978 algorithm (UNESCO, 1981 and Appendix 4) There is no point in carrying out calibrations outside the combination of T , S , and P found in the real ocean or to an accuracy greater than the combination justifies. For instance only a

narrow range of S and T around $S=35$ and $T=0^\circ C$ is significant at very high pressures, except in enclosed seas, while the normal variation of estuarine salt makes real precision unnecessary.

An additional complication is that the sensors are attached to a probe of frequently inconvenient shape that in many cases cannot be separated from it without serious uncertainties in the calibrations. The result has been that nearly all CTD casts have given results that are far less accurate than the theoretical potential of the system over at least part of the range, and almost always through the thermocline. Recovering even part of the lost accuracy by allowances for previous observations, time constants, etc., often involves computer programming and calibration time out of all proportion to the benefits achieved. But there can be few systems whose accuracy cannot be improved by calibration, and certainly none so reliable that routine checks against gross calibration changes can be safely eliminated.

The crucial objective of a CTD calibration is to establish a relationship between the readings of the various sensors and the water parameters they purport to measure, as they exist in-situ. Calibrations usually give numbers corresponding to static conditions when all the relevant parameters are held constant and can be measured most accurately. The heat capacity and bulk of the probe make it very difficult to determine the deviations from static behaviour that occur in periods of rapid change. Unfortunately those deviations are very important since one must be able to correct for rate-dependent errors, either by matching time constants so that simultaneously determined readings correspond to the same point in ocean space, or by choosing reading times for the different sensors on the basis of known time constants, accomplish the same purpose. At the same time we must account to the required accuracy for any long term, history dependent changes.

The most obvious effect will normally be on the lags of the various sensors, causing them to read a time-weighted average of the true value, which smears out the shape of the variations. The thermometer usually has the longest time constant while the conductivity cell is limited only by the rate at which the old water can be replaced by new water in it, the cell itself having no significant intrinsic time constant. The pressure transducer usually gives a nearly instantaneous response but is the most likely sensor to give trouble with sensitivity or zero shifts and hysteresis. Some matching of sensor responses can be done either electronically or by computation, but precise matching by this means is time consuming and usually dependent on drop rate through the water.

The length of time between switching on the power in a uniform environment and final settling to the true value is easier to determine. It can take a considerable time, even minutes, as the various components self-heat to operating temperatures and the conductivity electrodes stabilise. The effect of thermal shock on the system can also be determined fairly easily if the T and S sensors can be separated from the probe or substituted with appropriate resistances while the probe is transferred from room temperature to an ice-bath or vice-versa. An approximate correction for the transients caused by the thermocline and first insertion into the water can then be made on the basis of the rise and decay time constants of the transients.

Calibration under static conditions is usually carried out in a temperature controlled, stirred bath at a number of salinities and normal surface pressures. A description of the methods adopted by one major user is given later in this chapter.

Calibration under pressure is much more difficult, particularly the conductivity measurement, because of problems with water circulation and thermal contact inside the pressure housing and inability to assure that there are no bubbles in the cell. Fortunately, most thermometers have a pressure isolation jacket to protect the element and should give the same calibration whether under pressure or not. An exposed thermometer that is truly strain-free will change reversibly by about $0.04^\circ C/km$ depth (Bridgeman, 1916) with possibly a small hysteresis to the recovery after pressure (Kroebel, 1980). A conductivity cell is normally in hydrostatic equilibrium with its surroundings and will change reading according to the pressure coefficient of conductivity of seawater (see PSS 1978 equations) and slightly because the compression of the cell changes its cell constant by $1/3$ of the bulk compressibility, a number easily found for most cell materials in the published literature.

Because of the problems of performing pressure calibrations in all but a fully equipped standards laboratory the usual practice has been to carry out routine T,S calibrations to establish performance of

the equipment at surface pressure and then assume that the sensors are behaving according to plan under pressure. Any slight deviation from theoretical is then corrected for in the adjustment for pressure sensor error that is normally made on the basis of bottle samples taken at the same time as the in-situ profiles are taken.

Even if there is insufficient time, or if the necessary equipment for a full calibration isn't available, there are still a few checks that can be made to verify that a CTD is giving reasonable answers. Temperature is one of the easiest of these, because the most likely error to occur is a shift of the whole scale as a result of damage to the thermometer or a change of a resistor in the measuring circuit. The easiest way to detect such an error is to take an ice point on the thermometer. Appendix E gives a description of how to prepare a reproducible ice bath using the simplest of equipment. Once the bath is prepared, the thermometer and any other part of the probe that will go into the ice should be washed carefully and rinsed with clear water (distilled or de-ionised) to prevent contamination. The thermometer is inserted in the icewater slush, and the reading taken as soon as equilibrium is reached, then moved in the ice and read again. Once the ice point has been checked the sensitivity can be checked quite accurately by placing the thermometer, and probe if necessary, in a stirred, insulated tank at a temperature near the top of the range of a good reversing thermometer, which has also had its ice point checked, and which is used to measure the temperature of the bath. The two point calibration gives a highly accurate location of the zero, and about a 1 in a 1000 check of the slope, sufficient for a few millidegrees accuracy over the most crucial lower end of the scale.

For the greatest precision the triple points of a number of substances can be used to calibrate a temperature transfer standard to millidegree accuracy at points over the entire oceanographic range. Examples of these substances and their triple points are water at 0.0100°C, Phenoxybenzene at 28.8686°C and Ethylene Carbonate at 36.3226°C. A second useful check that should be carried out before every cruise, and occasionally during the cruise if possible, is a comparison of the salinities calculated from the CTD readings when in the stirred bath with salinometer samples taken from the bath. If the bath can be maintained near the ice point (or other triple point), so much the better since the thermometer will be more accurate there and any error can be attributed to the conductivity measurement. Measurement at two salinities near the ice point can check the salinity circuit which can then be used with the salinometer at higher temperatures to check the thermometer more accurately.

3.2 AN INSTITUTE'S CALIBRATION SYSTEM

In this section we bring together the calibration techniques for each of the CTD sensors as described by one major user (WHOI). In other chapters reference will be found to variants on the methods adopted here. These reflect the effect of availability of different instruments and resources.

The discussion refers to three NBIS CTD systems in which the fast response thermistor input to the platinum thermometer interface, incorporated to provide high frequency response, has either been dispensed with or is digitised as a separate data channel on one CTD (Millard, Toole and Swartz, 1980). The three CTDs have a temperature compensation collar on the pressure transducer and measure conductivity with the 3-centimetre general purpose cell. The larger cell and the use of the platinum thermometer without thermistors reflects the present feeling that high resolution microstructure work demands specialised instrumentation.

3.2.1 Laboratory Calibration

The CTD temperature, conductivity, and pressure sensors are calibrated against transfer standards prior to and after each cruise. Calibration adjustments are not made to the CTD electronics except when sensors are replaced. It is easier to monitor the performance of the instrument if such adjustments are made only rarely: only the laboratory calibrations are relied on to adjust the calibration coefficients of temperature and pressure. However the main use of the laboratory calibration of conductivity is to check the linearity of the sensor: the conductivity cell drifts sufficiently to require field calibration to obtain salinities to better than .01.

CTD temperature and conductivity laboratory calibrations are made against an NBIS calibration unit transfer standard with the CTD system fully immersed in a temperature regulated bath at salinity

approximately 35. Figure 3.1 shows CTD temperature correction curves (calibration unit minus uncorrected CTD temperature) for two of the CTDs versus temperature over an 18 month period for two CTDs. One drifted 6 millidegrees colder while the other drifted 8 millidegrees warmer in 14 months. These are unacceptable errors in deep water if left uncorrected. The parabolic curvature of the calibration curves is removed by fitting the temperature to a second order polynomial. The accuracy of the laboratory temperature calibration is better than .003°C over the range 0 to 30°C with a greater uncertainty away from 0°C if only the triple point of water is used as a reference. The uncertainty in the CTD temperature accuracy in the field must include the sensor drift with time of about .0005°C per month. The reversing thermometers used to check the CTD temperature are usually not accurate enough to recalibrate the CTD in the field although small range (-2 to 2°C) thermometers can with care be calibrated to .003°C so as to provide a useful field check on the CTDs whose temperature sensor is suspected of temperature jumps in the field of this order, especially when transfer standards described above are not available. Replacement of reversing thermometer checks by redundant electrical thermometers is increasingly preferred. This practice saves all the time lost on station waiting for the reversing thermometers to equilibrate.

The calibration unit conductivity residuals from a linear fit with CTD conductivity are plotted in Figure 3.2 for the two CTDs over the same time period as the temperature calibration in Figure 3.1. The calibration unit conductivity sensor can only be immersed 6 inches while the CTD conductivity sensor is normally 30 inches below the surface. Vertical conductivity gradient corrections as large as .003 $mS.cm^{-1}$ are applied to the calibration unit conductivity. Figure 3.2 shows that the conductivity of both CTD 8 and 9 are linear to within .0015 $mS.cm^{-1}$ over the range 29 to 59 $mS.cm^{-1}$.

The CTD pressure calibration is made against a deadweight tester with corrections described in Fofonoff et al (1974). Figure 3.3 shows a plot of the residuals of a least squares linear fit between CTD and dead weight pressures over increasing and decreasing values. CTD 9 shows the largest deviations from linearity while CTD 7 shows the largest hysteresis between increasing and decreasing pressure. The CTD pressure transducer is calibrated with a third order polynomial fitted separately to the increasing and decreasing pressure values.

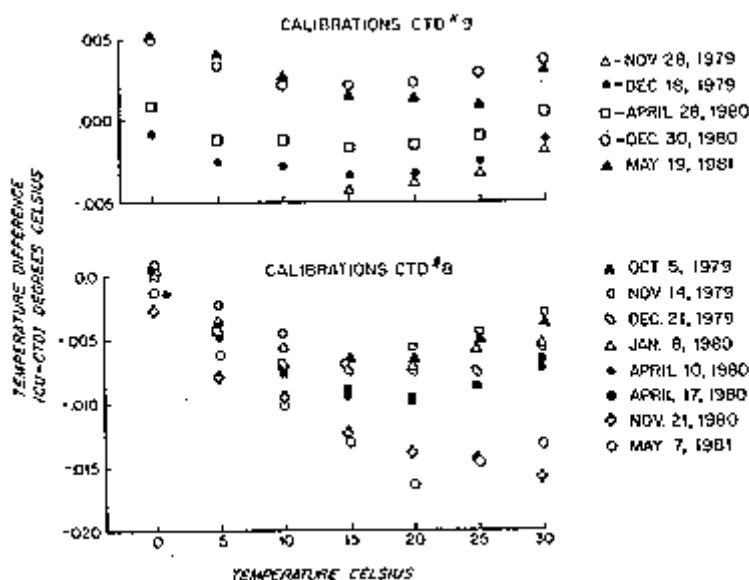

Figure 3.1 Temperature calibration curves (calibration unit - uncorrected CTD) over a period of a year for CTD9 and CTD 8

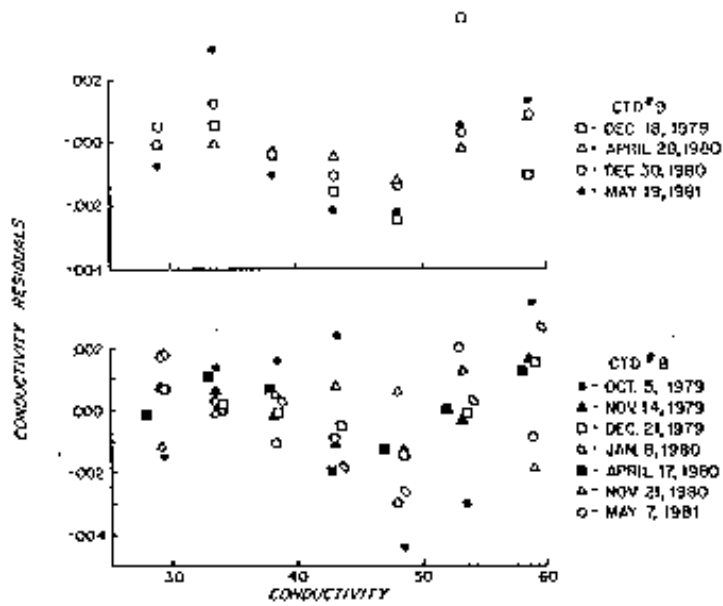

Figure 3.2 The residuals from a linear fit of the NBIS calibration unit conductivity to CTD conductivities

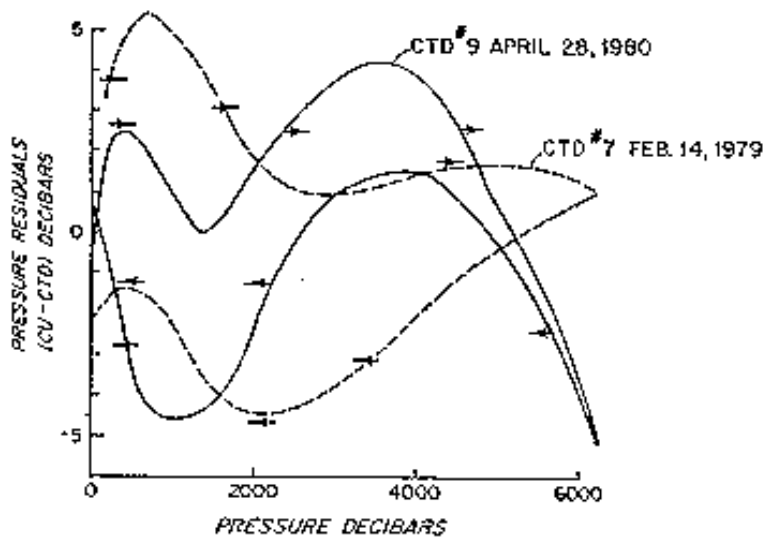

Figure 3.3 The residual pressures between the corrected deadweight tester and a linear fit to the increasing \rightarrow and decreasing \leftarrow CTD pressure values

3.2.2 Field comparisons with sample bottles

Water samples are normally collected on each CTD station using a 12 or 24 bottle rosette sampler mounted 1 meter above the CTD sensors. The Niskin bottles are closed during the up cast of the station while the CTD is stopped. The salinity samples are analysed on a salinometer in which a precision of .001 is achievable under careful laboratory conditions (Mantyla, 1980). The poor temperature stability of the ship's laboratory at sea usually degrades this precision. To evaluate the CTD systems' salinity precision, Rosette salinity observations have been compared with simultaneous CTD observations from 3 NBIS CTDs. The water samples were collected over a temperature range of 0 to 28°C and a pressure range of up to 5600 decibars.

3.2.3 Conductivity calibration

To compare conductivity and salinity an algorithm to convert one to the other is required along with a decision about which variable should be compared. Since the CTD conductivity sensor is to be calibrated, Rosette salinity is inverted to an in-situ conductivity using the CTD temperature and pressure. The 1978 Practical Salinity Scale algorithm was used for conversion between salinity and conductivity (see Appendix 4). An error of $.001 \text{ mS.cm}^{-1}$ in-situ Rosette conductivity results from the following individual errors.

- Salinometer salinity error = .001
- CTD pressure error = 2.5 dbar
- CTD temperature error = .001°C

The CTD conductivity is corrected for the sensor deformation with temperature and pressure as described in Chapter 2.

$$C(CTD) = Ck(1 - \alpha T + \beta P)$$

The conductivity cell factor k is chosen to minimise the least square differences between CTD and Rosette conductivities over a group of stations (see Appendix of Fofonoff and Bryden 1975 for discussion). Conductivity differences are defined as

$$\delta c = C(Ros) - C(CTD)$$

$$\text{and } C(Ros) = SAL78(S(Ros), T, P, I),$$

and $C(Ros)$ is the Rosette conductivity, $S(ROS)$ is Rosette salinity. SAL78 is the 1978 Practical Salinity scale algorithm (appendix 4). P and T are CTD pressure and temperature. The conductivity differences shown in Figures 3.4 through 3.8 have been edited to remove spurious observations with differences exceeding $.013 \text{ mS.cm}^{-1}$, unless otherwise indicated. This editing criterion typically removes between 2 and 4 percent of the comparisons of a cruise.

3.2.4 Field conductivity comparisons

Atlantis 11 cruise 107 from May to October 1980 provided 3600 water sample/CTD comparisons with CTDs collected over a 5 month interval using a 24 bottle Rosette sampler. These conductivity comparisons are summarised by station in Figure 3.4 a-c, corresponding to cruise legs 8, 10 and 11 respectively. The CTD conductivity of each leg has been adjusted by a single cell factor annotated on the figures. Notice the value of cell factor shifts between leg 8 and 10 by an amount equivalent to .01 (Figure 3.4) in the expected sense for gradual coating of the cell. The station averaged conductivity difference is plotted as an indication of when further refinements of the conductivity calibration might be necessary. Average conductivity differences of $.005 \text{ mS.cm}^{-1}$ are apparent within each leg and are usually associated with the CTD hitting bottom (indicated with an arrow on the figure).

A useful guide as to when the average conductivity difference of any individual station is sufficiently different from the average of the station group is the student-t test. Each leg has a mean conductivity difference of zero. The 95% confidence limit for a typical group of 1000 observations with a standard

CTD hit bottom on stations 111 and 112. One should be careful not automatically to interpret a station averaged conductivity difference outside the 95 percent limits as a CTD sensor shift since the Autosal salinometer measurement uncertainty is also reflected in the difference. Sometimes it is helpful to check the internal consistency of the Rosette and CTD salinity separately across questionable station groups using temperature-salinity diagrams to resolve shifts.

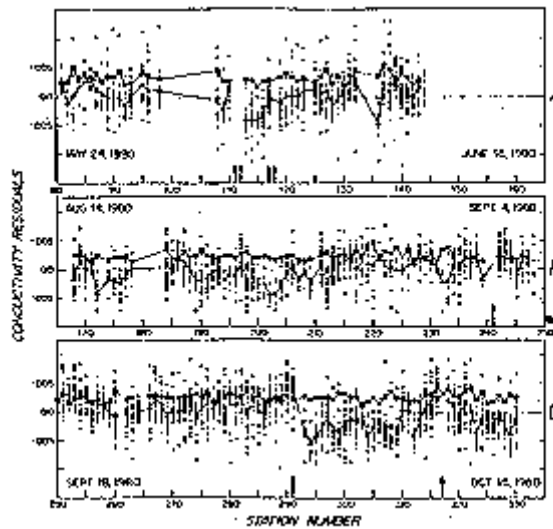

Figure 3.4 3500 conductivity differences (in-situ Rosette - CTD) versus station on Atlantis II Cruise 107. Figures a, b, and c are three separate legs, the conductivity slope of each leg is fitted separately. The symbols for each station are: \circ - individual differences L - average difference of station F1 - standard deviation of differences within a station.

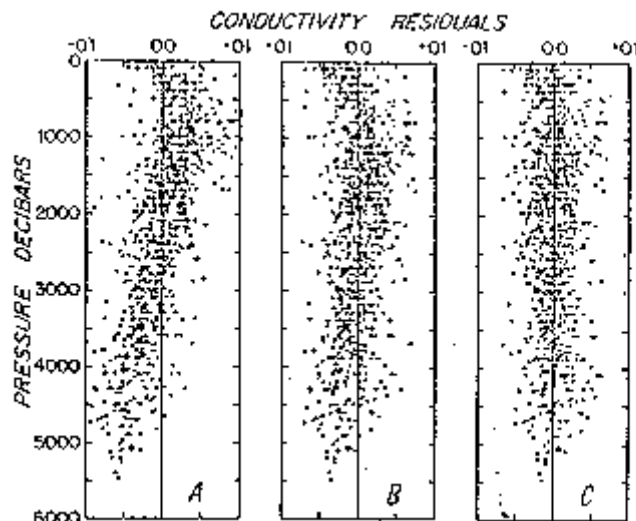

Figure 3.5 Conductivity differences versus pressure for stations 250 through 290 in Fig. 3.4c. In a) SAL69 is used with the increasing linear pressure calibration for CTD 8. b) uses SAL78 and linear increasing pressure calibration. In c) SAL78 is used together with the proper decreasing pressure calibration

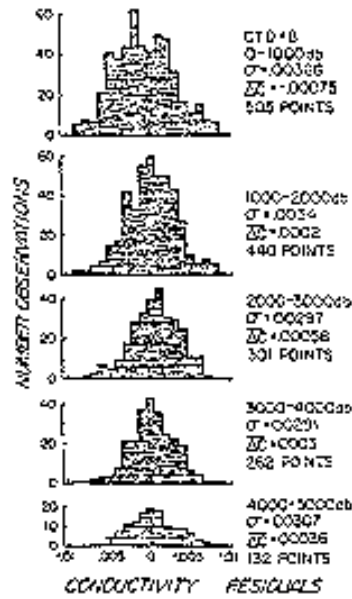

Figure 3.6: Histograms of conductivity differences in 1000 decibar intervals for stations 250 through 331 in Figure 3.4c. Note the decrease in the standard deviation of the differences at depth where vertical gradients are weaker

The old WHOI conductivity to salinity algorithm (Fofonoff et al, 1974) has been found to leave conductivity errors in the vertical as shown in Figure 3.5. Part of this error was the result of CTD pressure hysteresis between down and up casts, as comparing Figure 3.5b and c show. Figure 3.5b shows the effect of applying the 1978 salinity scale (SAL78) but vertical conductivity errors are still apparent and are associated with using the down pressure calibration. Figure 3.5c clearly demonstrates this with the up pressure calibration. The conductivity differences shown in Figure 3.5a-c are from stations 250 through 290 in Figure 3.4c. These stations have a vertical temperature range of 11 to 03°C. The scatter of the conductivity differences are found to decrease with increasing pressure as can be seen in the histograms in Figure 3.6. The histograms of conductivity differences are grouped in 1000 decibar intervals in the vertical between the surface and 5000 decibars. The fine structure in the higher vertical gradient upper 1000 decibars contributes to the larger standard deviation.

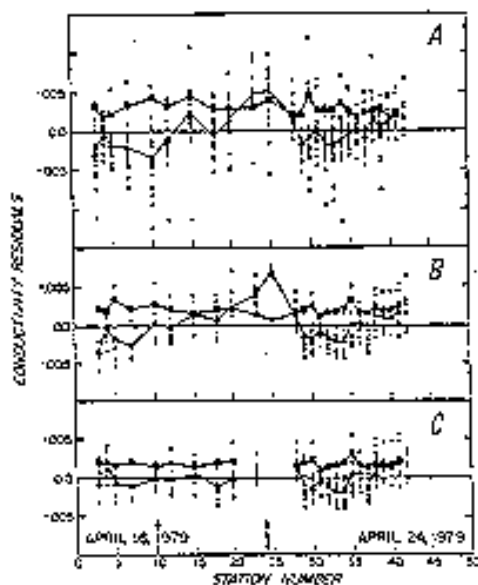

Figure 3.7 Conductivity differences versus station for CTD 7; a) all pressure levels, b) for 0 to 2000 decibars and c) for 2000 to 6000 decibars

The conductivity difference variation with station has been examined for CTD 7 on a three week cruise in the tropical Indian Ocean. Figure 3.7a-c shows a linear drift of the conductivity sensor between stations 3 and 25. The sense of the drift is again of the conductivity sensor between stations 3 and 25.

The sense of the drift is again consistent with something coating the interior of the sensor. The CTD hit the bottom on stations 10 and 24 as noted on the plot. The conductivity sensor behaved erratically on station 25 and was cleaned in 0.1 Normal HCl prior to station 28. The conductivity cell appears to continue to clean itself until station 30. Figure 3.7b-c show the conductivity differences broken up into 0 to 2000 decibars (Figure 3.7b) and 2000 to bottom intervals (Figure 3.7c). The standard deviation of the conductivity differences (+) is smaller at depth as the histograms in Figure 3.6 suggest. Also the station to station variation of the mean conductivity difference is also better behaved. Typically the conductivity slope is determined from the deeper observations as shown in Figure 3.7c, not only because the conductivity differences variance is smaller but also to minimise any systematic errors in salinity in the part of water column where the salinity signal between stations is usually smallest.

The range of the conductivity variations for CTD 7 between stations seen in Figure 3.7 is the same 0.005 mS.cm^{-1} as found for CTD 8 in Figure 3.4. Finally the precision of the vertical calibration of the CTD system is checked across CTDs 8, 7 and 9 in Figure 3.8a-c respectively. Figure 3.8a shows a systematic error between top and bottom of $.002 \text{ mS.cm}^{-1}$ part of which is consistent with the upper 700 decibar salinity gradient of $.0025/\text{decibar}$ and the 1 meter Rosette-CM separation. Note that the 1978 Practical Salinity Scale algorithm is only accurate to $.0015$ across the oceanographic range. The systematic variations show no pattern across the 3 CTDs. The vertical temperature range over which the 3 comparisons were made are approximately 25 to 05°C . The vertical conductivity variations are slightly greater than expected from the SAL78 algorithm.

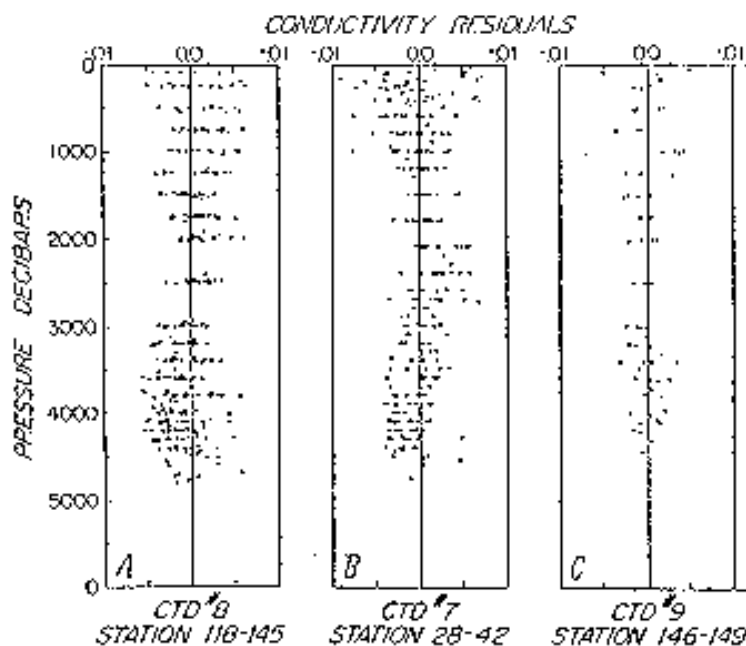

Figure 3.8 Conductivity differences plotted versus pressure for three CTD systems. (a) is for CTD 8 stations 118-145 of Figure 3.4a. (b) is for CTD 7 stations 28-42 shown in Figure e 3,7a. (c) shows four stations using CTD 9.

3.3 SUMMARY

The 1978 Practical Salinity Scale gives a significant improvement in the vertical precision of salinity obtained with the WHOI/Brown CTD System compared with the previous WHOI Salinity algorithm described by Fofonoff, et al (1974). The conductivity sensor must be continually checked at sea in order to obtain salinities more accurate than .012. Also efforts to transfer a conductivity and temperature substandard to the CTD sensors in the field should be explored. The conductivity cell expansion coefficients (α and β) published in Fofonoff, et al (1974) seem to produce well calibrated data in the vertical. The correction of the CTD pressure for down/up hysteresis is important, particularly for the calculation of salinity from the CTD.

3.4 CONCLUSIONS

In ocean zones where conditions are relatively uniform and changing slowly with depth, and with appropriate corrections, water temperatures can be determined probably to a few millidegrees and salinities to the corresponding few parts per million of salt, with resolution over short distances to possibly a millidegree and .001.

4. CTD OPERATIONS

Different groups evolve their own standards of good operating practice, some of which will be particular to the type of instrument used. In this section we cover some basic points which may seem trivial but will assist inexperienced users; several aspects will be taken up in more detail.

4.1 PRE-CRUISE PREPARATIONS

A thorough test of the complete equipment (including recording facilities) should be made prior to the cruise; it is best done before casting off! Take great care in transporting the unit from laboratory to ship. Good shock resistant transport cases are desirable. Remember the disks, tapes, sample bottles, rosette, Niskin bottles, thermometers and their calibrations, manuals and all the other items of equipment needed to deal with system operations and possible system failure in adverse as well as perfect conditions.

4.2 LOG BOOKS

A typical CTD log is shown in Figure 4.1 but the specific data required in the log is often the bare minimum. These notes can contain a lot of errors after a hard nights work. At the beginning of the cruise a precise procedure for carrying out a CTD station should be developed, discussed, put down in writing and strictly kept to by the team. It is preferable to augment it by text notes. Therefore, enthusiastic use of a "special events" section is recommended, especially including for example such items as ship manoeuvres on station, error conditions in the system, heavy rain etc. It is especially important to note when there is a change in CTD sensors in the equipment in use.

4.3 MAINTENANCE ON BOARD

The CTD should be protected against strong heating due to exposure to the sun or other causes. Pour fresh water over the instrument after use. Keep a sound velocity sensor in a bucket of fresh water or at least put a plastic bag around it. If an oxygen sensor is fitted it should not be allowed to dry out between casts. Proceed similarly with optical sensors and protect them against dirt (special care is needed in port). After a long period of use or after a period when the instrument has not been operated the electrode arrays of conductivity sensors should be cleared using a suitable brush and a lot of water.

4.4 SPECIAL PROBLEMS IN MEASURING, PRESSURE

Pressure measurements are affected by a drift of the zero and by hysteresis and by temperature changes. These properties are worst with wide range sensors (6000 dbar).

CTD STATION LOG

Ship & Cruise	Deck	Crewmember Position	Node
Ship No.			
Station (N-M-D)			
Nominal Depth			

Instr No					

On Deck Instr				

Raw CTD Data (msec Units)				Computed CTD Data (msec Units)					Sample No.			WS Data		WS Data		
NEG YrC	HIGH PTRES	FNCS TEMP	COND	O ₂ CURR	TEMP	FNCS TEMP	TEMP	COND	SALT	POT TEMP						

COMMENTS

Figure 4.1 Sample CTD Logbook

4.4.1 Zero offset

Each profile should be corrected individually. Therefore the reading at atmospheric pressure should be noted in the log book. As the sensor is sometimes temperature sensitive temperature should also be recorded at this time. A record of sufficient length (allowing for some averaging) while the CTD is still on deck will help later with corrections. If the record in air is not routinely available, this will lead to difficulty in processing data.

4.4.2 Hysteresis

The actual reading with the instrument at constant true pressure depends on the prior history of the sensor. Lowering and hoisting do not yield comparable profiles. One deep station within a series of shallow casts, may lead to an offset of the pressure reading.

4.4.3 Temperature

The pressure sensors are often temperature sensitive. In strong near surface thermoclines this can lead to different pressure readings on lowering and hoisting.

4.5 STARTING A CTD CAST

- Leave the CTD in the sea for a couple of minutes prior to starting the measurements if it has been heated up or if the sea~ air temperature difference is large. If necessary, hoist the CTD briefly above the surface to read the pressure offset.
- If the near-surface zone is of interest, it is best to start recording while the CTD is still situated above the sea surface. However, this is recommended only for calm conditions. In rough sea states bubbles due to breaking waves may lead to problems of conductivity measurement. As the ocean is rather well-mixed under such conditions, it is often sufficient to start the profile at the safer depth of a few metres. Alternatively, stabilise the instrument a few metres down, bring it up to the surface briefly and then continue with the down cast. Avoid any plume of sewage or engine-room discharge!

4.6 LOWERING SPEED

In general there is a mismatch of the time constants of the different sensors of a CTD. This can be more easily corrected if the CTD is not lowered too quickly, so as to ensure a sufficiently high data recording rate (see Chapter 5 and Appendix A). However, too small lowering speeds may degrade the data: the flushing rate of the conductivity sensor may become rather small. In addition the ship's movement is felt strongly if the CTD is lowered slowly. Reversal of the instrument velocity (leading to loopings in the analogue trace) should be avoided under all circumstances. Some CTDs can, through their configuration, yield rather low quality up profiles. Note too that the time constants of the sensors possibly depend on the lowering speed and direction. Therefore it is advisable:

- to choose a constant lowering speed for a series of casts;
- to select lowering speeds of 30 to 100 cm/s. Choose the higher values at higher sea states, bearing in mind that the freefall velocity of the instrument package yields an upper limit to the range of possible lowering speeds and that greater speeds can lead to disaster, with the wire over-running the CTD. Further discussion of these aspects occurs in other sections

4.7 RECORDING RATE

It is advisable to record data at the maximum rate available as this will give some increased scope for filtering of the data later.

4.8 CALIBRATION AND COMPARISON

It is clear that a poor calibration can be seriously misleading. Experience has shown that it is unwise to assume that laboratory calibration of the conductivity sensor will remain stable over a cruise: further checks by means of Nansen cast or analogous means of sample collection are essential.

We emphasise that, if the CTD cast and corresponding Nansen measurements are not taken with great care, accurate calibration is impossible. The Nansen cast data should ideally cover the range of temperature, salinity and pressure encountered. If no rosette sampler is available a Nansen bottle can be fixed to the cable some 2m above the CTD. (Note the risk that the messenger, which usually travels at 2-3 m/sec, may get stuck on the cable; while hoisting at high speed this can cause the cable to break as the messenger will not run through the winch block!). For comparison with Nansen samples the CTD is preferably positioned within a zone of small, preferably vanishing, vertical gradient. While one waits, typically for 5 minutes, for the deep-sea thermometers to adapt (if in use) to the surrounding temperature, the CTD data display is sampled and the values are entered into the CTD log. There may be problems in very calm **conditions or on a fixed platform with** flow blocking or self-heating if the CTD is held fixed. In this case having located a well mixed layer one can use a rosette or other electrically triggered bottle to take a sample on a second run through the layer.

At least two water samples are usually taken from each Nansen bottle. Sample bottles should be left with the residual sea-water sample in them and at the end of the cruise rinsed with fresh water and afterwards dried. They are stored with closed cap which must have an efficient plastic or rubber seal. Do not touch the upper edge of the bottle or the inside of the cap else salt from ones fingers will contaminate the sample. Both cap and bottle are rinsed several times with the sample water. It is more effective to rinse often with a little water at a time than seldom with a lot of water. The sample bottles are filled only up to 0.5 to 1 cm below the cap. Be sure that no water from the outside of the Nansen bottle drops into the sample and that the bottle is not leaking.

Pressure sensors can be statically calibrated precisely and reliably in the laboratory. It is also possible to test the static temperature dependence of the pressure reading but difficult to measure either the dynamic response or hysteresis. Useful static and dynamic calibration of the pressure sensor can often be done when the sea-floor is flat by comparing the pressure measurement with the difference between the depth of the instrument determined from the difference between precision echo- sounder observations on the ship and bottom pinger measurements from the CTD. If there is no alternative but to use reversing thermometers as a check on the temperature then those having a smooth correction curve are preferred. They should be calibrated every year particularly at the ice-point. Temperatures should be read carefully, by more than one person, using a magnifying lens, waiting at least 5 minutes for temperature equilibration.

5. DATA PROCESSING

5.1 INTRODUCTION

This chapter describes the problems, considerations, and possible approaches for processing CTD profile data. There are many different CTD instruments in use and the hardware design and method of operation will dictate the optimum processing scheme. This chapter is divided into 4 parts: Introduction, Definition of Terms, Data Processing, and Recommended practices. Appendix B contains additional information on Digital filters. There are two stages in CTD data processing; converting the data into physical units and correcting the data for instrumental and sampling aliases or biases.

5.1.1 Conversion to Physical Units

As recorded at sea, CTD data consist of digitised voltages or frequencies acquired from in-situ sensors at predetermined intervals of time. Typically these intervals are generally equally spaced at 1 second or less, although some systems record at predetermined pressure intervals. The pressure interval technique is not recommended if time lag corrections are required. Raw data values must be converted to physical units of conductivity, temperature, and pressure. They also must be edited to remove

clearly erroneous values. After this first stage of processing, the dataset should have the uniform characteristics of being equally spaced in time and being in a readable form on a convenient Storage medium.

5.1.2 Adjustments to the Data

The second stage is to correct the data using calibrations and known sources of errors. It is desirable to minimise the amount of processing required bearing in mind the potential accuracy of the acquisition system as well as the desired accuracy for the intended use of the data.

5.2 DEFINITION OF TERMS

Accuracy: The root-mean-square deviation will be used as the measure of accuracy.

Compaction: Compaction of data is the process of reducing the number of data values used to describe the measured environment. Common techniques of compaction would include: decimation, subsampling, interval averages, or flexure points.

Dataset: The collection of data values collected during a single CTD cast.

Editing: Editing is the removal of individual data values thought to be erroneous from the data set. New values or default "missing" values may be inserted to preserve the time sequence.

Errors

Random Errors: Random errors develop from the electronics and coupling devices within the CTID system and are distributed uniformly in the frequency domain.

Biases: These are shifts in calibration which are generally constant during a cast but may change from cast to cast.

Trends or Drift: These errors are introduced by steady long term drifts in calibration of sensors over periods of days and are characterised by predictable values.

Scaling: By scaling is meant the conversion of raw values into physical units of temperature, pressure and conductivity.

Time Lag: A delayed response of one sensor relative to the output of other sensor.

5.3 DATA PROCESSING

5.3.1 General View of Processing

Scale to physical units

The raw data are generally digitised voltages, frequencies, or periods. These raw digital values must be scaled to appropriate physical units such as decibars for pressure, °C for temperature, ratio for conductivity, and Practical Salinity for salinity.

Edit and filter

In this stage, data values which are not physically realisable are eliminated by using maximum and minimum bounds derived from instrument range and/or typical climatological data.

Another process in this stage is ensuring that no unrealistic discontinuities exist within the data. Typically this editing is based on maximum allowable gradients or deviations between adjacent values. Statistical schemes can be used to identify values which deviate by more than a given number of standard deviations from a general curve fitted through a small section of the dataset.

Smoothing of the data (low-pass filtering) may be performed to reduce the random noise in the data.

Finally, data values are substituted for time intervals where no data is available. This allows subsequent processing to be performed on an equally spaced series.

Time lag correction

The data are corrected to account for the different lag responses of the various sensors. Usually the temperature sensor has a significantly longer time constant than either the conductivity or pressure sensors.

Miscellaneous Adjustments

Adjustments may be required to temperature, pressure, or conductivity because of variations in calibration during the cast or because of sensor design or arrangement. These adjustments are completed after the time lag corrections but before salinity is computed.

Computation of Salinity

Salinity is computed as a function of temperature, pressure, and conductivity values. The 1978 definition of salinity (UNESCO, 1981) should be used for all computations. Values of salinity acquired during periods of poor flushing of the conductivity cell should be discarded.

Compaction

The dataset is compacted to bring it to a usable resolution in time and space. The sequence of editing, smoothing, and substituting into the series prior to time lag corrections or salinity computation is necessary since time derivatives are used in the correction and the algorithm for salinity is highly nonlinear.

5.3.2 Details of Processing Scaling

Scaling is a process with very little option available to the investigator. The instruments produce signals which must be scaled according to the appropriate calibration for each individual sensor.

Editing and Filtering

There is no procedure for editing data which will apply to all cases. Each investigator must design his scheme to the characteristics of his raw data.

Extreme Data Values: An initial improvement in the data is the removal of values which are instrumentally impossible or climatologically unreasonable. The detection of erroneous data values is accomplished by comparison with maximum and minimum bounds of acceptable values.

A more sophisticated (and expensive) data dependent editing scheme is based on statistical properties of the data. An analytical curve is fitted to a subset of the data using least squares techniques, and all values in the subset which deviate more than a given number of standard deviations are deleted. The investigator must take care that such a curve fit is reasonable for the particular environment in which he is gathering data and that the window and length of fit are well matched.

Replacement of Edited Values: In order to maintain an equally spaced dataset, edited or missing data values should be replaced with expected values. Expected values should be derived by either linear or second order interpolation, depending on the observed trend in the dataset for the affected part of the water column.

Filtering and Smoothing (filter design): Certain correcting algorithms (e.g. time lag and fall velocity) require derivatives of the data series for computations. Random errors within the dataset can cause large errors in these estimates, especially when the signal to noise ratio is small. Digital low-pass filters are used to reduce random errors in the dataset. The goal is to attenuate the noise in the data without affecting the signal content. Any filter used will attenuate both the signal and noise, however, so that at

frequencies where the signal to noise ratio approaches or is less than unity, the signal will be lost. The minimum possible noise content, E , in the recorded data is that generated by quantisation. This level can be estimated as:

$$E = \Delta^2 / 12 \text{ (analogue)} \tag{5.1}$$

$$E = \Delta / 6 \text{ (period or frequency digitising)}$$

where Δ is the least count value of the digitising (Irish and Levine, 1978). The variance of this noise is distributed as white noise in the frequency domain. To this noise must be added noise introduced from other sources in the acquisition hardware. Two cautions must be made in performing filtering. First, the filtering should not introduce phase shifts in the signal. This requires that a symmetrical digital filter must be used. Second, it should be remembered that the sharper the cutoff in the frequency response of the filter, the more will be the oscillations (Gibbs phenomena) in the output of the filtered data. Figure 5.1 shows the frequency responses for some commonly used filters. Specifications and weights of some of these digital filters are contained in Appendix B Table B.1. These symmetrical digital filters are applied with the following algorithm:

$$X'(n) = W(0)X(n) + \sum_{k=1}^{k=K} W(k)[X(n-k) + X(n+k)] \tag{5.2}$$

where the filter $W(k)$ of K weights is applied to $2K+1$ data points in series $X(n)$ yielding the filtered data series $X'(n)$. The frequency response, $R(f)$, of these symmetric filters was computed using the relationship:

$$R(f) = W(0) + 2 \sum_{k=1}^{k=K} W(k) \cos(2\pi f k) \tag{5.3}$$

Additional information on digital filtering can be found in Cold and Rader (1969) and Holloway (1958).

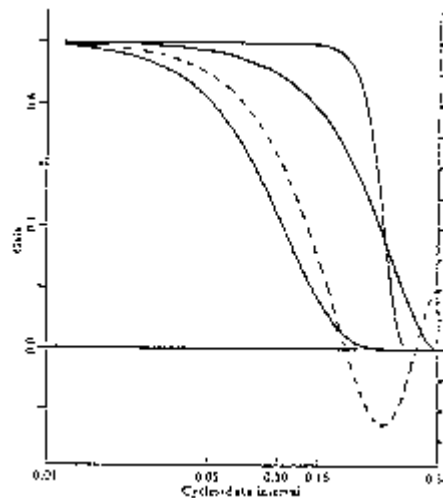

Running Mean 5 points	-----
Stop band starts (1%gain)	0.195
Max overshoot	-25.07c at 0.289
Elementary Binomial	_____
Stop band starts (1% gain)	0.465
Max overshoot	0.0% at 0.289
Normal Curve $\sigma = 2$
Stop band starts (1% gain)	0.238
Max overshoot	0.0% at 0.500
Filter #4 App. B.4 10 weights	_____
Stop band starts (1%gain)	0.355
Max overshoot	0.4% at 0.406

Figure 5.1: Frequency responses of selected filters

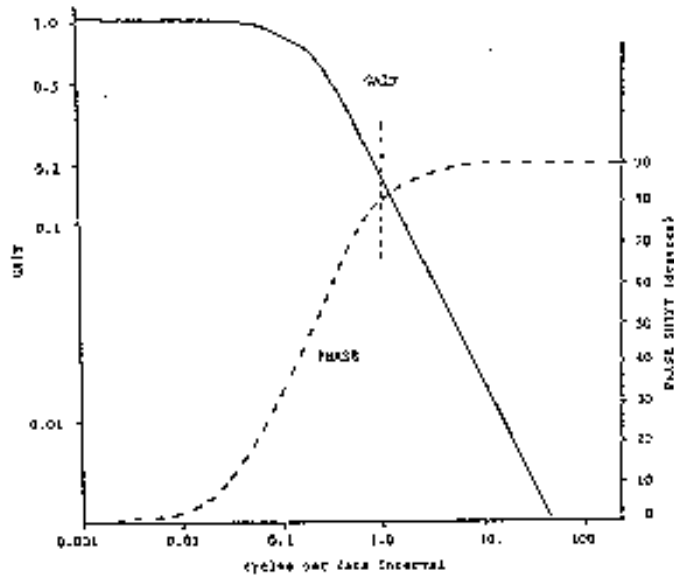

Figure 5.2: Complex frequency response of analogue time lag operation

Time Lag Correction

The purpose of time lag correction is to remove the effect of the mismatch in time constants between the temperature sensor and the depth and conductivity sensors. The response of simple thermometers is modelled by an exponential decay such that the rate of change of the sensor output T_0 is proportional to the instantaneous error in measurement ($T_1 - T_0$):

$$\frac{dT_0}{dt} = \frac{T_1 - T_0}{\tau_l} \quad (5.4)$$

Where τ_l is the time constant of the sensor. As seen in figure 5.2, the frequency response function of this analogue transfer function attenuates and introduces a phase shift into the high frequency part of the signal. By itself, the attenuation is not of real concern since typically the measurements contain higher frequency content than are required. However, the phase shift introduces a delay into the signal which causes the temperature data to be non simultaneous with the conductivity data; this generates salinity biases. This distortion is evident at frequencies greater than $1/(20 \tau_l)$. Two basic approaches can be used for time lag correction:

1. removal of the shift from the measured temperature values or
2. adding a shift to the conductivity and pressure values so the time lags of all the sensors are equal.

Historically, the approach has been to attempt removal of the shift in the temperature data (Scarlet, 1975; Fofonoff et al. 1974; and Millard et al. 1980). However, in recent years more emphasis has been put on adding time shift to the other sensor series since computationally it is simpler and noise amplification is eliminated (Walker, 1978). Moreover, it has been recognised that the responses of conductivity cells are not instantaneous but depend on the CTD lowering rate as discussed in appendix A. Thus a complete treatment of lag correction should include these velocity effects.

Six cases will be presented describing the various methods which can be used for performing lag corrections on CTD data. The first 3 cases deal with methods for removing the lag effects from the data (temperature) in an attempt to match the sensor responses at the time constant of the faster sensor (conductivity). None of these three methods are recommended but are included for historical purposes and for completeness. The last three cases describe methods for adding lag effects so that the data all

contain the same effective lag responses. In general, these techniques are preferred over the lag removal techniques described in cases 1, 2, and 3. Case 6, adding lag responses which include the velocity dependent nature of the conductivity response is the preferred method for lag correction because of its completeness. As an alternative; case 5, adding lag response containing only simple exponential time effects, is highly recommended.

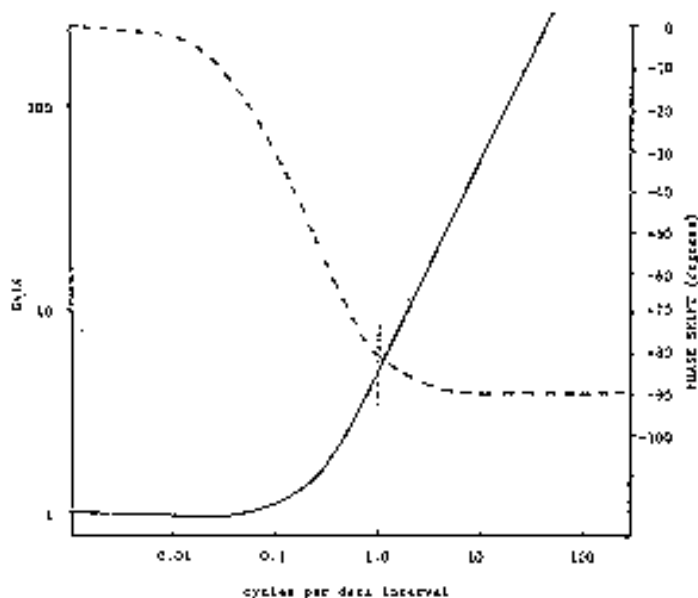

Figure 5.3 Complex frequency response of analogue lag correction scheme

It should be noted that none of the 6 methods described utilise our full understanding of the response behaviour of the CTD sensors and all use simplifying assumptions. In particular, the most common assumption is that simple exponential decay, or at most dual exponential decay, properly describes the responses of the sensors.

1. Lag correction applied to the temperature series.

Based on the assumed exponential decay model, recovery of the signal is accomplished by adding a correction derived from the instantaneous time derivative of the output signal:

$$T_c = T_0 + \tau_l \frac{dT_0}{dt} \quad (5.5)$$

where T_c is the corrected temperature. The frequency response function of this correction scheme is shown in figure 5.3. This correction scheme amplifies and phase shifts the measured values to restore the true values.

If the data acquisition system were strictly passive and added nothing except the exponential lag response, the above scheme would fully correct the data and the corrected output T_c would be equal to the input signal T_0 . Acquisition systems, however, introduce noise into the recorded data. This noise is not attenuated by the lag response but will be amplified by the correction scheme. Through the correction process, this noise can become larger than the signal. Thus it is usually necessary to reduce the noise content by low-pass filtering.

CASE 1: Sampling interval greater than time constant

The simplest time lag correction scheme is a direct implementation of equation 5.5 using the two adjacent temperature values to estimate the derivative as described by Scarlet (1975). For the j th temperature value:

$$T_c(j) = T_0(j) + N_l[T_0(j+1) - T_0(j-1)] \quad (5.6)$$

where N_l is the time lag expressed in terms of sampling intervals $N_l = \tau_l / \Delta t$. This algorithm is only appropriate when the sampling interval, Δt , is larger than the time constant (Scarlet, 1975).

CASE 2: Sample interval less than time constant

For the situation where the sampling interval is shorter than the time constant and the noise content of the data is not negligible, the time derivative should be approximated by a Least Squares slope as detailed in Fofonoff et al. (1974, p18 eq.14,15):

$$T_c(j) = \sum_{k=-l}^{k=N} A_k T_0(j - N/2 + k) \quad (5.7)$$

where the filter weights, A_k , for Least Squares smoothing are:

$$A_k = \frac{1}{N} + N_l \left| \frac{(12k - 6(N+1))}{(N(N^2 - 1))} \right| \quad (5.8)$$

and the sum of the weights is unity. Details of the choice of N and its effect on noise level can be found in Fofonoff et al.

Two value estimation ($N = 2$) degenerates to using first differences and effectively follows the exact transfer of the analogue correction. Three value least square regression attenuates at higher frequencies in a simple manner, while higher order smoothing creates multiple lobes in the response. Three value Least Squares estimation of the gradient is recommended for removal of simple exponential lag response.

CASE 3: Higher order response models

The exponential decay model is not exact for simple thermometers (Hurst, 1975) and can lead to serious errors when used to model compound thermometers (Millard et al, 1980). For compound thermometers, the decay model can be generated empirically from the observed or derived response function of the sensor. As outlined by Millard et al. (1980), these response functions can be estimated from the phase and coherence between conductivity and temperature data collected in a region with a well defined temperature-salinity relationship. A digital filter, $W(k)$, can then be designed using Least Square techniques to approximate the inverse of this response function (Horne and Toole, 1980) which can be used to correct the measured temperature:

$$T_c(n) = \sum_{k=-M_1}^{k=M_2} T_0(n+k) \cdot W(k) \quad (5.9)$$

where $W(k)$ are the weights of the non-symmetric filter approximating the inverse response of the sensor. If further smoothing of high frequency noise is required after time lag corrections using any of the above techniques, the corrected data can be filtered again. For this situation the final transfer function will be the product of the response of the time lag correction, $R_l(f)$ and the final filter, R_f .

$$R'(f) = R_l(f)R_f(f) \quad (5.10)$$

The total noise increase can be determined by integrating the final transfer function (equation 5.10) from 0 to the Nyquist frequency. The minimum accuracy of the corrected data can then be estimated by multiplication of this increase by the digitising noise estimated from equation 5.1.

2. Lag correction applied to associated variables.

Rather than attempting to correct the sampled data to true values, it is possible to adjust the faster responding parameters so that the responses of the temperature, conductivity, and pressure data are all

equal and equal to that of the slowest sensor (temperature). The effect of applying a time lag to the faster sensors during processing has two advantages:

- It is computationally simple and easy to implement and
- Noise amplification at high frequencies is avoided.

An additional benefit from this method is the effective low pass filter gained by application of the lag correction. Separate filtering for noise removal thus may not be necessary. The disadvantage in this procedure is the suppression of fine structure content of the series. For most applications this is not critical since data at 1 or 2 decibar intervals will not contain fine-structure and most sensor systems are not designed for such high resolution measurements. Another slight drawback is the loss of the first part of the data series, $3\tau_l / \Delta t$, because of poor correction at the start.

CASE 4: Recursive digital filtering

The most general implementation to add time lag response to data is by using a recursive digital filter:

$$X'(n) = W(0).X(n) + \sum_{k=1}^{k=K} W(k) X'(n - k) \quad (5.11)$$

where the sum of the filter weights, $W(k)$ is equal to unity.

The response function of equation 5.11 is given by:

$$R_l(F) = \frac{W(0)}{1 - \sum_{k=1}^{k=K} W(k) \exp(-i^2 \Pi f k \Delta t)} \quad (5.12)$$

where f is in units of cycles per sampling interval.

CASE 5: Exponential lag response

Simple exponential lag response for a time constant of τ_l , seconds and a sampling interval of Δt seconds can be achieved from equation 5.12 by letting $K=1$, $W(0)=1-\exp(-\Delta t / \tau_l)$, and $W(1) = \exp(-\Delta t / \tau_l)$.

$$X'(n) = [1 - \exp(-\frac{\Delta t}{\tau_l})].X(n) + \exp(-\frac{\Delta t}{\tau_l}).X'(n-1) \quad (5.13)$$

Millard has evaluated this technique (equation 5.13) in comparison to a transverse filter designed to correct for higher order lag response (equation 5.10) as derived by Home and Toole (1980) and found no apparent differences in salinity to 0.002.

CASE 6: Velocity dependent exponential lag response

As discussed in appendix A, the response of conductivity cells can be described by a distance, related to cell geometry, at which 63% of a step change is recorded. As a first approximation for conductance cells this "distance constant" (D) is about 55% of the cell length (for inductive cells it is probably equal to or greater than the cell length because of far field effects). Through the lowering rate of the CTD, $W(t)$, this distance constant can be transformed into an effective time constant, T_c , for the cell by:

$$T_c = \frac{D}{V(t)} \quad (5.14)$$

Because of noise, the pressure data should be severely filtered to eliminate high frequency content before being differentiated to estimate the lowering rate.

Using equation 5.14, we can match the responses of the conductivity sensor to that of the thermometer by adding a lag related to their time constant differences:

$$\tau = \tau_1 - \tau_2 \quad (5.15)$$

The recursive correcting algorithm (equation 5.13) then becomes:

$$C'(n) = [1 - W(l)].C(n) + W(l).C'(n-1) \quad (5.16)$$

where:

$$W(l) = \exp\left[-\frac{\Delta t}{T_c - D/V(n)}\right] \quad (5.17)$$

It should be noted that at slow lowering rates, the effective cell time constant becomes large and, at a critical velocity V_c , it will be equal to that of the temperature sensor time constant τ_1 :

$$V_c = \frac{D}{\tau_1} \quad (5.18)$$

Assuming the shape of the response functions are similar, then no further lag corrections would be required. At speeds much below this critical velocity (and upcast speeds where the data are distorted by the turbulent wake of the CTD) the conductivity data are probably unreliable because of self-heating. Salinities derived during these slow lowering speeds should be disregarded. Operationally, this method can be implemented by shifting the parameter to be corrected from conductivity to temperature when the lowering speed is below the critical velocity.

For $V(l)$ greater than V_c :

$$C'(n) = (1 - W(l)). C(n) + W(l).C(n - 1) \quad (5.19)$$

$$T'(n) = T(n)$$

$$W(l) = \exp\left[-\frac{\Delta t}{T_c - D/V(n)}\right]$$

For $V(t)$ equal to V_c :

$$C'(n) = C(n) \quad (5.20)$$

$$T'(n) = T(n)$$

And, for $V(t)$ less than V_c :

$$C'(n) = C(n) \quad (5.21)$$

$$T''(n) = (1 - W(l)). T(n) + W(l). T''(n - 1)$$

$$W(l) = \exp\left[-\frac{\Delta t}{(D/V(n) - T_c)}\right]$$

For this comprehensive approach (equations 5.19 to 5.21), salinity values computed at lowering speeds less than 1/4 of the critical velocity should be discarded during compaction. However during the correction, these very low or negative speeds should be replaced by $0.25V_c$: to avoid numerical difficulties and to maintain the recursive algorithms. Where the lag response to be added is more complex than that approximated by the simple exponential decay model, a recursive filter of a few weights can be derived using Least Square techniques to match equation 5.13 to the desired response function.

Since adding lag distortion only requires past historic information in the data series, this approach for time lag correction is very simple to implement and very efficient. The first few seconds of filtered output will not be fully corrected (approximately $3 \tau_1 / \Delta t$ data values) and should be discarded.

3. Frequency Domain Approaches

There are two possible implementation techniques for applying lag corrections to discretely sampled data, either in the frequency domain or in the time domain discussed above. Physically they are

equivalent. The frequency domain approach entails computing the Discrete Fourier Transform (DFT) of the recorded data, applying a complex correction (multiplication by $[1 + 2i\pi f \tau_1]$ for simple exponential decay model) and then performing an inverse DFT to regenerate the corrected data. This approach has not been used in the past. In its simplest form, the processing would be as follows for lag correction:

- (a) Perform an aperiodic Discrete Fourier Transform (DFT) on the temperature time series using any of the Fourier or Fast Fourier Transform techniques (such as Cold and Rader, 1969):

$$F_0(f) = DFT[T_0(t)] \quad (5.22)$$

- (b) Multiply each of the frequency estimates by the inverse of the lag response to determine the corrected Fourier transform:

$$F_c(f) = F_0(f) \cdot R_l(f) \quad (5.23)$$

Where $R_l(f)$ is the inverse of the lag response (for the simple exponential decay model $R_l(f)$ is equal to $(1 + 2i\pi f \tau_1)$)

- (c) Resynthesize the corrected time series by performing an Inverse aperiodic Discrete Fourier Transform:

$$T_c(t) = DFT^{-1}[F_c(f)] \quad (5.24)$$

Smoothing can be easily added to the processing by multiplication of the corrected Fourier Transform by the response function of the desired filter, $R_f(f)$, before resynthesis:

$$F'_c(f) = F_c(f) \cdot R_f(f) \quad (5.25)$$

The great advantage of this approach is the simplicity of changing the filter characteristics in the software. The filter is easily specified and can be tailored directly to the desired response. The disadvantage is that it can cause severe oscillations in the resynthesized time series which then propagate from the ends towards the middle. This phenomena is compounded by the input time series having a trend (temperature decreasing with depth) which requires Fourier components similar to that of a saw tooth wave to reconstruct it. Many of these components have substantial amplitudes at high frequencies which the time lag correction may amplify. To reduce these oscillations caused by the periodic nature of the DFT, it is possible to divide the original time series into short sections overlapping by 1/4 or 1/3 sections and using only the non-overlapping portion to reconstruct the corrected data. In addition it may be useful to remove any linear trend before the DFT is computed and restore the trend after resynthesis, along with a constant lag correction to account for the trend (τ * slope of trend).

Frequency domain techniques can also be used to add lag effects to the conductivity and pressure data. For this use, the response function, $R_l(f)$ in equation 5.25, would be the actual lag response of the temperature sensor rather than its inverse. For those instruments where the lag responses of the conductivity and pressure sensors are not near unity (time constants not equal to 0) this response function, $R_l(f)$, would be the ratio of the temperature response divided by the conductivity or pressure response as appropriate.

In general, for either of the approaches to time lag correction discussed above, special operations must be included to prevent the undesired amplification of the noise into the corrected data. For the time domain approach this is accomplished by low pass filtering. For the frequency domain approach, this is accomplished by filtering and overlapping of the data sections during processing.

Miscellaneous Adjustments

Adjustments may be necessary in order to make the conductivity and temperature values correspond to the same horizontal pressure level and to account for *in-situ* calibrations.

Adjustments for Pressure Level: Depending on the mechanical configuration of the sensors on the instrument, the sensor sampling sequence, and any delays introduced by time lags, it may be necessary to adjust the dataset so that the values of temperature and conductivity correspond to the same pressures. Linear interpolation between data values should be used to make this adjustment.

Corrections for *in-situ* Calibrations: Any precision sensor may shift its calibration as a function of time and CTD sensors are no exception. Since the relationship between temperature, conductivity, pressure and salinity is nonlinear, any calibration shifts must be applied before the computation of salinity. These corrections are determined using independent measurements of these values *in-situ*.

Zero pressure correction is determined by wire angle and length for a shallow depth of about 1% of full scale pressure. This zero pressure should be used to correct the pressure data for each lowering to account for the small random bias in depth caused by the initial non-linearity of sensor output as it departs from its rest value at zero pressure.

For conductivity, a modified cell constant can be computed by measuring the salinity of a water sample acquired *in-situ* and deriving the "true" conductivity using corrected pressure, temperature from the CTD, and this salinity value. Data from several casts should be used to determine this modified cell constant. A more complete description of how to determine these corrections can be found in chapter 3.

Computation of Salinity

Salinity is computed from corrected, *in-situ* values of temperature, conductivity, and pressure using the salinity definition of 1978 (Appendix D). To maintain comparability between different data sets, no other algorithms should be used.

Removal of Erroneous Salinity Values

We now have a complete time series of corrected temperatures, corrected pressures and computed salinities at the original sampling interval. Scarlet (1974), Walker (1978), Gregg et al. (1981), and Topharn (1981) describe the responses of some conductivity sensors. These responses are not instantaneous and require flow through their bore to maintain calibration. Under low flow conditions, water is trapped inside the cell, usually at the sides, and thus the mean conductivity of the water within the cell is not the same as that outside in the water column. This is particularly true when large gradients are present.

Because these errors are difficult to determine or model analytically, the investigator should discard all salinity values corresponding to times when the flow through the conductivity sensor is less than that required for proper flow or when the lowering speed is so slow that the effective time constant of the conductivity cell is much larger than that of the temperature sensor. In addition, downcast data acquired while the CTD is moving upwards during wave motion should also be discarded because water entrained by the shape of the CTD will alter the water column being measured. For this same reason, upcast data should not be reported. Flow conditions through the conductivity sensor may also be low when the downwards velocity approaches or is equal to the terminal velocity of the CTD. At these speeds the instrument may be tumbling or moving sideways because of the weight of the cable.

To make these deletions for low flow conditions, the velocity of the CTD is calculated from the pressure data. Since the resolution of the pressure sensor is relatively coarse and has a high noise content, filtering is necessary. Either low-pass filtering (equation 5.2) followed by differencing:

$$\frac{dP'}{dt} = \frac{P'(n+1) - P'(n-1)}{2 \Delta t} \quad (5.26)$$

or gradient estimation by linear Least Squares can be used to determine the velocity of the CTD. Linear least squares estimation using $2K+1$ data values is done according to:

$$\frac{dP'}{dt} = \frac{\sum_{k=1}^{k=K} k \cdot P(n-k)}{2 \sum_{k=1}^{k=K} k^2} \quad (5.27)$$

The larger the number of data values used in equation 5.7, the smoother will be the estimate of the gradient. If the variation of pressure with time is not linear over these $2K + 1$ data intervals then the estimate will deteriorate and low-pass filtering would be a better approach. The number of data intervals, $2K + 1$, included in the least squares estimation should not greatly exceed the reciprocal of the sampling interval in seconds. This preserves the ship roll signal in the series (= 4 sec period). The mass of the CTD and constant winch speeds allow severe smoothing on the depth data. Cutoff frequencies of from 1 to 2 hertz are not unreasonable unless ship roll motions are quite irregular or markedly nonsinusoidal.

Compaction

The purpose of compaction of the dataset is to reduce the dataset to a manageable size and to make the dataset monotononic in pressure. Two techniques are routinely used: averaging within pressure (depth) intervals (baskets) and representation by flexure values. For most applications the data stored by either technique are equivalent. However, the spectrum of the reconstituted data and the extreme values may be different between the two methods.

Pressure Interval Averaging (Basketing): The most common form of compaction is forming arithmetic averages of temperature and salinity for a set of desired pressure intervals (δp). Except for micro- or fine-structure instruments, the pressure interval should not be smaller than 1 decibar. The reported pressure of each interval should be the centre of the interval (i.e. 50 decibars would represent the interval from $50 - 6 p/2$ to $50 + 6 p/2$). Only valid, corrected data are used to compute the average within each averaging interval.

Flexure Value Compaction: Another method for compacting data is by derivation of flexure points. This method is predominantly used by archive centres because of the significant reduction in volume of data. The complete valid dataset is stored by saving the ends of straight line segments which when joined end for end, will duplicate the high resolution set with no deviations between the straight line segments and the original dataset greater than a predetermined error (flexure criteria). Fig 5.4 shows an example of high resolution data and flexure points which reproduce these data to a known uncertainty.

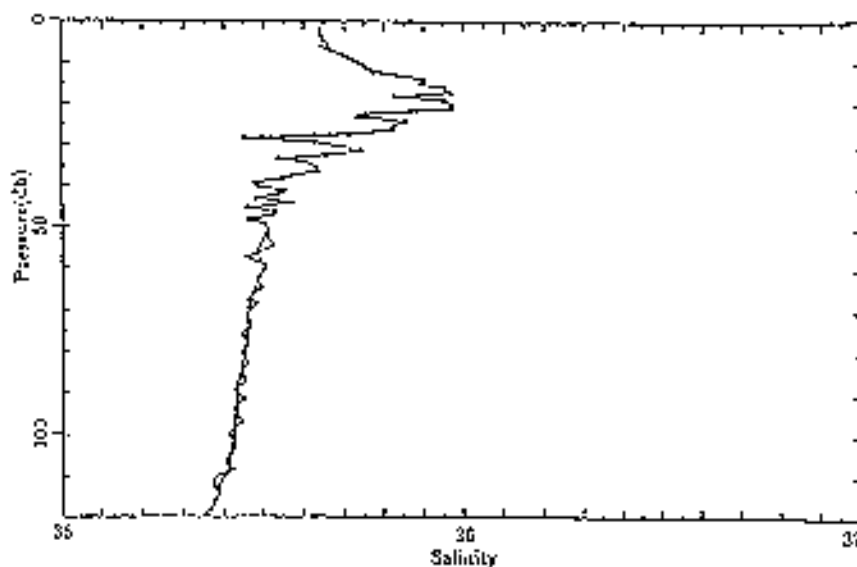

Figure 5.4: Compaction of data by flexure points. Error in $S < .04$ and in $T < .03$

5.4 RECOMMENDED PRACTICES

5.4.1 Time Lag Corrections

For the processing of non fine structure temperature and salinity profile data (output data intervals of 1 or 2 decibars) the recursive filtering technique (equation 5.13) to generate uniform lagged responses for temperature, conductivity, and pressure is highly recommended. For more comprehensive correction, the recursive technique is still recommended, but the filter should be designed to match the differences in actual lag responses of the sensor pairs (equations 5.13 and 5.14) (CASE 4) and account for the velocity dependence of the cell response (equations 5.18 and 5.19) (CASE 6).

5.4.2 Units

The recommended units are degrees Celsius (°C) for temperature data, milli-Siemens (mS) for conductivity and decibars (dbar or 104 Pascals) for pressure. Practical Salinity is dimensionless. If the pressure data are converted to depth (not recommended) using the hydrostatic relationship, the units should be reported in meters (m).

5.4.3 Precision

Data values should be reported with sufficient precision to insure that meaningful truncation does not occur. This precision should have the least significant digit one order of magnitude better than the accuracy of the value (a value with an accuracy of 0.02 should be reported to a precision of 0.001 units). Recommended minimum precisions for reporting data are: 0.001deg C for temperature, 0.001 mS for conductivity, 0.001 for salinity, and 0.1 dbars for pressure.

6. GUIDELINES FOR EXCHANGE¹

6.1 INTRODUCTION

It is recognised that, with modern CTD systems and careful *in-situ* calibration, it is now possible to obtain good quality, high resolution vertical profiles of temperature and salinity (or conductivity). It is also recognised from past experience that the majority of secondary users are likely to prefer compressed versions of these data, at intervals more compatible with classical water bottle data or the ICES STD Standard Criteria of 1969. However, in satisfying this majority user need, it is important to ensure that good quality, high resolution data are not lost to those scientists that require them. Laboratories should endeavour to maintain versions of these data with minimal loss of information, in addition to any compressed versions that might be prepared for more general use.

These guidelines relate specifically to data maintained to minimise information loss, rather than to versions compressed to satisfy particular user needs. It is, however, recognised that on occasions these two versions may sometimes be one and the same, and that on occasions data compression techniques may be applied without significant loss of real information.

6.2 DATA STANDARDS

1. As a matter of routine, data should not be exchanged at a finer resolution than 2 decibars in oceanic depths, and 1 decibar in continental shelf depths. Only if the data have been collected for some specialist study, e.g. micro- or fine-structure measurements, should finer depth resolutions be considered.

It is recognised also that in many cases calibrated data sets may only have been produced to coarser resolutions arising either, for example, from the circumstances of the instrument performance, or from the nature of the data originator's investigations.

¹These were initially developed by the ICES Working Group on Marine Data Management

The recording of data at flexure points may be seen as a means of achieving economy of storage relative to recording at fixed pressure intervals. If this technique is used, there should not be significant loss of information about the profile in comparison with fixed pressure interval data prepared according to the above.

2. All relevant corrections should be applied to the data including instrumental calibrations, and field corrections. The data should be fully checked for quality and pre-edited or flagged for erroneous values such as spikes, gaps etc. An explicit statement should be made of the correction, checks and editing applied to the data.
3. If available, the reference values used for *in-situ* calibration /comparison (for example reversing thermometer measurements, bottle salinities), should accompany the data.
4. Sufficient self-explanatory series header information and documentation should accompany the data so that they are adequately qualified and can be used with confidence by scientists and engineers other than those responsible for their original collection, processing and quality control
5. All data values should be expressed in oceanographic terms, in SI units, (although decibars are permitted alternative) which should be clearly stated. Salinity values will be expressed in Practical Salinity Units and should be clearly distinguished from the earlier pre-1978 definition of salinity.
6. Other parameters measured as part of the series e.g. sound velocity, oxygen, should be included with the data.
7. Unless calibrated against depth measurements, the data cycles should include pressure and not depth. If conductivity is included instead of salinity, then pressure should always be included.

6.3 FORMAT STANDARDS

1. Data should be exchanged in GF-3 format. An example is given in Appendix C
2. Guidelines for the formatting of CTD data in GF-3 may be obtained from: RNO DC (Formats), ICES Service Hydrographique, Palaegade 2-4, DK-1261 Copenhagen K, Denmark or from Marine Information and Advisory Service, Proudman Oceanographic Laboratory, Bidston Observatory, Birkenhead, Merseyside L43 7RA.

6.4 SERIES HEADER INFORMATION

Each CTD series should include entries in the appropriate GF-3 fields for the following:

1. Name of the country and organisation responsible for collection and processing of the data.
2. Project, platform (e.g. ship) and cruise identifiers.
3. Dates and times of start and end of CTD cast.
4. Originator's reference number/ identifier for the series.
5. Latitude, longitude, (start and end positions if known) and sea floor depth.
6. Reference values collected for *in-situ* calibration /comparison e.g. reversing thermometer measurements, bottle salinities.

6.5 DATA DOCUMENTATION

Sufficient plain language documentation should accompany the data so as to ensure that they are adequately qualified and may therefore be used with confidence by a secondary user. Such documentation should be included within the plain language part of the GF-3 format and, where

applicable, should cover all items listed below. (Note that a worked up example of a fully documented CTD series may be found in the GF-3 guidelines referenced in 6.3.2.).

1. Instrumentation:

- (a) Description of each instrument used-manufacturer and model number. Refer to publication or briefly describe.
- (b) Instrument modifications and their effect on the data.

2. Data Collection:

- (a) Description of operational procedures for collecting CTD data and *in-situ* calibration data indicate whether data are from down cast or some combination of down and up casts
- (b) Sampling rate, sensor resolutions, and lowering rate-indicate any changes during the cast.
- (c) Method to monitor CTD depth or CTD height above sea floor.
- (d) Methods of position fixing and sea floor depth determination

3. Data Calibration/Quality: for each parameter or sensor

- (a) Type or principle of sensor (e.g. platinum resistance, thermistor).
- (b) Method, quality (including response range) and dates of sensor calibration.
- (c) Method and quality of *in-situ* comparisons.
- (d) Report on corrections applied to data including corrections for bias, drift, calibration and system malfunctions, and
- (e) Estimate of final uncertainty in the data as evidenced by the calibrations and comparisons, and by sensor performance.

4. Data Processing: brief description of processing procedures (and their sequence) used to obtain final data values starting from original samples including

- (a) filtering/ de-spiking/ smoothing methods.
- (b) editing/quality control procedures-indicate how missing or erroneous data were identified and treated.
- (c) time lag correction scheme (for each sensor in question) and values used.
- (d) adjustments made because of variations in calibration during cast or because of sensor design and arrangement.
- (e) computation of salinity.
- (f) pre-sorting of data by pressure.
- (g) data compression method e.g. pressure interval averaging-state the interval, flexure point compression-state the criteria averaging over n original data cycles edited version of original dataset.

5. Report any additional item or event that may have affected the data, or have a bearing on the subsequent use of the data.

SECTION 2.1 APPENDIX A THE DESIGN OF OBSERVATIONAL PROGRAMMES

A.1

Several decisions must be made.

1. Decide the depth intervals d for which representative salinity and temperature values are required. This means that the smallest feature required to be observed in the ocean should exceed $2d$.
2. Determine
 - (a) The time constant of the temperature sensor, τ_1 and of conductivity sensor, τ_2 (they may not be as quoted by the supplier)

If τ_2 is not available use $0.55L/V$ where L is the length of the cell and V the probe descent velocity. If possible choose V so that $\tau_1 \sim \tau_2$.

- (b) Time lag δt between the measurement of conductivity and temperature values in a single cycle.
 - (c) Time interval, Δt , between successive samplings of C , T and pressure.
 - (d) Does the instrument record every sample (at intervals Δt) or does it record a block average of N samples (at intervals Δt)?
- (c) Determine the sensor separation, h .
 3. If Δt is equal to or greater than τ_1 , construct $\tau_1^* = \tau_1 / \Delta t$ and $f^* = \Delta t V / d$ Use figure A.1 to estimate the extent of aliasing of higher frequencies.
 4. Determine the attenuation at the frequency of interest, $V/2d$, from the abscissa of Figure A.1a and decide if it is acceptable.
 5. If not, then alter d or the instrument time constants to suit, possibly by altering V to change τ_2 .
 6. Proceed to make measurements and calculate salinities as discussed in the chapter on data analysis.

7. Example. Suppose it is required to resolve 0.5 m "slices" of an oceanographic profile ($d = 0.5$ m). τ_1 , is given as 0.1s and L as 18 cm so that $\tau_2 = 0.55 \times 0.18 / V$. If the sample interval Δt is 0.15s then $\tau_1^* = 2/3$ and from figures A.1a and b aliasing will be about 10%. If 20% attenuation is acceptable at 1m wavelength then the figures show that $f^* < 0.36$. Thus $V < 1.2$ m/s. To match time constants $\tau_1 = \tau_2$, we need $(0.55 \times 0.18) / V = 0.1$ giving $V = 1$ m/s. The physical separation between the sensors could now be adjusted to compensate for the time interval δt , between their sampling in a single record. If $\delta t = 0.05$ s then $h = V \delta t = 1 \times 0.05 = 5$ cms. Alternatively and more practically, to cope with varying velocities of descent, (V variable) the time series for conductivity and temperature may be "slipped" i.e. interpolated by an interval $(h/V - \delta t)$ so that salinity calculation are carried out on values measured at the same location. Note that 7 measurements per meter are necessary to resolve the desired half meter slice thickness adequately at the selected 1 m/s lowering speed. $f^* = 0.3$ and Figure A.1 shows that the half meter signal is attenuated by only 15% by the sensor time constants, and that only 7% (Figure A.1a) and 3% (Figure A.1b) of any energy available at wavelengths of 18 cm and 13 cm respectively will appear aliased onto the 1 m wavelength record ($d = 0.5$ m).

A.2 SENSOR RESPONSE

To deal with the sometimes non-exponential response of the temperature system we shall generalise the concept of time constant (which strictly speaking applies only to the simple exponential rise) and define it as that time taken for the response to reach 63% of the amplitude of the temperature step.

Although the salinity calculation is not very sensitive to time constant effects in the pressure sensor, hysteresis problems can be important when the CTD is being lowered from a vessel subjected to major pitching and rolling which periodically alters the rate of descent. Under these conditions, the computation of the lowering rate from small pressure differences is usually made unstable by noise and resolution problems so that only greatly smoothed estimates of lowering rate can be obtained from the pressure record. These estimates are generally not good enough to aid in the reconstruction of small scale features through knowledge of the sensor response characteristics.

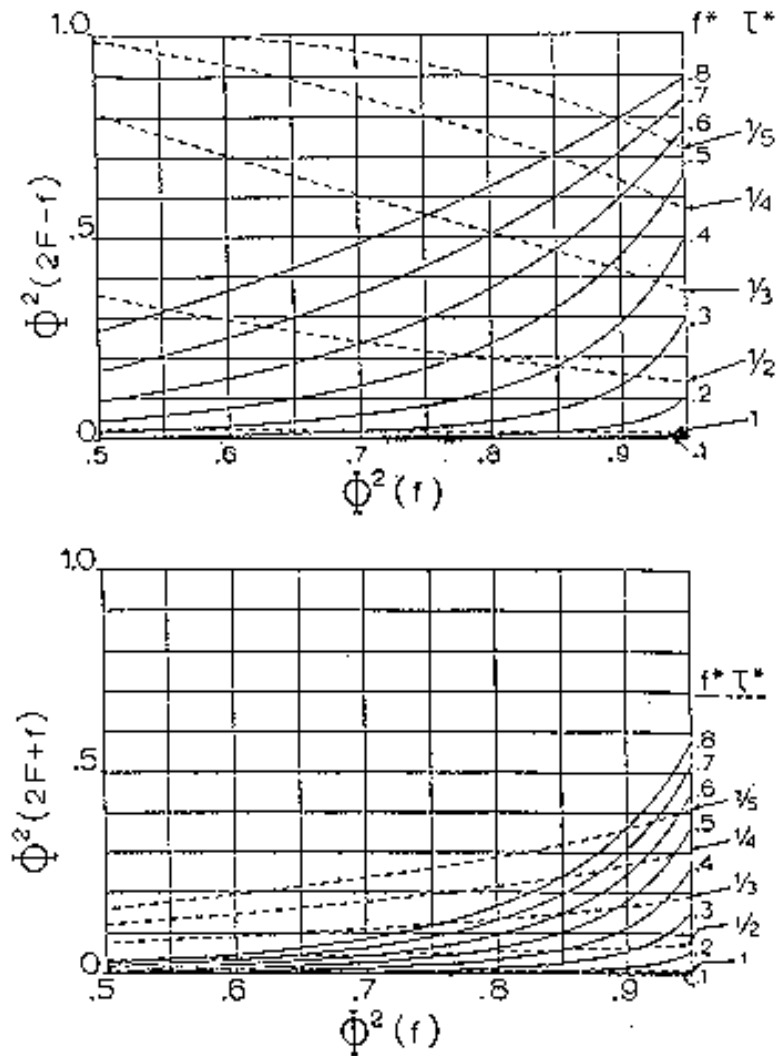

Figure A1: a) Nomogram relating frequency of interest, f , sampling interval Δt , time constant τ with signal attenuation $A(f)$ and aliasing. F is the Nyquist frequency, equal to $0.5\Delta t$ and, $\tau^* = \tau / \Delta t$, $f^* = f / F$. Entering with given values of the last two parameters gives signal attenuation at the frequency of interest (abscissa) and the proportion of any power existing at frequency $(2F - f)$ that will be aliased onto the frequency of interest (ordinate). b) Same, but for frequency $(2F + f)$.

A.3 SENSOR TIME CONSTANTS AND SAMPLING CONSIDERATIONS

In the usual CTD lowering, temperature, conductivity and pressure are sampled and recorded sequentially. Depending on the electronics available, a set of values may be available up to 25 times per second; in other systems one complete scan of all three sensors takes more than a second. The factors of time constant, lowering rate and sampling speed are all interrelated in planning to obtain optimum salinity information and the discussion of these inter-relationships is the main subject of this section.

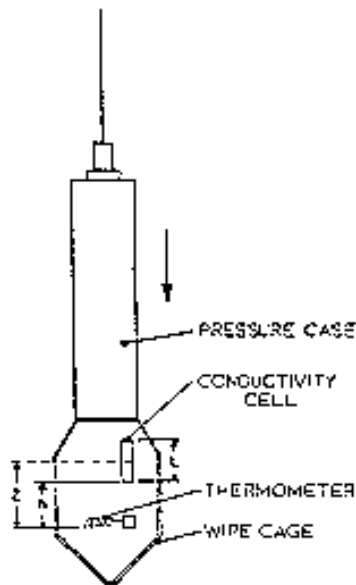

Figure A.2

To illustrate the problem involved take the case of slow sequential sensor sampling at a lowering rate of 1 m/s so that the instrument moves a significant distance during one complete scan of the sensors. Figure A.2 shows a sketch of the sensor positions on their protective cage beneath the CTD pressure case and defines appropriate geometric parameters. It is assumed that the sensors are sampled in the order pressure, temperature and conductivity. Very frequently sensors are mounted so that they are at the same horizontal level at any given time (i.e. $z = 0$) so that as the instrument is lowered through a sudden change in water properties the output of the temperature and conductivity sensors are not sampled when they are at the same position in relation to the discontinuity in water properties. For example, with a 1/3 sec interval between individual sensor sampling and a 1 metre/second lowering speed the sensor outputs are measured at positions 33 cm apart, so that in the presence of any gradients computed salinities do not give the value at either position. Therefore, even if the sensor time constant curves were identical, this sampling position offset could produce a major error in the salinity so computed.

The above discussion indicates one possible partial solution for sensor time constant differences; increasing or decreasing the vertical separation between the sensors around a central value dictated by the sampling interval. However, it must be noted that this is only good for one lowering rate; at 1 m/s, the 1/3 of a second interval was equivalent to a 33 cm sensor separation - at 2 m/s it corresponds to 66 cm. Most oceanographers work from ships where, if the winch pays out cable at 1.5 m/s, the actual velocity of movement of the CTD fish may vary from 0.5 to 2.5 m/s according to the pitching and rolling of the vessel. Thus the appropriate separation for the sensors on the cage becomes problematical. Again, a "first-go" solution would be to determine the rate of pressure change with time from the data so collected, and to eliminate that data where the velocity of descent varied widely from 1.5 m/s, the undisturbed value.

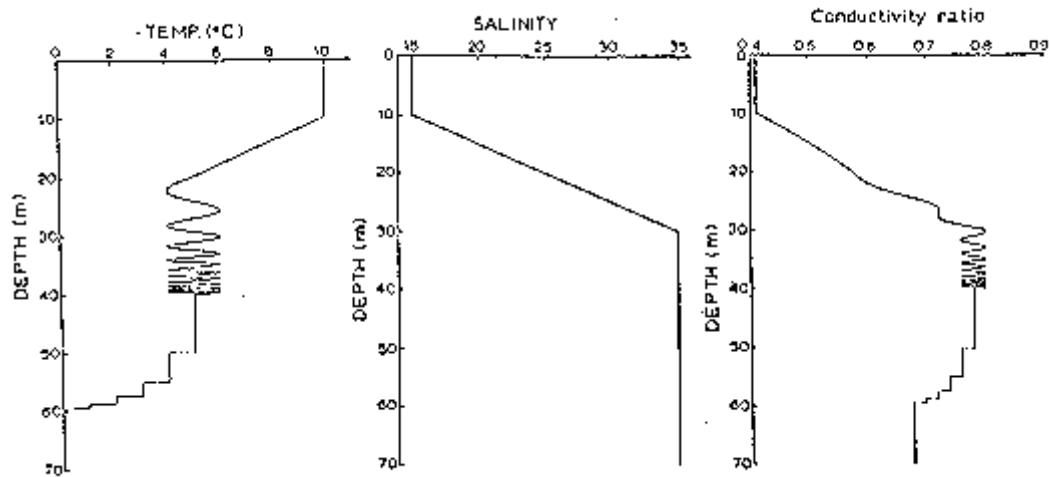

Figure A3: Artificial sea designed to demonstrate CTD response

A.4 COMPUTER SIMULATIONS OF CTD OBSERVATIONS

To appreciate the complex interrelationships between sensor time constants and sampling rate, we consider the response to synthetic temperature and salinity profiles containing features designed to illustrate their effects. (Figure A.3). They do not of course represent the real ocean.

For example, take values typical of one of the older CTD designs, in which a cell of length 20 cm is paired with a temperature sensor with time constant 200ms. These two sensors are at the same level ($z=0$ in Figure A.2), are being lowered at 1 m/s and scanned once per second with 1/3 second between the measurement of temperature and conductivity values. The standard ocean of figure A.3 is recorded as in figure A.4 by this instrument.

At the given lowering speed temperature and conductivity sensors are approximately 33 cm apart at the time their outputs are being sampled, and when there is a change of salinity with depth, between 10 and 20 m for example, a salinity offset results due to the combination of temperature and conductivity readings from the two different levels. The level ascribed to the salinity so calculated is that of the depth of the centre of the conductivity cell. As the depth increases from 20 to 40m the temperature sensor can no longer follow the sine wave so that as the frequency increases, an increasingly attenuated temperature signal results. In the end aliasing occurs, the high frequency is not resolved and a spurious slow change in temperature appears. In the same interval the salinity has errors up to nearly 2 units. Large errors also occur where step changes in temperature have been imposed, for example at 50m.

A first attempt to correct this state of affairs is to optimise the sensor positions in terms of their time constants, the lowering rate and the sampling frequency. It would be desirable that both sensors, when sampled, should have reached the same level of response to changing values in the ocean. As the two response curves are differently shaped, this can only be made to be true exactly at one point. Rather arbitrarily we will select the instant at which they have reached 63% of their final value, that is one time constant after the start of a step change. Suppose the sensors were sampled simultaneously. The distance moved by the probe during the time for the temperature sensor to reach 63% of its final value is W , where V is the lowering speed of the instrument. If, at this time, the conductivity sensor has reached the same percentage response approximately .55 of its length will be immersed in the new field so that we may write the equation (Figure A.3 defines h and L).

$$h = V\tau - 0.55L$$

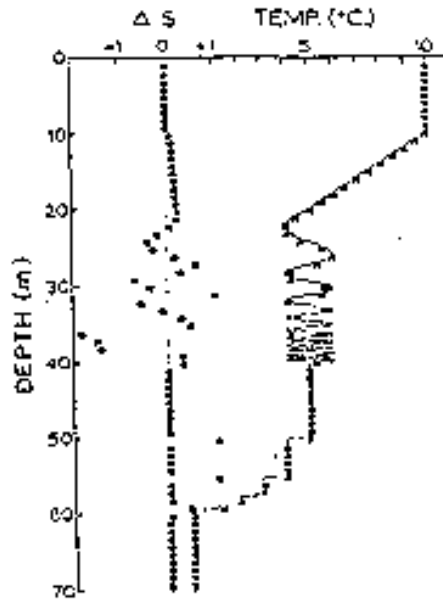

Figure A4: CTD Response - example 1. ΔS is "(observed - true)" salinity

However, sampling is not usually simultaneous but separated by a time interval δt and we will assume that this quantity is positive if the temperature sensor is sampled before conductivity. A further distance $V\delta t$ between the sensors must be introduced to compensate for this interval so that the total distance h from the bottom of the conductivity cell to the temperature sensor can be expressed as

$$h = V(\tau_1 + \delta t) - 0.55L \quad (\text{A.1})$$

This arrangement should match the response of the sensors at one point, the 63% value, but if it is possible to control V , the lowering speed, a match at a second point is possible. With the temperature sensor a distance h in front of the conductivity sensor there is a distance $h - V\delta t$ when only one sensor will have responded to the step change. Should sampling occur in this interval, major errors will result. Ideally it should be set to 0 which is equivalent to making both sensors match at the start of their response as well as at the 63% level. In this case, $h = V\delta t$ and V is defined by

$$V = 0.55L / \tau_1 \quad (\text{A.2})$$

Using the dimensions as for Figure A.4 as an example, this would give a lowering rate of about 55 cm/s.

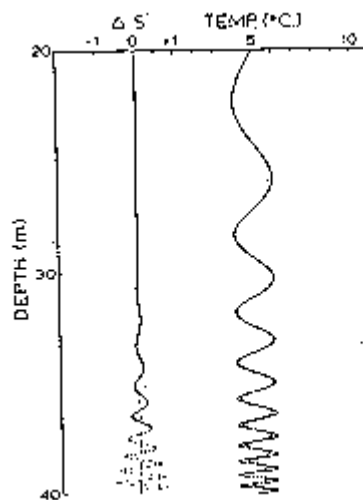

Figure A5: CTD Response-Example 2. "Fast" sampling system

Full details of the effect of these two corrections on the series are to be found in Perkin and Lewis 1982.

Consider now as an example of a fast sampling system a CTD instrument using the same sensors. In producing Figure A.5 we have taken 25 scans per second and applied equation A.1 to illustrate the performance of such a CTD in the depth interval 20-40 m in our standard ocean. Aliasing is no longer present, though the higher frequency portion of the sine wave becomes severely attenuated by the slow response of the temperature sensor. A considerable degree of salinity noise is present at these higher frequencies which, as mentioned above, is due to there being an interval $(h - V\delta t)$ where the temperature sensor will have started to respond to the change without the conductivity sensor having yet "felt" it. Figure A.6 shows the reduction in salinity noise brought about by applying both equations A.1 and A.2 to the same sensors (optimising both the drop rate and the separation of the sensors). As the lowering speed has dropped from 1 m/s to 55 cm/s the attenuation of the sine wave had been materially reduced due to the temperature changes being sensed at a lower frequency and the remaining salinity noise is now primarily due to the difference in shape between the temperature and the conductivity sensor response curves; we have forced them to agree at the 0 and 63% values. This represents just about the best it is possible to do with the instrument. If one wishes to resolve these high frequencies a faster time constant is required.

Another illustration of the difference in salinity readings obtained by varying the descent velocity is given in Figure A.7 which illustrates the response to the temperature discontinuity at 50 m in our standard ocean at various lowering rates. In going from the fastest to the slowest lowering rates $(h - V\delta t)$ goes from being positive to negative through zero at the optimum lowering rate of 55 cm/s fixed by equation A.2 and by the sensor separation. Thus at the fastest rates the temperature sensor starts its response before the conductivity sensor. At the lowest rates the opposite is true. The optimum constitutes a balance between the two effects minimising the salinity swing on either side of its correct constant value.

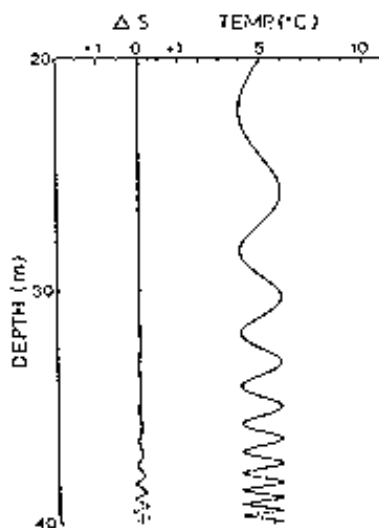

Figure A.6: CTD Response-Example 3. Same as Ex. 2 but optimised both for drop rate and sensor separation

A.5 EXAMPLES USING OBSERVATIONAL DATA

A.5.1 Calm conditions

The ideas developed in the preceding sections will now be applied to field data. Data acquired from ships frequently shows large fluctuations in the velocity of descent of the CTD but that acquired from the sea ice surface has usually been obtained at a constant velocity. The latter data is considered first as

a simple case. Figure A.8 shows sections from two CTD profiles from the Canadian Beaufort Sea taken in November/ December 1979. Both sets of curves show the temperature profile and the salinity as calculated for various values of TI as defined for use in equation A.1. The instrument was a Guildline Mk IV CTD with a thermometer time constant of 50 ms as given by the manufacturer ($\tau_1 \sim 25$ ms) and a conductivity cell length of 14 cm. From the pressure sensor readings it was determined that the instrument was lowered at a speed of $1.5\text{m/sec} \pm 10\%$. The sensors are mounted on the instrument so that $z=0$, i.e. 7 cm of the vertically mounted conductivity cell are on each side of the axis of the thermometer, a helical coil, which is horizontal during a vertical descent. The sensor outputs were sampled 25 times per second, and there was a delay of 5 ms between the sampling of the temperature and conductivity sensors ($\delta t = 5\text{ms}$).

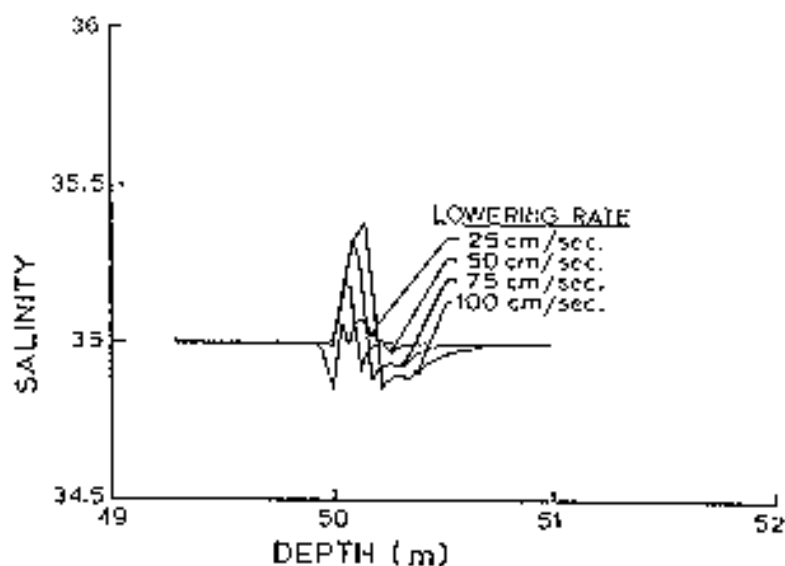

Figure A.7: CTD Response-Example 4. Effect of velocity variations

At this fast sampling rate it is not necessary to move the sensors with respect to each other as illustrated in figure A.2. The water mass properties have been taken every 6 cm during the descent and as neither sensor will respond significantly to fluctuating water properties at a smaller length scale, the time series of temperature and conductivity values may be considered smooth for interpolation purposes. The temperature and conductivity values to be combined to calculate a salinity are then selected from their time series so as to be separated by a time interval h/V , which is equivalent in this case to an actual physical separation of h . This procedure of "slipping" the time series is far more convenient as for a given δt one would have to alter the value of h for each new value of V , were it necessary to achieve the desired effect by actual sensor separation. For slowly sampled instruments, for example those having a second between samples as used to produce Figure A.5, an actual physical separation is necessary as the sensors could respond significantly to unresolved fluctuations in the water mass properties during that interval.

Figure A.8a shows the remarkable improvement obtained by applying equation A.1 each profile being characterised by a particular value of τ_1 . It is seen that $\tau_1 = 50\text{ms}$ produces by far the smoothest result and that quite a number of "significant features" in the salinity profile have been eliminated by this processing technique. In an environment with a smoothly changing salinity/depth profile, major temperature fluctuations, combined with conductivities taken at the "wrong time" have produced artificial salinity changes. It is important to realise that these spurious features have been generated solely by allowing a variation of τ_1 from 0 to 100 ms. Figure A.8b illustrates the well-known phenomenon of "spiking" at sudden changes in the slope of a temperature or conductivity curve, and its elimination by proper processing.

The question does arise of how the curve for $\tau_1 = 50$ ms is selected as being "best". It is noted for example that the feature at -the 65 db pressure level on Figure A.8 has very noticeably reversed its direction to turn from a salinity reduction to a salinity increase as the value of τ_1 is increased, and is flattened out at $\tau_1 = 50$ ms. On figure A.8b the spikes of temperature and salinity at about 38 db are certainly associated with each other and the use of $\tau_1 = 50$ ms has resulted in the elimination of the salinity spike. Nevertheless, some subjectivity still exists in the argument, which is one of the reasons why the criteria were applied to a known computer-generated ocean in earlier sections. The next logical step would be to apply equation A.2 to the $\tau_1 = 50$ ms curves of Figure A.8 to see if a further improvement to this data would result. On putting appropriate values into equation A.2 it is found that an optimum value for the descent velocity would be 1.54 m/s so that the difference between this ideal rate and that actually used in practice is too small to make any significant difference in the result.

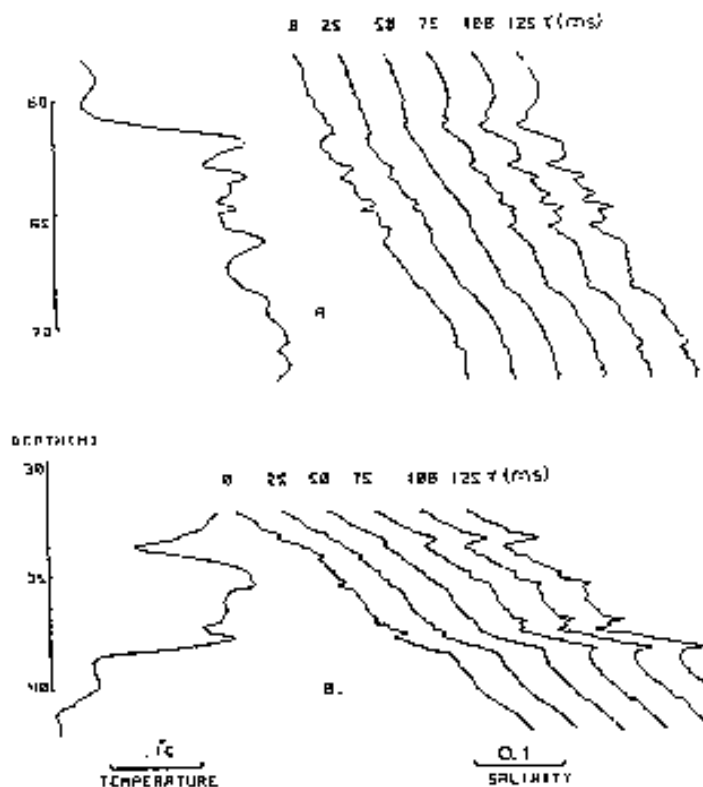

Figure A.8: The processing of two sections of data from the Beaufort Sea. In both cases the salinity is increasing steadily with depth but temperature, the left hand curve in both cases, has considerable structure. The set of six curves on the right are labelled with the values of τ_1 taken for the computation of salinity using equation AA to move the temperature and conductivity ratio time series in relation to each other. It is seen that most of the salinity structure is removed by taking $\tau_1 = 50$ ms, which is the manufacturer's given value. It is interesting to note the spurious "intrusive layers" created by taking other values.

In shipborne use, where the velocity of descent of the probe may go through large and sometimes violent fluctuation, including reversal, this simple approach cannot be expected to compensate for the complicated fluid dynamical processes which result. It is best to specify a range of lowering rates and data taken outside these limits can be excluded from processing or flagged to indicate their lower expected accuracy. The remaining data can be processed as described above.

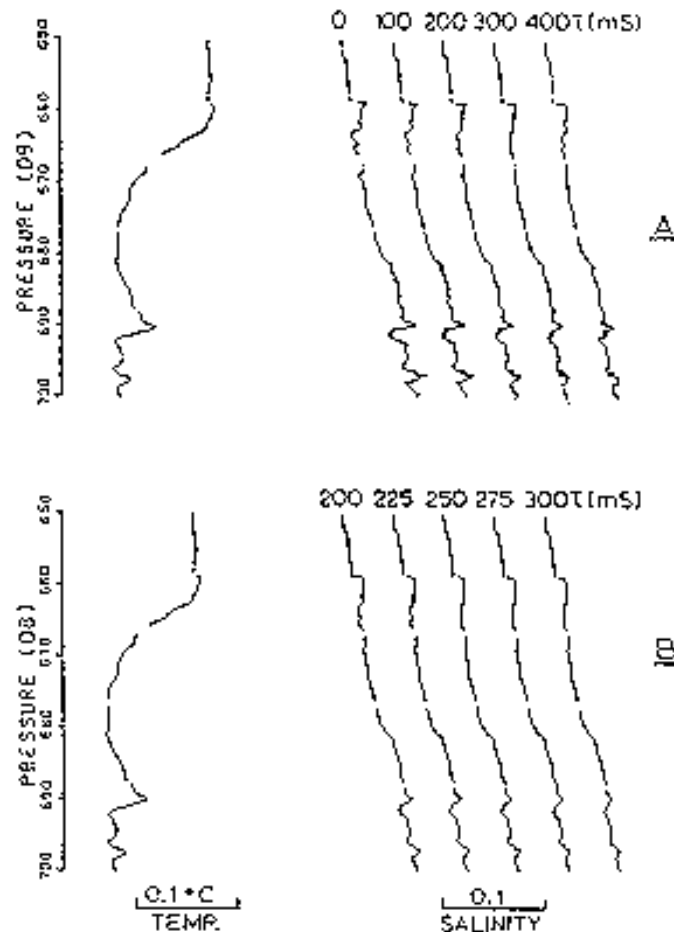

Figure A.9: Processing of section of data collected by I.O.S., Wormley, U.K. The velocity of descent varied from 12 cm/sec to 175 cm/sec during this record. The range $200\text{ms} < \tau_1 < 300\text{ms}$ is selected from A as optimum for adjustments based on equation A. 1 of text, and then applied to produce a filter for the conductivity sensor data with the result shown in B. Temperature profiles are given on the left. All values taken when the probe was moving at less than 50 cm/sec have been eliminated from the record.

A.5.2 Moderate and rough conditions

This was done for two stations taken during Discovery Cruise 81 by the Institute of Oceanographic Sciences, Wormley, U.K. in January 1980. The instrument used was a Neil Brown CTD equipped with a 200 to 250 ms time constant temperature sensor. The conductivity sensor, whose effective length is about 3 cm, responds much more rapidly than the temperature sensor and this difference must be reconciled in data processing. The velocity of descent of the probe varied between 12 cm/s and 175 cm/s as the data shown in figure A.9 was collected. Figure A.9 a shows the results obtained by application of equation A.I. The features at 665 and 690 db pressure are responding to the changes in T, and appear to reach a minimum at between 250 to 300 ms. Figure A.9 b shows the result of filtering the conductivity so as to artificially increase time constant to match that given by equation A.2 (see also chapter 5 case 6). As is seen from the equation the filtering required is a function of velocity of descent so that the filter is continuously varying. Note the general loss of detail and the smoothing of sharp features such as the step at 660 db pressure as this artificial time constant is increased. For this reason, it is difficult to make an objective assessment of the quality of the profiles but $\tau_1 = 275$ ms appears to be close to the optimum.

Figures A.10 a and b show the same procedure applied to a profile with a more violently changing lowering rate (2.5 m/s to -0.4 m/s in 4 m) in a section of water with greater temperature gradients. In A.10a, many of the high frequency salinity features seem to arise in the presence of high temperature gradients independent of lowering rate variations. These are mainly due to the time constant mismatch and are largely damped out in the second stage of processing, Figure A.10b. Some features such as the spike just about 670 db arise from negative lowering rates (in the presence of a temperature gradient) and are deleted by ignoring all data taken below a 0.50 m/s lowering rate which has been done in Figure A.10b, where the varying filter of equation A.2 is used.

Features of questionable validity such as at 645 db still survive. Nevertheless, the $\tau_1=275$ ms curve still seems to produce the best result. This serves to demonstrate the limitations of this kind of processing which produces an optimum profile to be viewed critically before being accepted. In practice it is generally agreed that all CTD data taken with negative portion to the probe velocity cycle is of little use. Water is dragged along by the probe which is engulfed by this wake as it rises and in these circumstances it appears impossible to place bounds on the precision or accuracy of the data. In this case, the effect of the processing scheme on the salinity profile of Figure A.10 has been to change the computed salinity (10 m average) by up to .006 depending on the temperature gradient. Effects of this size can have a large effect on stability calculations.

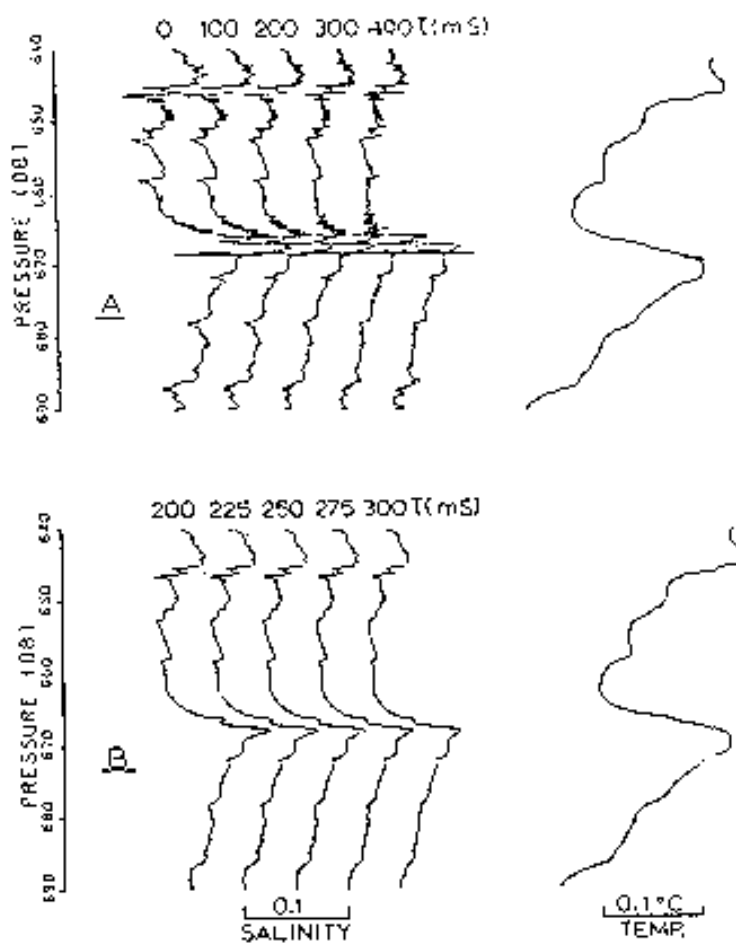

Figure A.10: a and b Processing of I.O. S., Wormley data having negative probe lowering rates due to violent ship movement. a) shows all the data and the application of Equation A1 allowing selection of τ_1 within range 200 to 300 ms. Feature at 669 db caused by velocity reversal. b) shows application of Equation A.2 and elimination of all values taken when probe was moving at less than 50 cm/sec. Temperature profiles are given on the right.

SECTION 2.1 APPENDIX B: DIGITAL LOW-PASS FILTERS

B.1

This Appendix contains selected digital low pass filters and their characteristics which may be useful for smoothing CTD data series. Characteristics of each filter are given to aid the user in choosing a particular filter for his data.

Filters are applied using the following equation:

$$X'(n) = W(0)X(n) + \sum_{k=1}^{k=K} W(k)[X(n - k) + X(n + k)] \tag{B.1}$$

Where $X(n)$ is the original, equally spaced data series, $W(k)$ are the K weights of the filter, and $X'(n)$ is the new data series. Note that $2k + 1$ input data values are combined to make each filtered data value. These filters are symmetric to prevent phase shifts and K data values will be lost at the beginning and at the end of the filtered data series.

Two aspects need to be considered when choosing a digital filter: the frequency response and the convenience of application of the filter.

The frequency response of symmetric filters is computed as:

$$Gain(f) = W(0) + 2 \sum_{k=1}^{k=K} W(k) \cos(2\pi f k)$$

with f being in units of cycles per data interval. The response curves for the attached figures were computed at 128 equally spaced frequencies from 0 to 0.5 cycles per data interval.

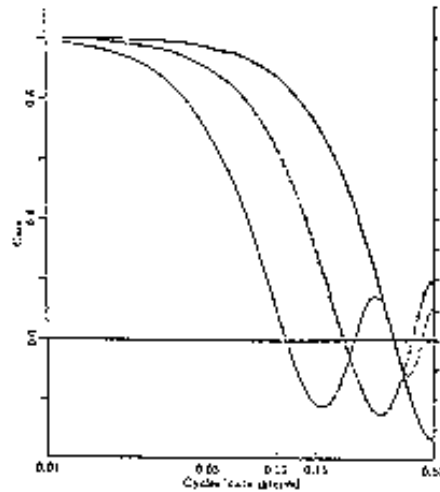

Running Mean 3 points.	—————
Stop band starts (1 % gain)	0.328
Max overshoot	-33.3% at 0.500
Running Mean 5 points	—————
Stop band starts (1 % gain)	0.195
Max overshoot	-25.0% at 0.289
Running Mean 9 points	—————
Stop band starts (1 % gain)	0.109
Max overshoot	-22.7% at 0.160

Figure B.1: Cosine response for several running mean filters

B.2 RUNNING MEAN FILTERS

Running mean filters are filters whose weights are all equal. The responses of 2-, 3-, and 5-weight (3, 5, and 9 data points used respectively) running mean filters are shown in figure B.]. In this figure it can be noted that all input frequencies are attenuated and that large negative response ripples occur in the stop band. These negative ripples are undesirable. They indicate a phase shift of 180° (maxima become minima and vice-versa).

As a general rule, running mean filters are not useful even though easy to apply because of the poorly behaved response functions.

B.3 NORMAL AND BINOMIAL FILTERS

Normal filters are those whose weights are proportional to a Gaussian or normal distribution as indicated in table B.1. The start of the stop band (0.01 gain) is determined by σ . The larger the value of σ , the lower the frequency of the stop band. Binomial filters are those whose weights are proportional to the coefficients of a binomial expansion. The simplest binomial filter, $K = 2$, has weights of $W(0) = 0.5$ and $W(1) = 0.25$ and is called the elementary binomial filter (Harming). Both the normal and binomial filters are well behaved in their response functions (figure B.2) as they have no negative gains. However, all low frequencies are attenuated and the cutoff frequency band is very broad. With the exception of the elementary binomial filter (Harming) which is well behaved and easy to apply, better response functions (sharper cutoffs) can be achieved with designed digital filters.

Filter	Weights	Response
M Point Equally Weighted Running Mean	$w(k) = \begin{cases} 1/M & k=0,K \\ 0 & k > K \end{cases}$	$\frac{\sin(\pi f m)}{\pi f m}$
M Point Equally Weighted Running Mean Applied twice		$\left[\frac{\sin(\pi f m)}{\pi f m} \right]^2$
Normal Curve Smoothing	$W(k) = \frac{\exp(-k \sigma / 2)}{\sqrt{2 \pi \sigma}}$	$\exp(-2\pi^2 \sigma^2 f^2)$
Elementary Binomial Smoothing	$w(0) = 0.5$ $w(1) = 0.25$	$\cos^2(\pi f)$
Designed Filters Filter #4	see Figures B.2 to B.9	(not analytical)

Table B.1: Weights and responses of some filters

B.4 DESIGNED FILTERS

Digital filters with specified response functions can be designed using Least Squares techniques (Millard et al. 1980). The number of degrees of freedom (number of weights) must be greater than the number of constraints imposed upon the shape of the response function. The values of the individual weights are computed such that the undesirable overshoots or ripples (Gibbs phenomena) in the pass and stop bands of the response are minimised. Figure B.2 through B.9 contain 8 such designed filters which have a variety of response functions. This selection of response functions is probably adequate for normal processing of CTD data. Some of these filters are designed to lower the frequency cutoff (frequency of 0.99 gain). Others are designed for less overshoot. As the number of weights increases, it is possible to have both a low frequency cutoff and minimum overshoot (figure B.7). The cost of this response is an increased loss of data at the beginning and end of the series and longer computation times. The response function of the filters can be shifted to lower frequencies by applying the weights

to every other or every third input data value. The frequency response is then shifted by a factor of 1/3 or 1/3 respectively:

$$X'(N) = \omega(0)X(N) + \sum_{k=1}^{k=K} W(k)[X(n - jk) + X(n + jk)]$$

$$Gain(f) = W(0) + 2 \sum_{k=1}^{k=K} W(k) \cos(2\pi f k / j)$$

where j=2 or 3 respectively depending on the shift desired. However, the highest frequencies will not be attenuated unless filtered separately. For more detailed discussion on filter design and usage the reader is referred to Gold and Rader (1969) and Holloway (1958).

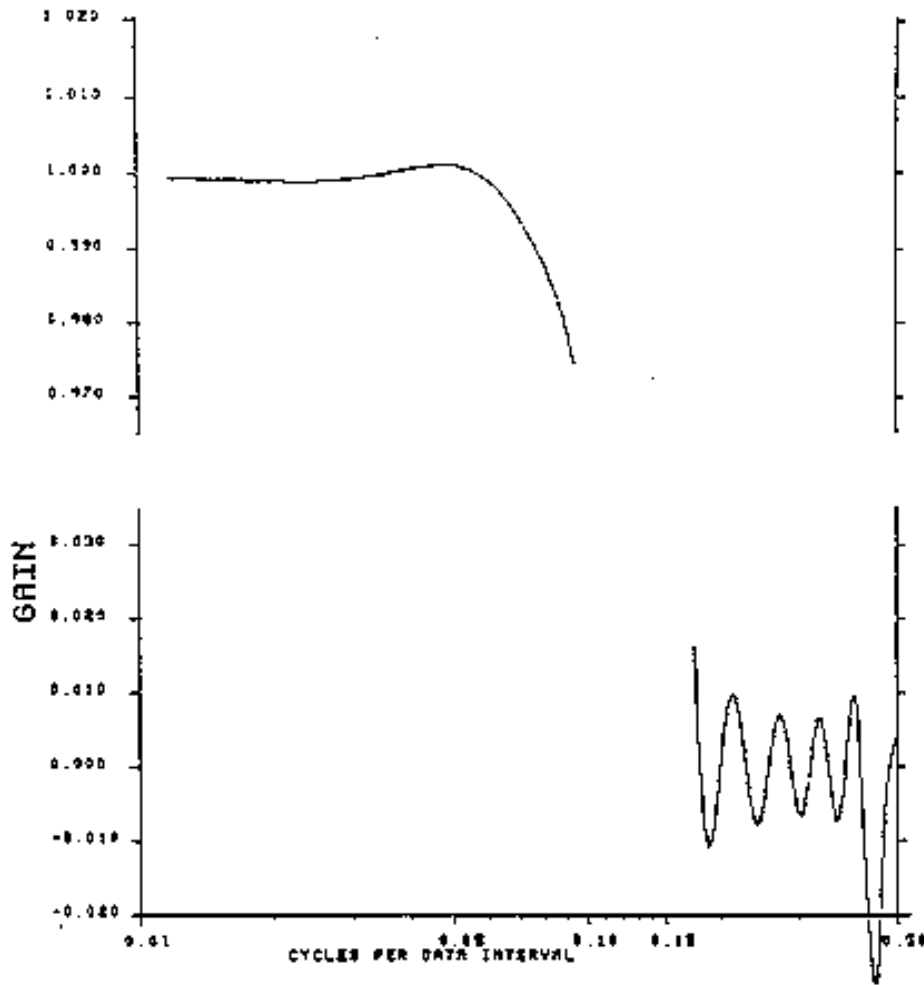

Pass band ends		(99% gain) 0.074		Stop band starts		(1% gain) 0.176	
Max overshoot		0.20% at 0.047		Max overshoot		-2.9% at 0.445	
W ₀	0.2768802	W ₁	0.2442462	W ₂	0.1496963	W ₃	0.0488144
W ₄	-0.0260295	W ₅	0.0493596	W ₆	-0.0319492	W ₇	-0.0036896
W ₈	0.0190385	W ₉	0.0162940	W ₁₀	0.0082729	W ₁₁	-0.0066539
W ₁₂	-0.0074337	W ₁₃	0.0052996	W ₁₄	-0.0009787	W ₁₅	0.0046339

Figure B2: Cosine response for filter #1 of 16 weights

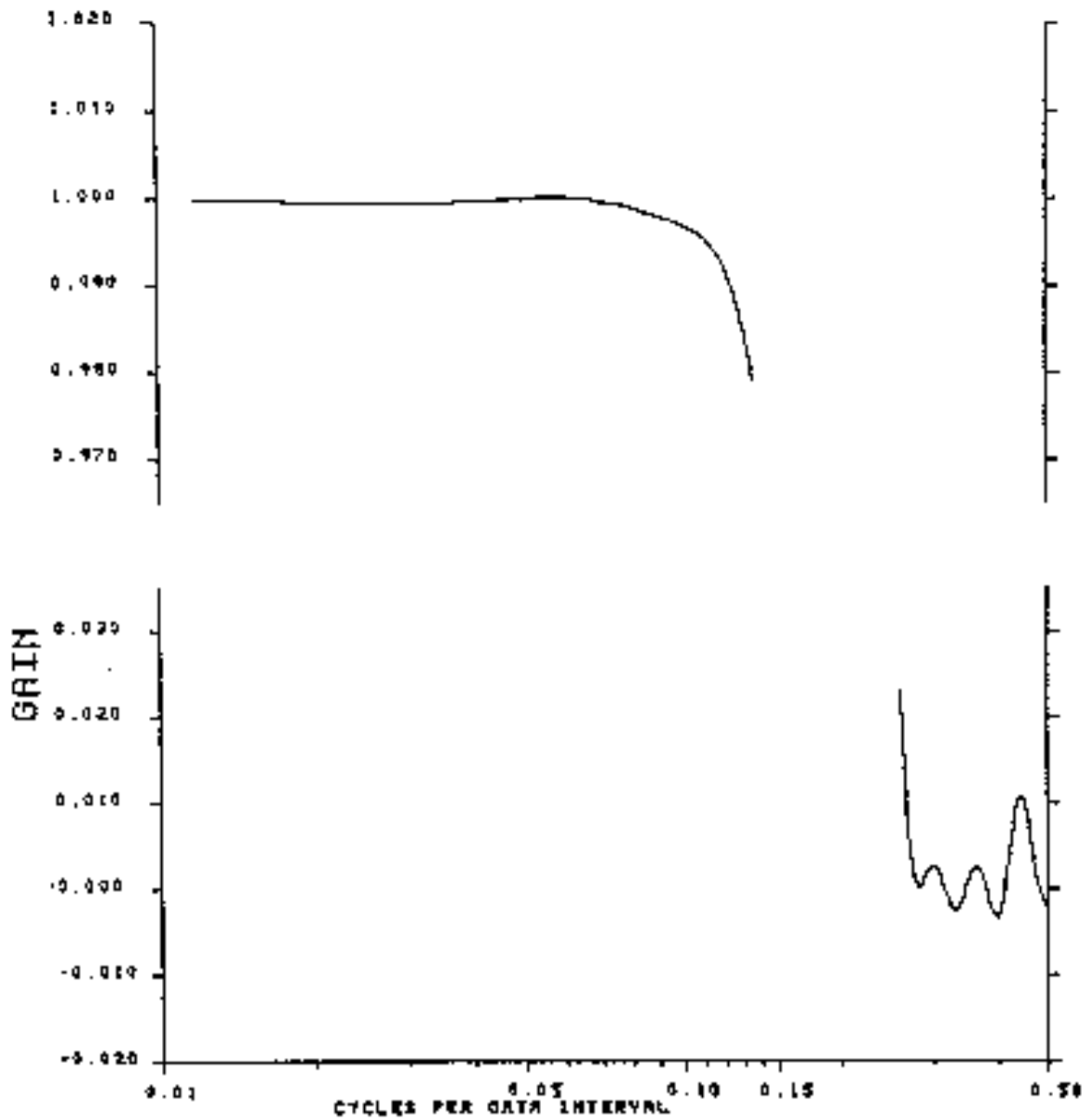

Pass band ends		(99% gain) 0.121		Stop band starts		(1% gain) 0.266	
Max overshoot		0.20% at 0.059		Max overshoot		1.06% at 0.445	
W ₀	0.4190081	W ₁	0.3013399	W ₂	0.0722501	W ₃	-0.0658397
W ₄	-0.0488515	W ₅	0.0146972	W ₆	0.0268943	W ₇	-0.0004853
W ₈	-0.0135485	W ₉	-0.0017893	W ₁₀	0.0049278	W ₁₁	-0.0024629
W ₁₂	-0.0029224	W ₁₃	-0.0008220	W ₁₄	0.0012218		

Figure B3: Cosine response for filter #2 of 15 weights

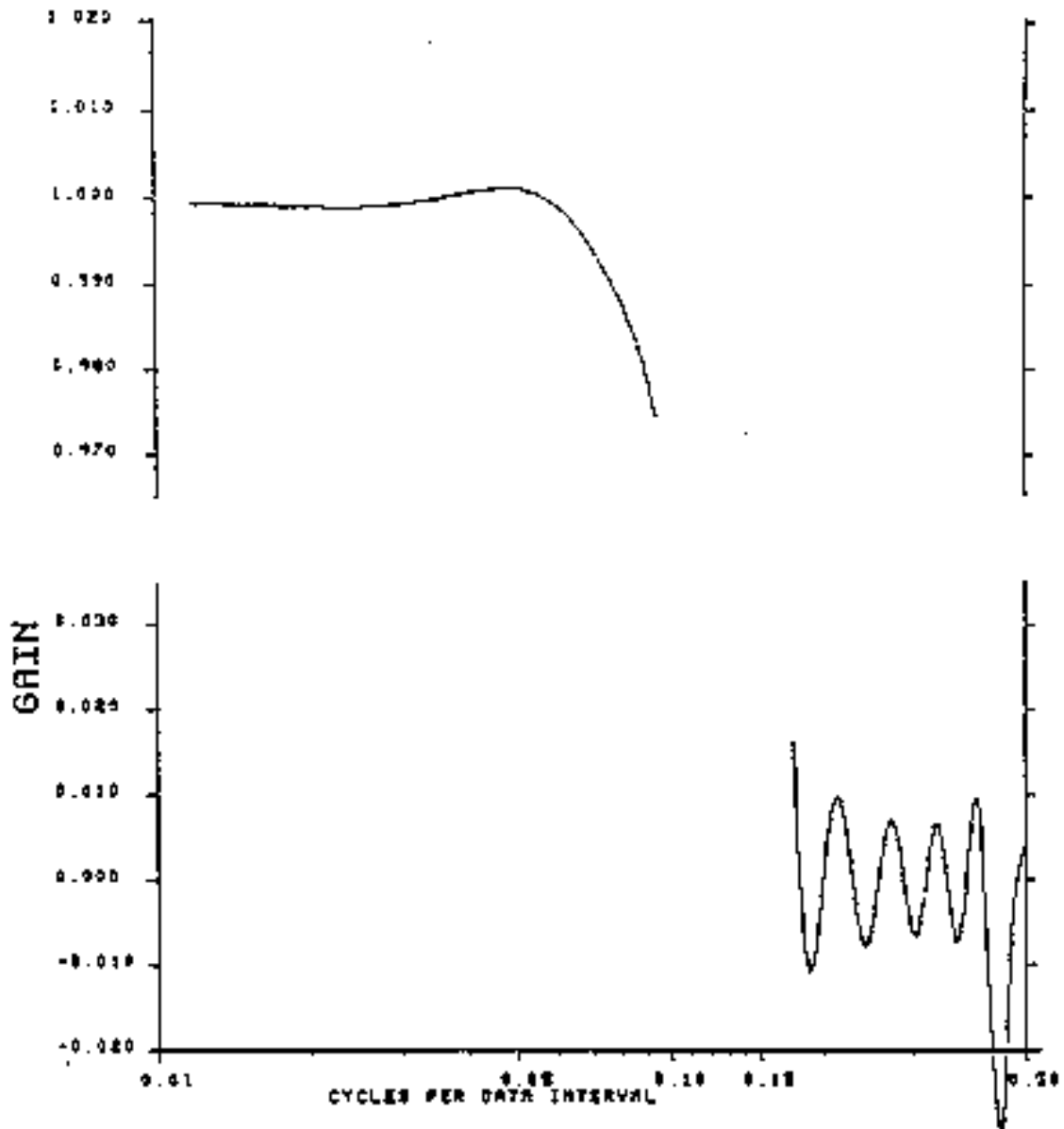

Pass band ends		(99% gain) 0.156		Stop band starts		(1% gain) 0.324	
Max overshoot		0.20% at 0.121		Max overshoot		0.40% at 0.352	
W ₀	0.5010932	W ₁	0.3085158	W ₂	-0.0010790	W ₃	-0.0803063
W ₄	0.0031749	W ₅	0.0272290	W ₆	-0.0043802	W ₇	-0.0054385
W ₈	0.0017376						

Figure B4: Cosine response for filter #3 of 9 weights

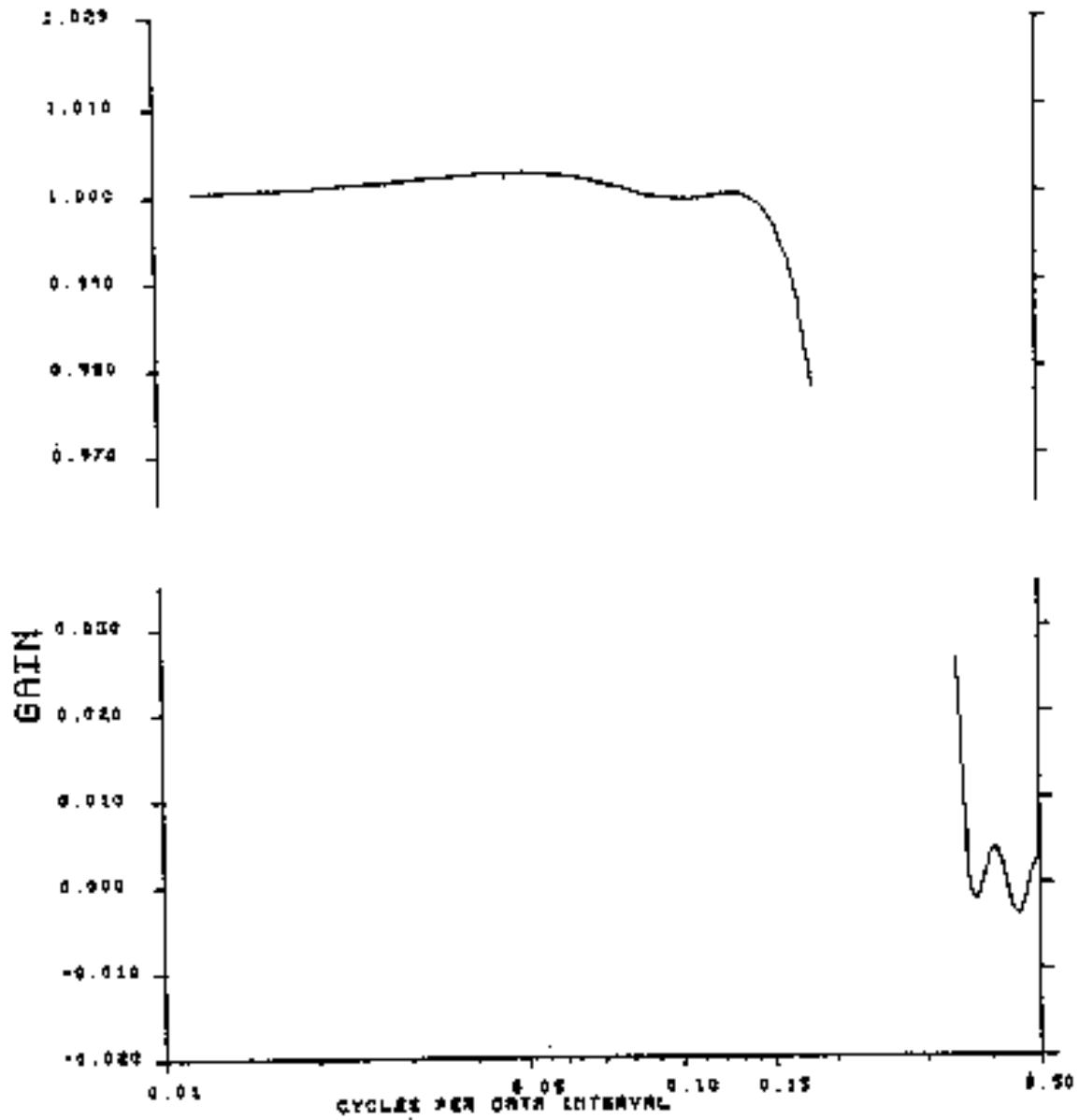

Pass band ends		(99% gain) 0.164		Stop band starts		(1% gain) 0.355	
Max overshoot		0.25% at 0.047		Max overshoot		0.40% at 0.406	
W ₀	0.5584561	W ₁	0.3029849	W ₂	-0.0511726	W ₃	-0.0654825
W ₄	0.0348655	W ₅	0.0129523	W ₆	-0.0172377	W ₇	0.0021056
W ₈	0.0051739	W ₉	-0.0033275				

Figure B.5: Cosine response for filter #4 of 10 weights

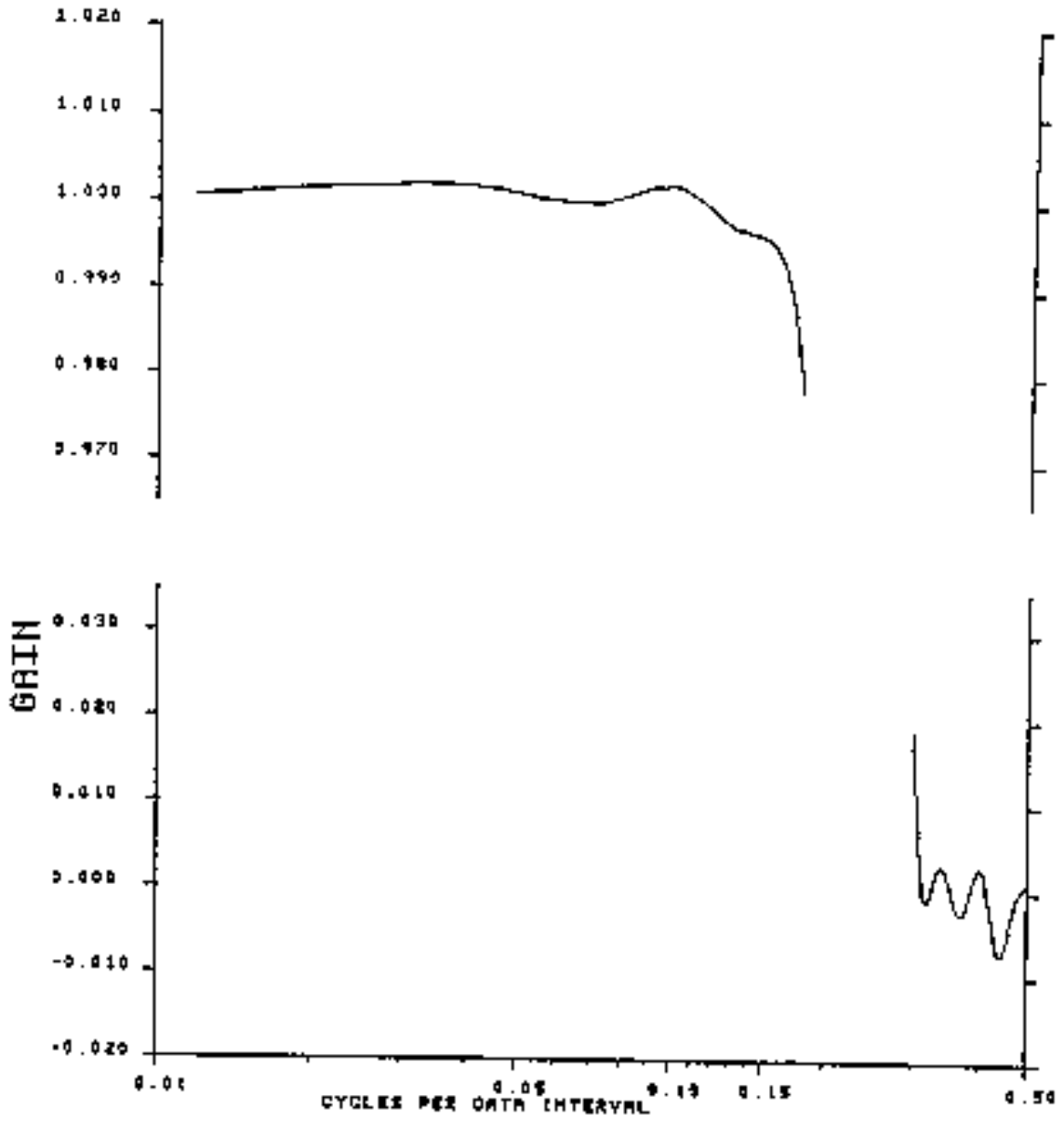

Pass band ends		(99% gain) 0.168		Stop band starts		(1% gain) 0.301	
Max overshoot		0.20% at 0.031		Max overshoot		-0.73% at 0.441	
W ₀	0.4991365	W ₁	0.3133391	W ₂	-0.0005088	W ₃	-0.0903099
W ₄	0.0021894	W ₅	0.0415346	W ₆	-0.0037534	W ₇	-0.0204751
W ₈	0.0047479	W ₉	0.0088399	W ₁₀	-0.0034032	W ₁₁	-0.0041089
W ₁₂	0.0031772	W ₁₃	0.0009740	W ₁₄	-0.0018111		

Figure B.6: Cosine response for filter #5 of 15 weights

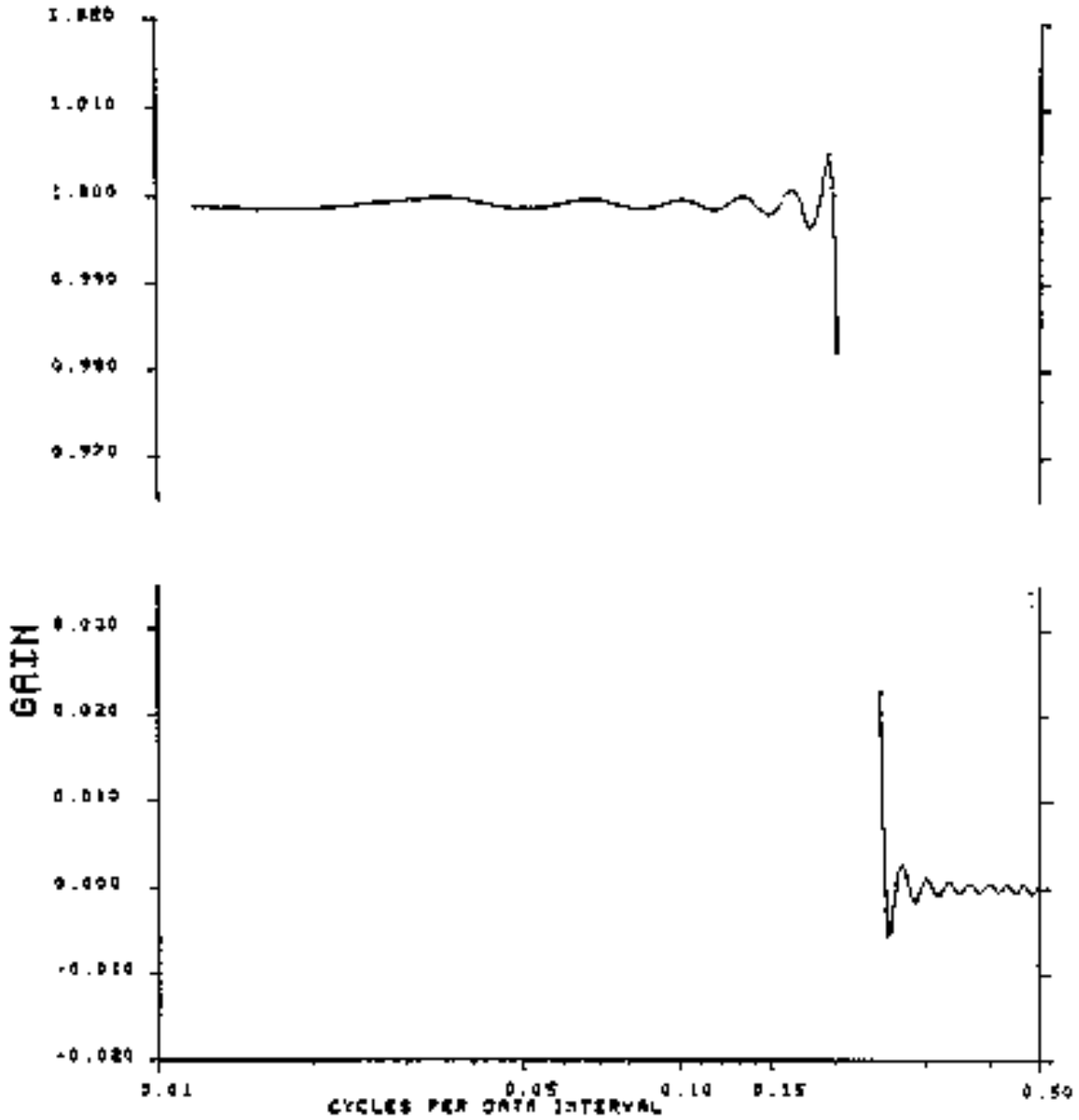

Pass band ends		(99% gain) 0.199		Stop band starts		(1% gain) 0.246	
Max overshoot		0.50% at 0.195		Max overshoot		-0.56% at 0.254	
W ₀	0.4495917	W ₁	0.3133727	W ₂	0.0486798	W ₃	-0.0924791
W ₄	-0.0450054	W ₅	0.0424056	W ₆	0.0393836	W ₇	-0.0183585
W ₈	-0.0324500	W ₉	0.0045547	W ₁₀	0.0249799	W ₁₁	0.0033714
W ₁₂	-0.0176984	W ₁₃	-0.0073033	W ₁₄	0.0112562	W ₁₅	0.0084840
W ₁₆	-0.0060543	W ₁₇	-0.0078532	W ₁₈	0.0023246	W ₁₉	0.0062613
W ₂₀	0.0000078	W ₂₁	~0.0043260	W ₂₂	-0.0010949	W ₂₃	0.002566,4
W ₂₄	0.0013402	W ₂₅	-0.0012029	W ₂₆	-0.0009825	W ₂₇	0.0003937
W ₂₈	0.0005411	W ₂₉	-0.0000384	W ₃₀	0.0001281		

Figure B.7: Cosine function for filter #6 of 31 weights

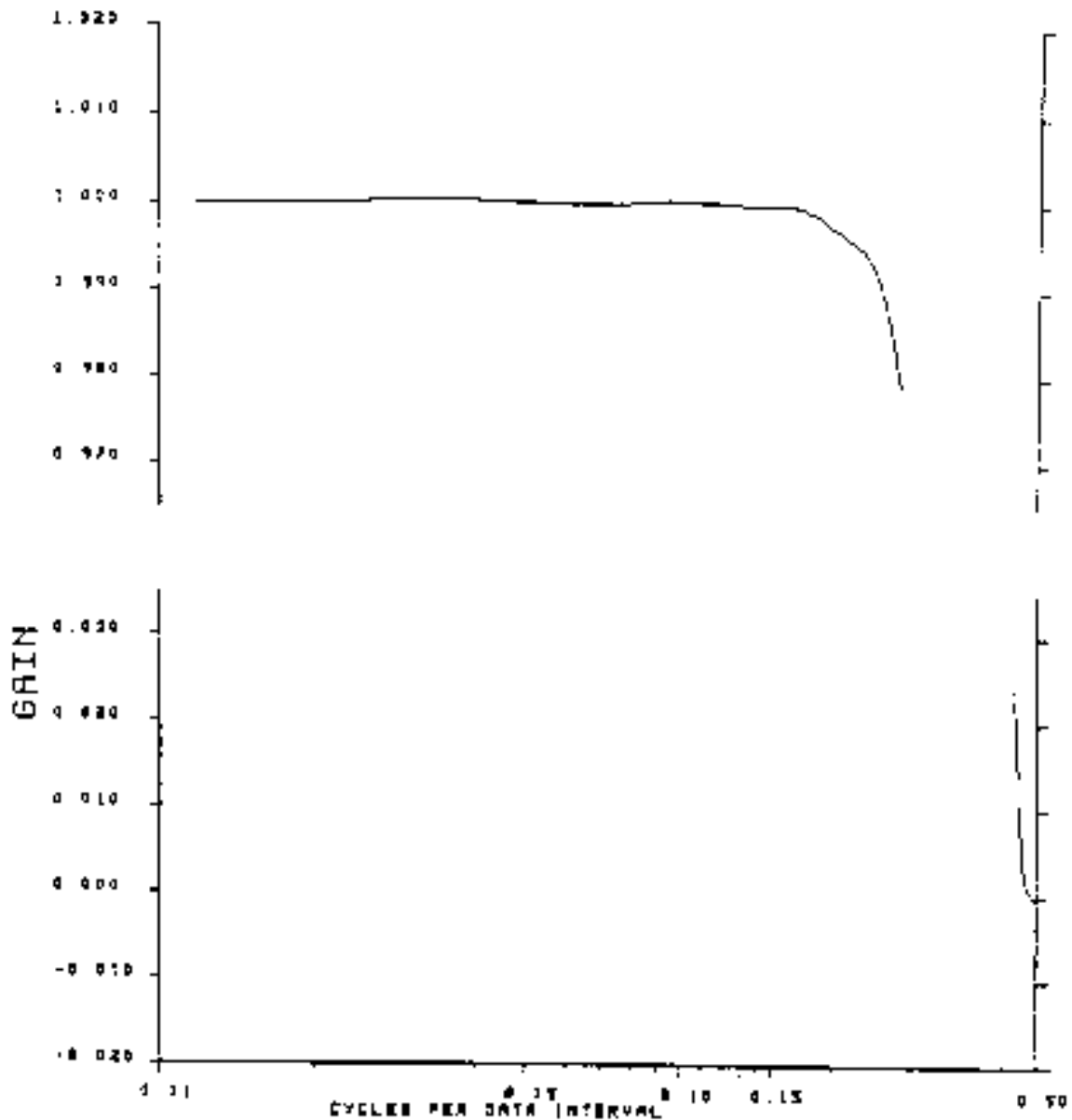

Pass band ends				(99% gain) 0.246				Stop band starts				(1% gain) 0.461			
Max overshoot				0.04% at 0.102				Max overshoot				-0.04% at 0.500			
W ₀	0.7535998	W ₁	0.2130059	W ₂	-0.1352064	W ₃	0.0577258	W ₄	-0.0084005	W ₅	0.0112546	W ₆	0.0130043	W ₇	-0.0086977
W ₈	0.0044511	W ₉	-0.0015515	W ₁₀	-0.0000139	W ₁₁	0.0005426	W ₁₂	-0.0004948	W ₁₃	0.0003637	W ₁₄	-0.0002439		

Figure B.8: Cosine function for filter #7 of 15 weights

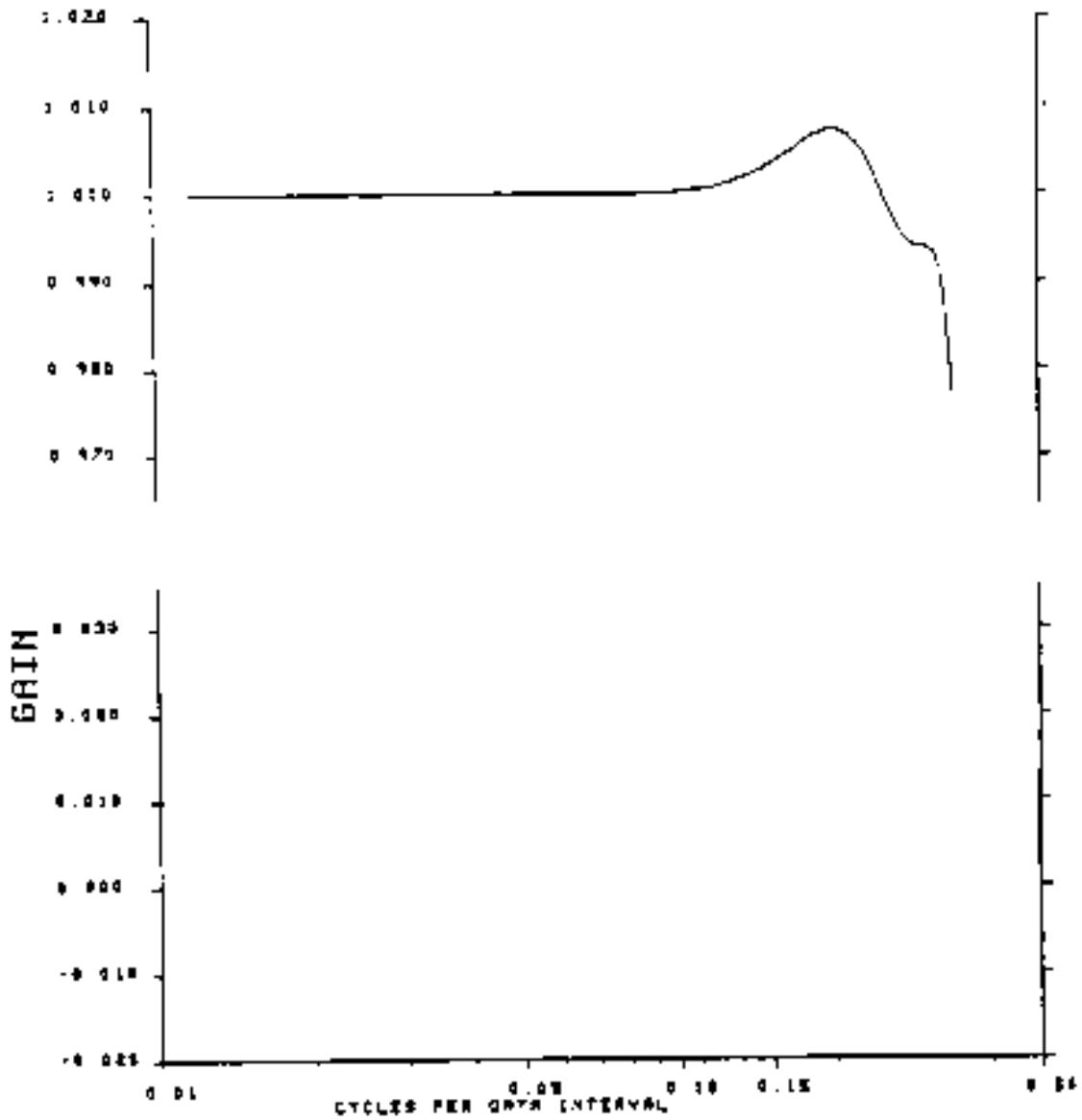

Pass band ends		(99% gain) 0.324		Stop band starts		(1% gain) 0.488	
Max overshoot		0.72% at 0.199		Max overshoot		0.10% at 0.500	
W ₀	0.8483344	W ₁	0.1428571	W ₂	-0.1161113	W ₂	0.080253
W ₄	-0.0490476	W ₅	0.0252545	W ₆	-0.0087691	W ₇	0.001395

Figure B.9: cosine response for filter #8 of 8 weights

SECTION 2.1 APPENDIX C GF3 STANDARD SUBSET FOR CTDS

The GF3 Format has been adopted by the International Committee for Oceanographic Data Exchange and is now in regular use by data centres and some institutions for exchange, and in several cases, for archival of a wide variety of data types.

Though originally designed for sequential use on tape, it is now finding wider application. Its most important qualities lie in its definition records, which allow for the description of the format and of the variables present in the header and data records. The possibility of placing data in headers allows one to place calibration data sets or other data relevant to entire series there. Plain language records give unlimited scope for a description of the series. The records are all 1920 bytes long. By the use of scaling factors defined for each variable in the definition record it is easy, within the confines of an ASCII format, to closely pack the records. The header and definition records have mostly fixed format fields.

For commonly used data sets such as those from CTDS, standard subsets of GF3 have been adopted. Legibility with simple dump programs rather than close packing is the criterion used but if this is not acceptable then all that need to be changed are the scaling factors and format description in the definition record.

The following pages show such a dump for a CTD data set together with an annotation of the definition records. A full description of the fields in the header records that are not immediately apparent can be found in Manuals and Guides No. 17, vol. 2, Technical Description of the GF3 Format (UNESCO, 1987).

RECORD 3 SERIES HEADER DEFINITION RECORD.

1 2 3 4 5 6 7

1234567890123456789012345678901234567890123456789012345678901234567890

34	0	61	(38(I5,1x,I5,1x,I5,1x,I5,1x,I5, 1x, 15, 5x)				001
3							002
3							003
3	PRES7PRD	SEA PRESSURE(CTD)	DBAR.I	5-94	0.1	0	004
3	TEMP7STD	SEA TEMPERATURE(CTD)	DEG.CI	5-94	0.001	0	005
3	PSAL7PRD	PRAC.SALINITY(CTD)	1	5-94	0.001	0	006
3	PRES7RTD	SEA PRESSURE(THERM)	DBAR.I	5-94	0.1	0	007
3	TEMP7RTD	SEA TEMPERATURE(THERM)	DEG.CI	5-94	0.001	0	008
3	PSAL7BSD	RAC.SALINITY(BOTTLE)	1	5-94	0.001	0	009
3							010
3							011
3							012
3							013
3							014
3							015
3							016
3							017
3							018
3							019
3							020
3							021
3							022
3							023
3							024

RECORD 4 DATA CYCLE DEFINITION RECORD.

1 2 3 4 5 6 7 8

123456789012345678901231567890123456789012315678901234567890

45	0	6P(60x,92(15,A1,IS,A1,I5,A1,2x))					001
4							002
4							003
4	PRES7PRD	SEA PRESSURE DB=10kPASCAL	1	5-94	0.1	0	001
4	FFFF7AAN	QUAL.FLAG PRESSURE	A	1			005
4	TEMP7STD	SEA TEMPERATURE	DEG.C	1	5-94	0.001	006
4	FFFF7AAN	QUAL.FLAG TEMPERATURE	A	1			007
A	PSAL7PRD	PRACTICAL SALINITY	1	5-94		0.001	008
4	FFFF7AAN	QUAL.FLAG SALINITY	A	1			009
A							010
4							011
4							012
4							013
4							014
4							015
4							016
4							017
4							018
4							019
4							020
4							021
4							022
4							023
4							024

END OF FILE.

CONTENTS OF DATA FILES

DATA FILE 1

RECORD 1 FILE HEADER RECORD.

	1	2	3	4	5	6	7	8	
12345678901234567890123456789012315678901234567890123156789012345678901234567890									
50	749010	UNITED KINGDOM			INST.OCEANOLOG.SCI. 851107122625	CTD DEMO 2			001
531 SHIP	474-74	DISC R.R.S. DISCOVERY			CRUISE117	19810119		19810212	002
5									003
5198101251132	198102100443		999999 999999			999999999999	0	5600	004
523700	N 2100	W4400	N 1300	W23A	A	CRI17-CTD	1	0	0005
5									006
5									007
5									008
5									009
5									010
5									011
5									012
5									013
5									014
5									015
5									016
5									017
5									018
5									019
5									020
5									021
5									022
5									023
5									024

RECORD 2 PLAIN LANGUAGE RECORD.

	1	2	3	4	5	6	7	8	
123A567890123456189012345678901234567890123456789012345678901234567890									
00	**DOCUMENTATION FOR CTD DATA FROM DISCOVERY CRUISE 117****								001
0									002
0	*FULL DOCUMENTATION AVAILABLE IN SAUNDERS P.M. (1981), CTD DATA								003
0	OBTAINED DURING DISCOVERY CRUISE 117, IOS DATA REPORT NO 26 - SUMMARY								004
0	GIVEN BELOW								005
0									006
0	**INSTRUMENTATION/DATA COLLECTION-								007
0	NEIL BROWN CTD PROFILER (SEE BROWN, N AND G. MORRISON (1978), WHOI/								008
0	BROWN CTD MICROPROFILER, WHOI-78-23) HELD IN FRAME WITH GENERAL								009
0	OCEANICS MULTISAMPLER WITH 12 NISKIN BOTTLES. DATA COMPUTER LOGGED ON								010
0	BOARD AT NEAR 30 SAMPLFS/SECOND WITH RESOLUTIONS OF 0.5 MILLIDEGREES								011
0	C_ 0.1 DECIBARS AND 0.001 MILLIMHOS/CM. CTD PROFILE OBTAINED ON								012
0	UNINTERRUPTED DOWN LOWERING AT SPEEDS BETWEEN 0.5 AND 1.0 M/SEC.								013
0	BOTTLE SAMPLES AND REVERSING THERMOMETER MEASUREMENTS (PROTECTED AND								014
0	UNPROTECTED) COLLECTED ON ASCENT AT SELECTED LEVELS WITH INSTRUMENT								015
0	HELD FOR 5 MINUTES TO ALLOW THERMOMETERS TO COME TO EQUILIBRIUM.								016
0	SIMULTANEOUS CTD PRESSURE AND TEMPERATURE WERE ALSO RECORDED AT EACH								017
0	BOTTLE SAMPLE LEVEL ON ASCENT. SEAWATER SAMPLES ANALYSED ON BOARD								018
0	WITH GUIDLINE AUTOLAB SALINOMETER - THREE SAMPLES BEING DRAWN OFF								019
0	EACH BOTTLE. REVERSING THERMOMETERS CALIBRATED BEFORE AND AFTER								020
0	CRUISE - NO SIGNIFICANT CHANGE DETECTED. CLOSE TO SEA FLOOR THE								021
0	HEIGHT ABOVE FLOOR WAS MONITORED USING A FREE RUNNING 10KHZ PINGER								022
0	ATTACHED ALONGSIDE THE CTD AND MULTISAMPLER.								023
0									024

RECORD

PLAIN LANGUAGE RECORD.

	1	2	3	4	5	6	7	8
	1234567890123456789012345678901234567890123456789012345678901234567890							
00	TWO CTD UNITS WERE EMPLOYED - THE FIRST FOR ONLY STATIONS 10261 AND							025
0	10263 AND THE SECOND FOR THE REMAINDER. AFTER 11 STATIONS WITH THE							026
0	SECOND UNIT THE CONDUCTIVITY CELL WAS REPLACED IN THE HOPE OF REDUCING							027
0	THE CALIBRATION DRIFT. FOLLOWING DOCUMENTATION APPLIES ONLY TO THE							028
0	SECOND CTD UNIT AND NOT TO STATIONS 10261 AND 10263.							029
0								030
0	**DATA CALIBRATION/QUALITY**							031
0								032
0	*PRESSURE SENSOR CALIBRATED IN LABORATORY SEPTEMBER 1980 USING DEAD							033
0	WEIGHT TESTER - DECK OFFSET WAS STABLE AT 8 DBAR. DIFFERENCE DURING							034
0	CRUISE BETWEEN PRESSURES FROM PAIRS OF REVERSING THERMOMETERS							035
0	(PROTECTED AND UNPROTECTED) AND SIMULTANEOUS CTD PRESSURE MEASURES,							036
0	EACH MADE AFTER 5 MINUTE STOP ON RAISING OF INSTRUMENT, WERE VERY							037
0	SMALL. 30 SUCH COMPARISONS IN RANGE 0-2000 DBAR GAVE MEAN DIFFERENC							038
0	OF 0.5 DBAR (CTD HIGHER) WITH STANDARD DEVIATION OF 2 DBAR. 52 IN							039
0	RANGE 2000-5600 DBAR GAVE MEAN DIFFERENCE OF 2 DBAR KID HIGHER)							040
0	WITH STANDARD DEVIATION OF A DBAR. A FURTHER CHECK WAS OBTAINED BY							041
0	CONVERTING PRESSURES AT THE BOTTOM OF THE CAST TO DEPTH, ADDING THE							042
0	PINGER WEIGHT ABOVE BOTTOM TO GIVE WATER DEPTH, AND COMPARING WITH THE							043
0	ECHO-SOUNDER DEPTH CORRECTED USING CARTER'S TABLES. FOR 25 SUCH							044
0	OBSERVATIONS IN THE DEPTH RANGE 5200-5500M, THE ECHO-SOUNDER DEPTH							045
0	EXCEEDED THE CTD CALCULATED DEPTH BY A MEAN OF 6M WITH A STANDARD							046
0	DEVIATION OF 5M,							047
0								048

RECORD

PLAIN LANGUAGE RECORD.

	1	2	3	4	5	6	7	8
	1234567890123456789012345678901234567890123456789012345678901234567890							
00	*TEMPERATURE SENSOR (PLATINUM RESISTANCE) CALIBRATED IN LABORATORY							049
0	SEPTEMBER 1980 BUT, IN COMPARSON WITH 90 REVERSING THERMOMETER							050
0	MEASUREMENTS TAKEN SIMULTANEOUSLY WITH CTD SENSOR MEASUREMENTS DURING							051
0	CRUISE, A CALIBRATION SHIFT WAS NOTED REQUIRING THE ADDITION OF AN							052
0	AMOUNT 0.044 + 0.00050012*RAWTEMP. DEG.C. - ORIGIN OF THIS ERROR, OF A							053
0	MAGNITUDE COMMONLY FOUND, REMAINS UNKNOWN. CORRECTED CTD TEMPERATURE							054
0	MINUS REVERSING THERMOMETER TEMPERATURE FROM 31 COMPARISONS DURING THE							055
0	CRUISE FOR TEMPERATURES GREATER THAN 5 DEG.C. GAVE A MEAN OF 0 DEG.C.							056
0	WITH A STANDARD DEVIATION OF 0.006 DEG.C. 59 COMPARISONS FOR							057
0	TEMPERATURES LESS THAN 5 DEC.C. GAVE A MEAN OF -0.001 DEC.C. WITH A							058
0	STANDARD DEVIATION OF 0.001 DEG.C.							059
0								060
0	DURING THE CRUISE BOTTLE SALINITIES AND REVERSING THERMOMETER MEASURE-							061
0	MENTS REVEALED A !!NEAR POTENTIAL TEMPERATURE (POTT) - PRACTICAL							062
0	SALINITY (S) RELATIONSHIP FOR POTT LESS THAN 2.6 DEG.C. OF 5 - 34.698							063
0	- 0098*POTT WITH A DATA SCATTER ABOUT THE LINE OF -0 0.002 IN							064
0	PRACTICAL SALINITY, APPROX SAME AS RMS ERROR OF SALINITY MEASUREMENTS.							065
0	FOR EACH STATION THE MEAN OF 20 CTD SALINITY ESTIMATES (2.1 < POTT <							066
0	2.2) WAS DETERMINED AND ADJUSTED TO FIT THE ABOVE RELATIONSHIP THUS							067
0	PRODUCING A MULTIPLICATIVE FACTOR FOR CORRECTING THE CTD SALINITIES.							068
0	FOR THE CELL USED ON STATIONS 13764-14 THE FACTOR VARIED BETWEEN							069
0	STATIONS (NOT SMOOTHLY) CORRESPONDING TO A PRACTICAL SALINITY CHANGE							070
c	OF 0.008. FOR THE CELL ON STATIONS 10275-94 THE CORRESPONDING							071
0	VARIATION WAS 0.004. IN THE 0-20CC DBAR RANGE 58 COMPARISONS DURING							072

RECORD 5 PLAIN LANGUAGE RECORD.

1 2 3 4 5 6

1234567890123456789012345678901234567890123456789012345678901234567890

00 THE CRUISE OF BOTTLE SALINITY WITH CORRECTED CTD SALINITY AT THE SAME 073
0 TEMPERATURE SAVE A PRACTICAL SALINITY MEAN OF 0.002 (CTD HIGHER) WITH 074
0 A STANDARD DEVIATION OF 0.008. IN THE 2C00-5600 DBAR RANGE 10 075
0 COMPARISONS AT THE SAME PRESSURE GAVE A MEAN OF 0.001 (CTD LOWER) WITH 076
0 A STANDARD DEVIATION OF 0.0025. 077
0 078
0 ---DATAPROCESSING- 079
0 *ORIGINAL VALUES WERE AVERAGED OVER AN INTERVAL OF ONE SECOND AND 080
0 CALIBRATION COEFFICIENTS AND CORRECTION FACTORS APPLIED. TO MATCH THE 081
0 SLOWER RESPONSE OF THE PLATINUM RESISTANCE THERMOMETER IN RELATION TO 082
0 THE OTHER SENSORS, THE TEMPERATURE WAS CORRECTED AS FOLLOWS - TEMPO - 083
0 TEMP + TOR*DELTAT WHERE TOR IS THE TEMPERATURE TIME CONSTANT (TAKEN AS 084
0 0.22 SEC), AND DELTAT IS THE DIFFERENCE BETWEEN THE INSTANTANEOUS 085
0 TEMPERATURE AT THE BEGINNING AND END OF THE AVERAGING INTERVAL. 086
0 *DATA EDITING DIFFERENCES BETWEEN SUCCESSIVE VALUES OF EACH PARAMETER 087
0 WERE EXAMINEE FIRST BY DETERMINING THE MEAN DIFFERENCE AND ITS 088
0 STANDARD DEVIATION AND THEN BY LISTING OUT ALL VALUES WHERE THE 089
0 DIFFERENCE WAS GREATER THAN SEVERAL STANDARD DEVIATIONS FROM THE MEAN 090
0 DIFFERENCE. THESE LISTS WERE THEN INSPECTED FOR GENUINELY SUSPECT 091
0 DATA WHICH WERE REPLACED BY LINEARLY INTERPOLATED VALUES. 092
0 *TO REMOTE THE EFFECT OF SHIPS HEAVE THE DATA CYCLES WERE SORTED BY 093
0 PRESSURE BEFORE ALL VALUES WERE FINALLY AVERAGED AT 5 DBAR INTERVALS, 094
0 CENTRES AT 2.5 DBAR, 7.5 DBAR --- 095
0 096

RECORD 6 PLAIN LANGUAGE RECORD.

1 2 3 4 5 6 7 8

1234567890123456789012345678901234567890123456789012345678901234567890

06 ---NOTEON CALIBRATION DATA- 097
0 098
0 THE UP CAST BOTTLE AND REVERSING THERMOMETER DATA FOR EACH STATION ARE 099
0 ENTERED IN THE SERIES HEADER RECORD TOGETHER WITH THE CORRECTED UPCAST 100
0 VALUES OF CTD PRESSURE AND TEMPERATURE. NOTE THAT THE CTD SALINITIES 101
0 IN THIS RECORD WERE TAKEN FROM THE DOWN CAST ~ FOR COMPARISON WITH THE 102
0 BOTTLE SALINITIES THE CTD SALINITY VALUES WERE EXTRACTED AT THE SAME 103
0 TEMPERATURE FOR OBSERVATIONS MADE SHALLOWER THAN 2000 DBAR. AND AT THE 104
0 SAME PRESSURE FOR OBSERVATIONS MADE DEEPER THAN 2000 DBAR. THIS 105
0 COMPENSATES FOR TEMPORAL VARIATIONS WITHIN THE THERMOCLINE BETWEEN THE 106
0 DOWN AND UP CASTS. 107
0 108
0 109
0 110
0 111
0 112
0 113
0 114
0 115
0 116
0 117
0 118
0 119
0 120

RECORD SERIES HEADER RECORD.

	1	2	3	4	5	6	7	
1234567890123456789012345678901234567890123456789012345678901234567890								
67	749010	UNITED KINGDOM			INST.OCEANOLOG.SCI. 851107122625	CTD DEMO 2		001
631 SHIP	474-74	DISC R.R.S. DISCOVERY			CRUISE117 19810119		19810212	002
6								003
6198102082356	198102090332		3753SON	17038OW	20 5518	999999999999		004
69999999 9999999 9999999 9999999 23A					A STN.10294999999		10	005
90	15230	36062	100	15226	36060	4960	11230	35548
9900	10787	36005	9880	10786	36000	14890	6877	35472
19930	4568	35137	19930	1567	35110	26920	3110	31970
32510	2740	34939	-9999	-9999	34934	39820	2574	31916
41940	2505	34903	-9999	-9999	34902	55700	2598	34898

RECORD DATA CYCLE RECORD.

	1	2	3	4	5	6	7	8
1234567890123456789012345678901234567890123456789012345678901234567890								
77	92	0	1					
	25	15260	36068	75	15262	36069	125	15262
	225	15265	36068	275	15261	36069	325	15265
	425	15265	36068	475	15266	36069	525	15267
	625	15268	36068	675	15269	36067	725	15271
	825	15264	36066	875	15260	36066	925	15256
	1025	15203	36060	1075	15076	36041	1125	11808
	1225	11164	35900	1275	14115	35906	1325	14060
	1425	13861	35876	1475	13782	35868	1525	13682
	1625	13496	35824	1675	13431	35811	1725	13364
	1825	13182	35781	1875	13032	35756	1925	12980
	2025	12841	35734	2075	12757	35719	2125	12722
	2225	12614	35705	2275	12603	35699	2325	12576
	2425	12496	35692	2475	12450	35685	2525	12405
	2625	12313	35672	2675	12254	35664	2725	12216
	2825	12142	35616	2875	12121	35643	2925	12099
	3025	12043	35634	3075	12020	35635	3125	11964
	3225	11864	35618	3275	11831	35612	3325	11818
	3425	11787	35607	3475	11766	35605	3525	11744
	3625	11704	35598	3675	11691	35597	3725	11669
	3825	11622	35589	3875	11609	35587	3925	11592
	4025	11558	35582	4075	11547	35580	4125	11537
	4225	11197	35573	A275	11483	35572	4325	11448
	4425	11372	35562	4175	11336	35557	4525	11307

RECORD 9 DATA CYCLE RECORD.

1 2 3 4 5 6 7 8
 1234567890123456789012345678901234567890123456789012345678901234567890

77	92	92	2											
4625	11266	3555C		4675	11239	35546		4725	11221	35549		4775	11198	35518
4825	11176	35544		1875	11159	35541		4925	11158	35544		4975	11148	355A8
5025	11142	35549		5075	11120	35549		5125	11112	35549		5175	11081	35550
5225	11062	35518		5275	11059	35549		5325	11051	35543		5375	11037	35550
5425	11021	35552		5175	11031	35557		5525	11031	35562		5575	11025	35562
5625	11037	35570		5675	11045	35575		5725	11039	35578		5775	11033	35579
5825	11026	35581		5875	11013	35583		5925	10998	35584		5975	10985	35588
6025	10972	35591		6075	10977	35599		6125	10979	35607		6175	10974	35613
6225	10972	35617		6275	10968	35623		6325	10966	35629		6375	10966	35640
6425	10966	35644		6475	10972	35651		6525	10972	35653		6575	10977	35664
6625	10982	35671		6675	11011	35684		6725	11023	35693		6775	11030	35697
6825	11008	35700		6875	13991	35704		6925	11011	35715		6975	11025	35722
1025	11018	35722		7075	11020	35724		7125	11058	35740		7175	11108	35762
7225	11140	35775		7275	11184	35791		7325	11241	35815		7375	11269	35835
7425	11210	35834		7475	11136	35823		7525	11101	35811		7575	11111	35827
7625	11098	35831		7675	11063	35823		7725	11067	35828		7775	11159	35861
7825	11183	35880		7875	11140	35873		7925	11189	35889		7975	11256	35909
8025	11332	35941		8075	11373	35961		8125	11419	35978		8175	11382	35988
8225	11247	35954		8275	11226	35646		8325	11329	35978		8375	11268	35977
8425	11139	35911		8175	11035	35925		8525	11071	35935		8575	11054	35914
8625	11116	35953		8675	11134	35968		8725	11078	35959		8775	10950	35936
8825	10903	35925		8875	10862	35918		8925	10872	35923		8975	10883	35934
9025	10888	35937		9075	10897	35941		9125	10934	35958		9175	10877	35953

RECORD 10 DATA CYCLE RECORD.

1 2 3 4 5 6 7 8
 1234567890123456789012345678901234567890123456789012345678901234567890

77	92	184	3											
9225	10903	35950		9275	10901	35968		9325	10876	35962		9375	10872	35961
9425	10864	35965		9475	10813	35969		9525	10817	35975		9575	10821	35975
9625	10765	35964		9675	10712	35958		9725	10761	35964		9775	10745	35966
9825	10709	35964		9875	10650	35951		9925	10680	35963		9975	10692	35972
10025	10689	35976		10075	10766	35998		10125	10819	36031		10175	10820	35027
10225	10698	36007		10275	10706	36008		10325	10643	35998		10375	10586	35987
10125	10555	35983		10475	10575	35989		10525	10575	35994		10575	10537	35991
10625	10493	35985		10675	10488	35984		10725	10478	35988		10775	10453	35984
10825	10420	35982		10875	10386	35976		10925	10372	35976		10975	10383	35989
11025	10385	35994		11075	10374	35997		11125	10355	35998		11175	10335	35998
11225	10303	35999		11275	10260	35997		11325	10228	35991		11375	10236	35998
11425	10149	35988		11475	10091	35975		11525	10032	35968		11575	10010	35964
11625	10007	35963		11675	9994	35967		11725	9976	35968		11775	9939	35963
11825	9860	35955		11875	9777	35941		11925	9729	35933		11975	9698	35929
12025	9658	35923		12075	9641	35921		12125	9615	35918		12175	9586	35913
12225	9575	35911		12275	9555	35910		12325	9542	35908		12375	9562	35918
12425	9521	35913		12475	9133	35897		12525	9404	35892		12575	9400	35896
12625	9354	35893		12675	9267	35813		12725	9198	35863		12775	9105	35845
12825	9026	35831		12875	8965	35820		12925	8874	35801		12975	8814	35793
13025	8746	35780		13075	8694	35770		13125	8706	35771		13175	8659	35775
13225	8633	35770		13275	8580	35764		13325	8544	35757		13375	8474	35747
13425	8393	35732		13475	8286	35715		13525	8224	35702		13575	8195	35695
13625	8160	35689		13675	8129	35683		13725	8062	35674		13715	8046	35669

ETC. ETC.

END OF FILE.

1 2 3 4 5 6 7 8
 1234567890123456789012345678901234567890123456789012345678901234567890

67	749010	UNITED KINGDOM	INST. OCEANOGR. SCI.	0205061030	CTD DEMO 2	001
68	SHIP	474-7401SC R.R.S. DISCOVERY	CRUISE117	19810115	19910212	002
69	6158102822356	198102090332	375050N	170380W	20 5519	999999999999
70	90	15230	36062	100	15226	36060
71	9900	10787	36005	5880	10786	36000
72	19930	4568	36137	19930	4557	35140
73	32543	2748	34939	-9999	-9999	34934
74	44340	2505	34303	-9999	-9999	34902
					4960	11230
					35548	-9999
					6877	38472
					26920	3110
					39934	2574
					55700	2598
						34398
						55560
						2607
						34858

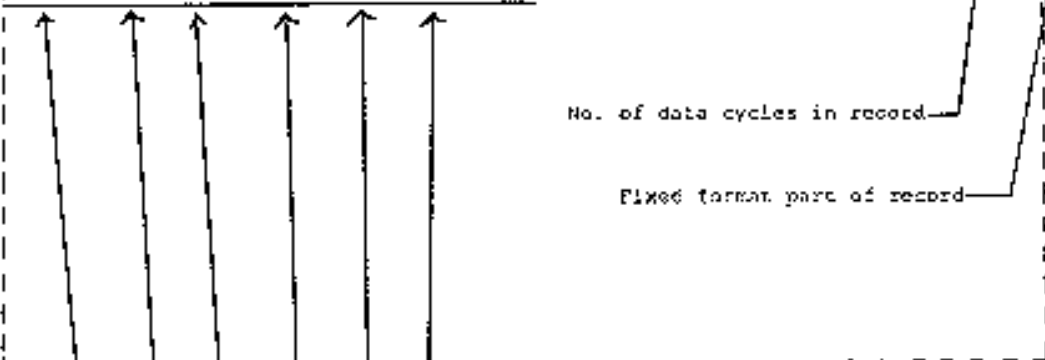

No. of data cycles in record

Fixed format part of record

Minta data cycle in record

Practical salinity (bench salinometer) = 34.933

Sea temperature (reversing thermometer) = no measurement

Sea Pressure (reversing thermometers) = no measurement

Practical salinity (CTD probe) = 34.903

Sea temperature (CTD probe) = 2.503°C

Sea pressure (CTD probe) = 4499.0 dbars

CPS STANDARD SUBSET

CTD DATA

ANNOTATED LISTING OF SAMPLE DATA CYCLE RECORD

Third data cycle in record

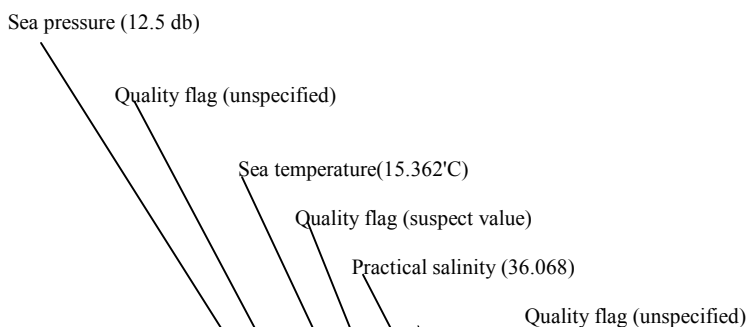
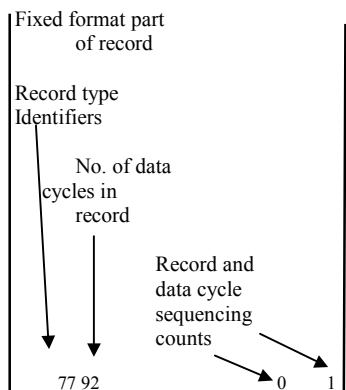

25	15260	36068	75	15262	36069	125	15362	36068	175	15264	36069
225	15265	36068	275	15264	36069	325	15265	36069	375	15267	36068
125	15265	36068	475	15266	36069	525	15267	36068	575	15270	36069
625	15268	36068	675	15269	36067	725	15271	36068	775	15271	36068
825	15261	36066	875	15260	36066	925	15256	36065	975	15256	36065
1025	15203	36060	1075	15076	36011	1125	11808	35998	1175	14326	35936
1225	14161	35900	1275	14115	35906	1325	11060	35900	1375	13984	35892
1425	13861	35876	1475	13782	35868	1525	13682	35851	1575	13571	35811
1625	13196	35821	1675	13131	35811	1725	13361	35806	1775	13279	35794
1825	13182	35781	1875	13032	35756	1925	12980	35751	1975	12905	35738
2025	12811	35734	2075	12757	35719	2125	12722	35713	2175	12693	35711
2225	12644	35705	2275	12603	35699	2325	12576	35700	2375	1254	35696
2425	12496	35692	2475	12150	35685	2525	12105	35682	2575	1234	35674
2625	12313	35672	2675	12254	35661	2725	12216	35656	2775	12167	35650
2825	12142	35646	2875	12121	35643	2925	12099	35611	2975	12059	35638
3025	12043	35634	3075	12020	35635	3125	11964	35627	3175	11946	35626
3225	11864	35618	3275	11831	35612	3325	11818	35610	3375	11808	35609
3425	11787	35607	3475	11766	35605	3525	11144	35602	3575	11727	35600
3625	11701	35598	3675	11691	35597	3725	11669	35595	3775	11610	35591
3825	11622	35589	3875	11609	35587	3925	11592	35585	3975	11571	35584
1025	11558	35582	4075	11517	35580	1125	11537	35578	1175	11519	35576
4225	11497	35573	4275	11483	35572	4325	11418	35569	1375	11A04	35563
4125	11372	35562	4175	11336	35557	4525	11307	35553	4575	11286	35551

GF3 STANDARD SUBSET

CTD DATA

SECTION 2.1 APPENDIX D: ALGORITHMS FOR PRACTICAL SALINITY COMPUTATION

The following FORTRAN Function designed by Fofonoff and Millard (UNESCO, 1983) implements the 1978 definition of Practical Salinity as a function of conductivity ratio and also the inverse calculation.

```

C*****
C
C      REAL FUNCTION SAL78(CND,T,P,M)
C
C*****
C      THE CONDUCTIVITY RATIO (CND) = 1.0000000 FOR SALINITY = 35 PSS-78
C      TEMPERATURE = 15.0 DEG. CELSIUS , AND ATMOSPHERIC PRESSURE.
C
C      FUNCTION TO CONVERT CONDUCTIVITY RATIO TO SALINITY (M = 0)
C      SALINITY TO CONDUCTIVITY RATIO (M = 1, CND BECOMES INPUT SALINITY)
C
C      REFERENCES:      ALSO LOCATED IN UNESCO REPORT # 37 1981
C      PRACTICAL SALINITY SCALE 1978: E.L. LEWIS IEEE OCEAN ENG. JAN. 1980
C***
C      UNITS:
C
C      PRESSURE P      DECIBARS
C      TEMPERATURE T  DEG CELSIUS (1PTS=68)
C
C      CONDUCTIVITY CND  RATIO      (M=0)
C      SALINITY SAL78    (PSS-78)   (M=1)
C***
C      CHECKVALUES:
C      SAL78=1.888091 :CND= 40.0000,T=40 DEG C,P= 10000 DECIBARS:      M= 1
C      SAL78=40.00000 :CND=1.888091,T=40 DEG C,P=10000 DECIBARS:      M=0
C***
C      SAL78 RATIO: RETURNS ZERO FOR CONDUCTIVITY RATIO: < 0.0005
C      SAL78: RETURNS ZERO FOR SALINITY: < 0.02
C***
C      INTERNAL FUNCTIONS
C***
C      PRACTICAL SALINITY SCALE 1978 DEFINITION WITH TEMPERATURE CORRECTION
C
C      XT=T-15.0 : XR=SQRT(XT)
C
C      SAL(XR,XT) = (((((2.7081*XR-7.0261)*XP+14.0341)*XR+25.3851)*XR
C      X-0.1692)* XR+0.0080
C      X *(XP/(1.0+0.0162*XT)) + ((((-0.0144*XP+
C      X 0.0636)*XR-0.0375)*XR-0.0066)*XR-0.0056)*XR+0.0005)
C
C      DSAL(XR,XT) FUNCTION FOR DERIVATIVE OF SAL(XR,XT) WITH XR.
C      DSAL(XR,XT) = (((((13.5405*XR-28.1044)*XR+42.2823)*XR+50.7702)*XR
C      X -0.1692)+(XT/(1.0+0.0162*XT)) * ((((-0.0720*XR+0.2544)*XR
C      X -0.1125)*XR-0.0132)*XR-0.0056)
C      FUNCTION RT35 C(35,T,0)/C(35,15,0) VARIATION WITH TEMPERATURE
C      WITH TEMPERATURE.
C
C      RT35(XT) = (((1.0031E-9*XT-6.9693E-7)*XT+1.104259E-4)*XT
C      X + 2.00564E-2)*XT + 0.6766097
C      POLYNOMIALS OF RP: C(S,T,P)/C(S,T,0) VARIATION WITH PRESSURE
C      C(XP) POLYNOMIAL CORRESPONDS TO A1-A3 CONSTANTS: LEWIS 1980
C      C(XP) = ((3.989E-15*XP-6.370E-10)*XP+2.070E-5)*XP
C      B(XT) = (4.464E-4*XT+3.426E-7)*XT + 1.0

```

```

C      A(T) POLYNOMIAL CORRESPONDS TO B3 AND B4 CONSTANTS: LEWIS (1980)
      A(T) = -3.107E-3*T + 0.4215
C***
C      ZERO SALINITY/CONDUCTIVITY: TRAP

      SAL78=0.0
      IF((M.EQ.0).AND.(CND.LE.5E-4)) RETURN
      IF((M.EQ.1).AND.(CND.LE.0.00)) RETURN
C***

      DT = T - 15.0

C SELECT BRANCH FOR SALINITY (K=0) OR CONDUCTIVITY (M=1)
      IF(M.EQ.1) GO TO 10
C ***

C CONVERT CONDUCTIVITY TO SALINITY

      R = CND
      RT = R/(RT35(T)*(1.0 + C(P)/(B(T) + A(T)*R)))
      NT = SQRT(ABS(RT))
      SAL78 = SAL(RT,DT)
      RETURN

C*** END OF CONDUCTIVITY TO SALINITY SECTION
C***

C INVERT SALINITY TO CONDUCTIVITY BY THE
C NEWTON-RAPHSON ITERATIVE METHOD.

C***

C FIRST APPROXIMATION

      10 RT = SQRT(CND/35.0)
      SI = SAL(RT,DT)
      N = 0

C
C ITERATION LOOP BEGINS HERE WITH A MAXIMUM OF 10 CYCLES
C
      15 RT = RT + (CND - SI)/DSAL(RT,DT)
      SI = SAL(RT,DT)
      N = N + 1
      DELS = ABS(SI - CND)
      IF((DELS.GT.1.0E-4).AND.(N.LT.10))GO TO 15
C
C END OF ITERATION LOOP
C
C COMPUTE CONDUCTIVITY RATIO
      RT RT35(T)*RT*RT
      AT A(T)
      BT B(T)
      CP C(P)
      CP RTT*(CP + BT)
      BT BT - RTT*AT
C
C SOLVE QUADRATIC EQUATION FOR R:  $R^2 RT35^2 RT^2 (1 + C/AR + B)$ 
C
      R = SQRT(ABS(BT*BT + 4.0*AT*CP)) - BT

C CONDUCTIVITY RETURN

      SAL78 = 0.5*R/AT
      RETURN
      END

```

SECTION 2.1 APPENDIX E: ICE-POINT CHECKS OF THERMOMETERS

The equipment needed for checking ice-points consists only of the normal thermometer reading equipment plus a wide mouth Dewar flask about 8cm internal diameter and long enough to hold the thermometer, a large Dewar of 15 cm internal diameter, a source of clean and pure shaved ice, a pail to hold it, which is used for nothing else, some pure water either distilled or, at least, de-ionised, an aluminium or stainless steel stirrer. A pair of light rubber gloves would be helpful.

The procedure is as follows:

All of the utensils, the stirrer, and the thermometer are carefully cleaned with mild detergent solution then rinsed two or three times with ordinary water, at room temperature. The larger Dewar is 2/3 filled with distilled water, and shaved ice is added (avoiding contamination by hands) with strong stirring until it can be made into a water-ice slush mixture thin enough that the stirrer will pass through it easily but thick enough that some ice can be picked up on the stirrer if it is lifted out slowly. The slush-ice is then transferred with the stirrer to fill the smaller Dewar. Aerated distilled water, precooled by ice, is added to fill it almost to the top, but preferably not enough to float the ice. The precooled thermometer is then thrust as far as possible into the centre of the ice mixture, i.e. with liquid-in-glass thermometers until the ice-point marking is just above the lip of the Dewar. With thermocouples and resistance thermometers it is preferable to have at least 30cm of immersion. If there is any doubt as to the efficiency of immersion the thermometer should be read a second time with 5cm less immersion to confirm that the reading is independent of immersion depth. It is absolutely essential that the sensing element does not go beyond the bottom of the ice since very pronounced temperature layering can exist in the water below ice level.

Final readings should not be taken until temperature equilibrium has been achieved as indicated by a constant reading over several minutes. A useful check against contamination is to quickly withdraw the thermometer and re-insert it in a different location and repeat the measurement procedure.

With liquid-in-glass thermometers an infrared filter is used on the illuminator to prevent heating of the bulbs by radiation. In very precise work or when immersion is limited a clean aluminium foil over the top of the ice should be used to prevent transmitted radiation from affecting the temperature of the sensing element. For very best accuracy resistance thermometer readings should be taken at two currents, and extrapolated to zero input power, but this is not usually necessary when checking icepoints if identical conditions are maintained.

It is extremely important that all equipment be clean and rinsed. The ice should not be touched by the hands at any time, but washed rubber gloves can be used provided they do not touch the outside of any containers. The ice is best made in an ice machine that does not freeze all of the water since the freezing process helps in the purification and concentrates the impurities in the unfrozen part. With commercial ice that is frozen in large blocks the centre of the block, which freezes last, should not be used, just the clear outer layers with the surface washed to avoid contamination.

BIBLIOGRAPHY

Reports prepared as input to the Working Group

Ginzkey, L. and W. Zenk, 1980. Conductivity observations in Oceanography. Inst. fur Meereskunde, Kiel (Unpub. Man.) 25pp.

Gross, P.L., 1981. CTD Data Processing. EDIS/NOAA, Washington DC, USA, (Unpub. Man.) 28pp.

Millard, R., 1981. CTD Calibration and Data Processing Techniques Using the 1978 Practical Salinity Scale, Woods Hole, MA, USA (Unpub. Man.) 19pp

Perkin, R.C. and E.L. Lewis, 1982. Design of CTD Observational Programmes in Relation to Sensor Time Constants and Sampling Frequencies. Institute of Ocean Sciences, Patricia Bay, Sidney, B.C., Canada. Can. Tech. Rept. of Hydrog. and Ocean Sci. No.7 47 pp.

Peters, H., 1976. GATE,CT13 data measured on the FRO ships. Shipboard operation-calibration-editing. Ber. Inst.f.Meeresk. Kiel, v22,16pp.

Striggow, K., 1981. CTD intercomparisons. IfM Rostock-Warnemunde (Unpub. Man.) 12pp.

REFERENCES

Brown, N.L., 1974. A precision CTD microprofiler, IEEE Conf. on Engineering in the Ocean Env't., vol 2, pp 270-278

Dauphinee, T.M., 1972. Equipment for rapid temperature-conductivity-depth surveys. Oceanology International 1972 Conf. Proc., pp53-57

Fofonoff, N.P., S.P. Hayes, and R.C. Millard, 1974. WHOI/Brown CTD microprofiler: Methods of Calibrating and Data Handling. WHOI-74-78, Woods Hole MA,USA 66pp.

Cold, B. and C.M. Rader, 1969. Digital Processing of Signals. McGraw Hill, New York 269pp

Gregg, M.C., T.B. Meagher, E. Aagard and W. Hess, 1981. A Salt-stratified Tank for measuring the Dynamic Response of Conductivity Probes.

Holloway, J.L., 1958. Smoothing and filtering of Time Series and Space Fields in Advances in Geophysics vol 4 Academic Press New York pp 351-389

Horne, E.P.W., and J.M.Toole, 1980. Sensor Response Mismatches and Lag Correction Techniques for Temperature Salinity Profilers. J.Phys.Oc.,vol 10 pp 1122-1130

Hurst, W.S., 1975. Note on the Measurement of the Response of Oceanographic Temperature Sensors. J.Geophys. Res.,vol 80 pp2663-2666

Irish, J.D., and M.Levine, 1978. Digitizing error from Period and Frequency Counting Techniques. D.S.R., vol25,pp. 211 ~219

Kroebel, W., 1980. A thermometer with a time constant of about 15-2ms, IEEE Conf. Record Oceans '80, pp 44-48

Millard, R., J. Toole, and M.Swartz, 1980. A fast responding temperature Measurement System for CTD Applications. Ocean Engineering vol 7 pp 413-426

Scarlet, R.I., 1975. A data processing method for salinity, temperature, depth profiles. Deep Sea Res., vol 22 pp509-515

Striggow, K., and R. Dankert, 1985. The exact theory of inductive conductivity sensors for oceanographic application. IEEE J. of Ocean Eng., OE-10(2), pp. 175-179

Topham D.R., 1981. Notes on the Transfer Function of a Conductivity Cell. Institute of Ocean Sciences, Patricia Bay, Sidney, B.C., Canada. Unpubl. manuscript.

UNESCO, 1981. The Practical Salinity Scale 1978 and the International Equation of State of Seawater 1980. 10th report of the Joint Panel on Oceanographic Tables and Standards. Technical Papers in Mar. Sci. No. 36

UNESCO, 1987. Technical Description of the GF3 Format and Code Tables. Manuals and Guides No. 17, vol. 2

Walker, E.R., 1978. Laboratory Determination of the Responses of Thermometer and Conductivity Cell of the Guildline 81801A. Institute of Ocean Sciences, Patricia Bay, Sidney, B.C. Canada. IOS Note 7. 33pp unpub. manuscript

SECTION 2.2

**UKOOA RECOMMENDED PROCEDURES FOR
VALIDATION AND DOCUMENTATION OF
OIL COMPANY METOCEAN DATA**

UKOOA



UK Offshore Operators Association Limited

**UKOOA RECOMMENDED PROCEDURES FOR
VALIDATION AND DOCUMENTATION OF
OIL COMPANY METOCEAN DATA**

Department of Energy

Project 76

April 1987

ABBREVIATIONS AND DEFINITIONS

ABBREVIATIONS

NODB	- National Oceanographic Data Bank
QAD	- Quality Assurance Document
UKOOA	- United Kingdom Offshore Operators Association

DEFINITIONS

Data Validation - this is the sum of all checks and tests applied to the instruments and the data to assess their validity, and comprises four main aspects: instrumentation checks and calibrations; documentation of deployment parameters; automatic quality control of data; and oceanographic assessment.

Quality Assurance Document - check list of data validation procedures applied to a data set.

Instrument Checks - these comprise tests on the sensor output and processing equipment to ensure that they are functioning correctly and that they are performing within the manufacturer's specification.

Instrument Calibrations - these comprise tests which provide sufficient information to allow the production of calibration curves or equations for the instrument or sensor, and these curves or equations are applied to the data obtained during the measurement period.

Raw Data - data sampled at high frequency (of the order of 1-2 Hz), which are averaged or analysed to provide values of processed data.

Processed Data - data averaged or analysed from raw data, or obtained as averaged or analysed values directly from the instrument.

Automatic Quality Control Checks - these are checks on the data applied by computer, which test for timing errors, physical limits of the data, constant values, rates of change, and the identification of gaps.

Oceanographic Assessment - this is an assessment of the oceanographic 'reasonableness' of the data, comprising checks on expected patterns or trends and comparisons with other data sources.

Automatic Flags - these are flags associated with the automatic quality control checks.

Data Qualifiers - these indicate the validity of the data according to the assessment of the analyst.

The Validated Data Set - this constitutes the final processed data set which has undergone quality control, oceanographic assessment, and editing, and in which each data point has been qualified and flagged.

Sampling Rate - the frequency at which raw data are sampled by a sensor.

Sampling Period - the period of time over which an individual processed data sample is obtained.

Sampling Interval - the time interval between the start of successive sampling periods.

CONTENTS

	Page
1. INTRODUCTION	103
1.1 Summary	103
1.2 Validation of Metoccan Data	103
1.3 Quality Assurance Documents	103
1.4 Minimum Requirements for Data Validation	103
2. QUALITY ASSURANCE DOCUMENTS	104
2.1 Introduction	104
2.2 QADs	104
2.3 Responsibility for QAD Completion	104
3. INSTRUMENT CHECKS & CALIBRATIONS	110
3.1 Introduction	110
3.2 Data Collection Programmes of Short Duration	110
3.3 Data Collection Programmes of Long Duration	111
3.4 Additional Considerations	111
3.5 Documentation	112
4. DOCUMENTATION OF DEPLOYMENT PARAMETERS	114
5. QUALITY CONTROL PROCEDURES	114
5.1 Introduction	114
5.2 Automatic Quality Control of Data	114
5.3 Oceanographic Assessment	115
5.4 Flagging & Editing of Data	115
5.5 Validated Data Set	117
6. REPORTING & DATA PRESENTATIONS	117
6.1 Introduction	117
6.2 Reporting	117
6.3 Banking of Data	118

		Page
APPENDIX A	WAVE DATA	121
A1	General Discussion	121
A2	Quality Control of Non-Directional Wave Data	124
A3	Quality Control of Directional Wave Data	131
A4	Documentation	137
APPENDIX B	CURRENT METER DATA	147
B1	General Discussion	147
B2	Quality Control of Current Meter Data	148
B3.	Documentation	158
APPENDIX C	WATER LEVEL DATA	167
C1	General Discussion	167
C2	Quality Control of Water Level Data	168
C3	Documentation	173
APPENDIX D	METEOROLOGICAL DATA	185
D1	General Discussion	185
D2	Quality Control of Meteorological Data	186
D3	Documentation	192
 LIST OF FIGURES		
A1	Flow Diagram of Quality Control Procedures for Non-Directional Wave Data	130
A2	Flow Diagram of Quality Control Procedures for Directional Wave Data	136
B1	Flow Diagram of Quality Control Procedures for Current Meter Data	157
C1	Flow Diagram of Quality Control Procedures for Water Level Data	172
D1	Flow Diagram of Quality Control Procedures for Meteorological Data	191

1. INTRODUCTION

1.1 SUMMARY

This document presents a set of procedures for validating the data for meteorological and oceanographic (metocean) variables -- waves, currents, water levels, and winds -- prior to data-banking. Additional variables often measured in conjunction with currents (i.e. sea temperature, conductivity/salinity and pressure/head of water), and winds (i.e. barometric pressure, relative humidity, air temperature, and sea surface temperature) are also considered. The procedures have been formulated for metocean data collected in UK waters, so that values used have been related to the environmental conditions generally prevailing in this region. However, the basic principles underlying the procedures are considered to be more widely applicable.

1.2 VALIDATION OF METOCEAN DATA

The four major aspects of metocean data validation are:

- a) Instrumentation checks and calibrations which include calibration /checks of sensor response; tests on instrument or system electronics; and checks on data processing and recording equipment.
- b) The documentation of deployment parameters which includes definition of the location and duration of the measurements; method of deployment of the instrumentation; and sampling scheme used for the measurements.
- c) Automatic quality control of data which comprises a series of tests on the data to identify erroneous and anomalous values in order to establish whether the data have been corrupted in any way.
- d) Oceanographic assessment which includes an assessment of the results of conditions a) to c); and an assessment of the oceanographic 'reasonableness' of the data, comprising checks on expected patterns or trends and comparisons with other data sources. Two levels of oceanographic assessment are recognised: a lower level in which the assessment is mostly applied manually to the data set; and a higher level comprising more detailed investigation, and further analysis of the data.

Each of these aspects is considered in more detail in the following sections (Sections 3 to 5), while specific quality control procedures are outlined in Appendices A to D. In addition, comments are made in Section 6 on the reporting of data gathering programmes, as this is the means whereby the results of the data validation process are presented. Included in Section 6 are general requirements for the submission of data for banking with the National Oceanographic Data Bank (NODB).

1.3 QUALITY ASSURANCE DOCUMENTS

A set of standard quality assurance documents (QADs) for metocean data is presented in Section 2. A QAD is a check list indicating whether particular validation procedures have been applied or not to a data set. It is initially completed by the data gatherer, and becomes a definitive summary of the data set. It should accompany each individual data set wherever that data set is transferred. Any data validation procedures applied to the data at a later date can thus be incorporated into the QAD. No connotation of judgement on absolute data validity is implied by the QAD. However, they should allow the potential user of a data set, who is not conversant with the data, to assess the level to which validation has been applied, and thus the applicability of the data set to his particular data requirements.

1.4 MINIMUM REQUIREMENTS FOR DATA VALIDATION

The data validation procedures specified in this document, at least up to the lower level of oceanographic or meteorological assessment, are considered to form the required standard for a

validated data set. However, it is realised that in practice this requirement may not be fully realised. This does not mean that the aim of the specifications should be lowered; rather that the data should be related to this standard and any differences noted.

It should also be recognised that there are certain data validation procedures which must be applied to a data set, otherwise the integrity of the data is seriously compromised.

These procedures are

- a) one full check or calibration of the instrument
- b) complete documentation of the deployment parameters
- c) timing checks on the raw and processed data
- d) absolute value checks on the raw and processed data
- e) a lower level oceanographic or meteorological assessment

2. QUALITY ASSURANCE DOCUMENTS

2.1 INTRODUCTION

Quality Assurance Documents (QADs) summarise the data validation procedures applied to metocean data sets. They are essentially check lists indicating the procedures which have been undertaken in validating metocean data, and the source documents to which reference can be made for details of these procedures. In addition, any significant comments relating to the procedures can be stated. They therefore allow a rapid assessment to be made of the level to which data validation procedures have been applied to a particular data set.

A QAD, filled in as necessary, should be appended to each individual metocean data set (or each discrete data sub-set for data collection programmes of long duration) upon completion of the data validation by the data gatherer. This QAD should then accompany this data set.(or sub-set) wherever it is transferred, since it provides a definitive summary of the data validation applied to the data. Any subsequent validation procedures which are applied can then be incorporated into the QAD, and referenced.

2.2 QADs

QADs for the main categories of metocean data are presented in Figures 2.1 to 2.5. Two are provided for waves; one for non-directional (digital or analogue) data and one for directional data. Supplementary data, often measured in conjunction with currents and winds, are included on the respective forms, but need to be specified. While this requirement has resulted in some loss of detail for these supplementary data, it has allowed the forms to be standardised, and the number of forms to be kept to a minimum.

2.3 RESPONSIBILITY FOR QAD COMPLETION

Initial responsibility for completing the QAD lies with the data gatherer, although it is the responsibility of the client to ensure that it has been filled in correctly. Responsibility for incorporating any subsequent validation undertaken (e.g. by the client) lies with the analyst performing those validation procedures, and these procedures must be adequately referenced.

Finally, responsibility for completing section F of the QAD headed 'Data Tape and Documentation for Banking' lies with the NODB (or any other archiving authority) which is archiving the data, since these aspects refer to the data tape submitted for banking.

QUALITY ASSURANCE DOCUMENT FOR DIGITAL OR ANALOGUE NON-DIRECTIONAL WAVE DATA SET

LOCATION PERIOD OF MEASUREMENTS INSTRUMENT

DATA VALIDATION PROCEDURE		*	Y/N	Source Document & Comments
A. INSTRUMENT CHECKS AND CALIBRATIONS				
1. Sensor output check	- before deployment			
	- routine			
	- after recovery			
2. Processing equipment check	- before deployment			
	- routine			
	- after recovery			
3. Sensor calibration curve	- manufacturer's			
	- derived			
	- applied			
B. DOCUMENTATION OF DEPLOYMENT PARAMETERS				
1. information provided on	- location and duration of measurements			
	- instrument configuration			
	- instrument sampling scheme			
	- maintenance visits/actions			
	- external/internal influence on data			
C. AUTOMATIC QUALITY CONTROL OF DATA				
1. Raw data Q.C. tests	- timing check	2.1.1		
	- absolute value check	2.1.2a		
	- data limit check	2.1.3d		
	- rate of change check	2.1.2b		
	- consecutive equal value check	2.1.3a		
	- wandering mean check	2.1.3b		
	- data stability check	2.1.3c		
	- visual inspection of raw data	2.1.4		
2. Processed data Q.C. tests	- test signal analogue data only)	2.2.2		
	- timing check	2.3.1		
	- H_s, H_{max}, T_p, T_p in bounds	2.3.3		
	- wave steepness	2.3.4		
	~ stationarity	2.3.5		
	- high frequency energy check	2.3.2a		
	~ low frequency energy check	2.3.2b		
D. OCEANOGRAPHIC ASSESSMENT				
1. Assessment checks	- inspection of time series	2.4.2a		
	- inspection H_s/T_z scatter plot	2.4.2b		
	- expected wind/wave correlations	2.4.2c		
	~ wave climate comparisons	2.4.2d		
	- inspection of spectra	2.4.2e		
E. REPORTING AND DATA PRESENTATION				
Report	- interim			
	- final			
2. Data presentation	~ interim			
	- final			
3. Data submitted for banking				
F. MAGNETIC TAPE AND DOCUMENTATION FOR BANKING				
1. Data tape	- header information as specified			
	- data in format as specified			
	- all suspect data flagged as specified			
	- edited data qualified as specified			
2. Documentation	- standard documentation provided	4		
	- data listings provided			

NOTE: Tick Box Y/N only if specified action or check has been undertaken; otherwise leave blank

*These notes refer to relevant sections in Appendix A of UKOOA Recommended Procedures for Validation and Documentation of Oil Company Metocean Data

QUALITY ASSURANCE DOCUMENT FOR DIRECTIONAL WAVE DATA SET

LOCATION

PERIOD OF MEASUREMENTS

INSTRUMENT

DATA VALIDATION PROCEDURE		*	Y/N	Source Document & Comments
A. INSTRUMENT CHECKS AND CALIBRATIONS				
1. Sensor output check	- before deployment			
	- routine			
	- after recovery			
2. Processing equipment check	- before deployment			
	- routine			
	- after recovery			
3. Sensor calibration curve	- manufacturer's			
	- derived			
	- applied			
B. DOCUMENTATION OF DEPLOYMENT PARAMETERS				
1. Information provided on	- location and duration of measurements			
	- instrument configuration			
	- instrument sampling scheme			
	- maintenance visits/actions			
	- external/internal influence on data			
C. AUTOMATIC QUALITY CONTROL OF DATA				
1. Raw data Q.C. tests	- timing check	3.1.2		
	- absolute value checks	3.1.3		
	- data limit checks	3.1.4		
	- rate of change checks	3.1.5		
	- stationarity checks	3.1.6		
	- visual inspection of raw data			
	- other (specific			
2. Processed data Q.C. tests	- timing checks	3.2.1		
	- H_s , H_{MAX} , T_z , T_p in bounds	2.3.3		
	- wave steepness (from H_s and T_z)	2.3.4		
	- stationarity	2.3.5		
	- heave spectra checks	3.2.2		
	- check ratio (R) tests	3.2.3a		
	- zero expectation cross-spectra checks	3.2.3b		
	- mean wave direction (θ_2) check	3.2.4a		
	- rms spread of mean wave direction (θ_2)	3.2.4b		
	- buoy heading	3.2.6		
D. OCEANOGRAPHIC ASSESSMENT				
1. Assessment checks	- inspection of time series	2.4.2a		
	- inspection H_s/T_z scatter plot	2.4.2b		
	- expected wind/wave correlations	3.3.2a		
	- inspection of time series of R	3.3.2c		
	- frequency distribution of θ_2 check	3.3.2b		
	- inspection of heave spectra	2.4.2e		
	- wave climate comparisons	2.4.2d		
E. REPORTING AND DATA PRESENTATION				
1. Report	- interim			
	- final			
2. Data presentation	- interim			
	- final			
3. Data submitted for banking				
F. MAGNETIC TAPE AND DOCUMENTATION FOR BANKING				
1. Data tape	- header information as specified			
	- data in format as specified			
	- all suspect data flagged as specified			
	- edited data qualified as specified			
2. Documentation	- standard documentation provided	4		
	- data listings provided			

NOTE: Tick Box Y/N only if specified action or check has been undertaken; otherwise leave blank

*These notes refer to relevant sections in Appendix A of 'UKOOA Recommended Procedures for Validation and Documentation of Oil Company Metocean Data

QUALITY ASSURANCE DOCUMENT FOR CURRENT DATA SET

LOCATION PERIOD OF MEASUREMENTS INSTRUMENT

DATA VALIDATION PROCEDURE		*	Y/N	Source Document & Comments
A. INSTRUMENT CHECKS AND CALIBRATIONS				
1. Sensor output check - currents (specify others in comments)	- before deployment			
	- routine			
	- after recovery			
2. Processing equipment check - currents (specify others in comments)	- before deployment			
	~ routine			
	- after recovery			
3. Sensor calibration curve - currents (specify others in comments)	- manufacturer's			
	- derived			
	- applied			
B. DOCUMENTATION OF DEPLOYMENT PARAMETERS				
1. Information provided on	- location and duration of measurements			
	- instrument configuration			
	- instrument sampling scheme			
	- maintenance visits/actions			
	- external/internal influence on data			
C. AUTOMATIC QUALITY CONTROL OF DATA				
1. Raw data Q.C. tests	- if applicable specify			
2a. Processed data Q.C. tests - current data	~ timing check	2.1.2		
	- absolute value check	2.1.4a		
	~ date limit check	2.1.4b		
	- rate of change check	2.1.5		
	~ stationarity	2.1.6		
	- successive current max-min range check	2.1.8		
	- successive current max time check	2.1.9		
2b. Processed data Q.C. tests - other sensor data (specify)	- timing check	2.1.2		
	- absolute value check	2.1.4a		
	- data limit check	2.1.4b		
	- rate of change check	2.1.5		
	- stationarity	2.1.6		
D. OCEANOGRAPHIC ASSESSMENT				
1. Assessment checks - current data	- tidal signal	2.2.2a		
	- tidal current comparisons	2.2.2a		
	- current profile	2.2.2a		
	- residual current 'events'	2.2.2a		
	- harmonic constituents	2.2.2b		
	- inspection of residual Lime series	2.2.2b		
2. Assessment checks - other sensor data (specify)	- range and mean	2.2.3-5		
	- trends	2.2.3-5		
	- profile	2.2.3-5		
	- 'events'	2.2.3-5		
E. REPORTING AND DATA PRESENTATION				
1. Report	- interim			
	- final			
2. Data presentation	- interim			
	- final			
3. Data submitted for banking				
F. MAGNETIC TAPE AND DOCUMENTATION FOR BANKING				
1. Data tape	- header information as specified			
	~ data in format as specified			
	- all suspect data flagged as specified			
	~ edited data qualified as specified			
2. Documentation	- standard documentation provided	3		
	- data listings provided			

NOTE: Tick Box Y/N only if specified action or check has been undertaken; otherwise leave blank

*These notes refer to relevant sections in Appendix A of 'UKOOA Recommended Procedures for Validation and Documentation of Oil Company Metocean Data

QUALITY ASSURANCE DOCUMENT FOR WATER LEVEL DATA SET

LOCATION PERIOD OF MEASUREMENTS INSTRUMENT

DATA VALIDATION PROCEDURE		*	Y/N	Source Document & Comments
A. INSTRUMENT CHECKS AND CALIBRATIONS				
1. Sensor output check	- before deployment			
	- routine			
	- after recovery			
2. Processing equipment check	- before deployment			
	- routine			
	- after recovery			
3. Sensor calibration curve	- manufacturer's			
	- derived			
	- applied			
B. DOCUMENTATION OF DEPLOYMENT PARAMETERS				
1. Information provided on	- location and duration of measurements			
	- instrument configuration			
	- instrument sampling scheme			
	- maintenance visits/actions			
	- external/internal influence on data			
C. AUTOMATIC QUALITY CONTROL OF DATA				
1. Raw data Q.C. tests .	~ if applicable specify			
2. Processed data Q.C. tests	- timing check	2.1.1		
	- mean level check	2.1.3a		
	~ absolute value check	2.1.3b		
	- check data in bounds	2.1.3c		
	- rate of change check	2.1.3d		
	- stationarity check	2.1.3e		
	- tidal range check	2.1.3g		
	- HW/LW time interval check	2.1.3h		
D. OCEANOGRAPHIC ASSESSMENT				
1. Assessment checks	- tidal signal	2.2.2a		
	- tidal range and chase comparisons	2.2.2b		
	- tidal rise and fall comparisons	2.2.2c		
	- short period oscillations	2.2.2c		
	- residual 'events'	2.2.2c		
	- harmonic constituents	2.2.3a		
	- mean level	2.2.3b		
	- inspection of residual time series	2.2.3c		
E. REPORTING AND DATA PRESENTATION				
1. Report	~ interim			
	- final			
2. Data presentation	- interim			
	- final			
3. Data submitted for banking				
F. MAGNETIC TAPE AND DOCUMENTATION FOR BANKING				
1. Data tape	- header information as specified			
	- data in format as specified			
	- all suspect data flagged as specified			
	- edited data qualified as specified			
2. Documentation	- standard documentation provided	3		
	- data listings provided			

NOTE: Tick Box Y/N only if specified action or check has been undertaken; otherwise leave blank

*These notes refer to relevant sections in Appendix A of 'UKOOA Recommended Procedures for Validation and Documentation of Oil Company Metocean Data

QUALITY ASSURANCE DOCUMENT FOR METEOROLOGICAL DATA SET

LOCATION	PERIOD OF MEASUREMENTS	INSTRUMENT			
DATA VALIDATION PROCEDURE	*	Y/N	Source Document & Comments		
A. INSTRUMENT CHECKS AND CALIBRATIONS					
1. Sensor output check - winds (specify others in comments)	- before deployment				
	- routine				
	- after recovery				
2. Processing equipment check - winds (specify others in comments)	- before deployment				
	- routine				
	- after recovery				
3. Sensor calibration curve - winds (specify others in comments)	- manufacturer's				
	- derived				
	- applied				
B. DOCUMENTATION OF DEPLOYMENT PARAMETERS					
1. Information provided on	- location and duration of measurements				
	- instrument configuration				
	- instrument sampling scheme				
	- maintenance visits/actions				
	- external/internal influence on data				
C. AUTOMATIC QUALITY CONTROL OF DATA					
1a. Raw data Q.C. tests (wind data)	~ timing check	2.1.1			
	- absolute value check	2.1.2			
	- stationarity check	2.1.4			
	- fluctuation check	2.1.5			
1b. Raw data Q.C. tests - other sensor data (specify)	- timing check	2.1.1			
	- absolute value check	2.1.2			
	- stability check of soot readings	2.1.2			
2a. Processed data Q.C. tests - wind data (specify)	- timing check	2.2.1			
	- checks on type of input data	2.2.2			
	- absolute value check	2.2.3a			
	- check data in bounds	2.2.3b			
	- rate of change check	2.2.4			
2b. Processed data Q.C. tests - other sensor data (specify)	- stationarity check	2.2.5			
	- timing check	~2.2.1			
	- checks on type of input data	2.2.2			
	- absolute value check	2.2.3a			
	- check data in bounds	2.2.3b			
- rate of change check	2.2.4				
	- stationarity check	2.2.5			
	D. METEOROLOGICAL ASSESSMENT				
	1. Assessment checks wind data	~ inspection of time series	2.3.2ac		
- inspection of speed/dirn distribution		2.3.2			
~ wind/pressure field correlations		2.3.2e			
~ wind climate comparisons		2.3.2d			
2. Assessment checks - other sensor data (specify)	~ inspection of time series	2.3.2a			
	- trends and 'events'	2.3.2b			
	- comparisons with other data	2.3.2d			
E. REPORTING AND DATA PRESENTATION					
1. Report	~ interim				
	- final				
2. Data presentation	~ interim				
	~ final				
3. Data submitted for banking					
F. MAGNETIC TAPE AND DOCUMENTATION FOR BANKING					
1. Data tape	~ header information as specified				
	- data in format as specified				
	~ all suspect data flagged as specified				
	~ edited data Qualified as specified				
2. Documentation	- standard documentation provided	4			
	~ data listings provided				

NOTE: Tick Box Y/N only if specified action or check has been undertaken; otherwise leave blank

*These notes refer to relevant sections in Appendix A of 'UKOOA Recommended Procedures for Validation and Documentation of Oil Company Metoccan Data

3. INSTRUMENT CHECKS AND CALIBRATIONS

3.1 INTRODUCTION

A rational approach to the checks and calibrations of instruments is required from both the data gatherer and the client, in which the intention and scope of data collection programmes are fully recognised. Moreover, the approach should be developed and applied consistently and systematically, in order that confidence is maintained in the data, and that comparisons between different data sets are not distorted by unknown variations in sensor performance. It can not be over-stressed that the data are only as good as the sensors and processing equipment which have been used to measure them, and without an adequate knowledge of sensor performance, the integrity of the data can only suffer as a consequence.

A distinction between checks and calibrations of instruments is recognised, and these are defined as:

- a) Checks comprise tests on the sensor output and processing equipment to ensure that they are functioning correctly and that they are performing within the manufacturer's specification. Calibration curves or equations which have been provided by the manufacturer are then applied to the data collected during the measurement period.
- b) Calibrations comprise tests which provide sufficient information to allow the production of calibration curves or equations for the instrument or sensor, and these curves or equations are applied to the data obtained during the measurement period.

For some instruments, particularly those measuring dynamic variables (i.e. wind speed, current speed, heave, pitch, and roll), detailed checks may be necessary to establish whether the sensors are performing within the manufacturer's specification. To calibrate (*sensu stricto*) these instruments is likely to require an effort which is beyond the requirements of the data collection programme and which would be financially prohibitive. The requirement is therefore that the manufacturer will have undertaken a calibration, and made this available to the purchaser.

For most other sensors, including those measuring sea temperature, conductivity, underwater pressure, atmospheric pressure, air temperature, relative humidity, direction, and water level, calibration is relatively simple, and should always be undertaken at least once for a given data collection programme.

Data collection programmes mainly fall into two different categories which are defined by the proposed duration of the measurements. The first are programmes of short duration which are less than about six months, and the second are programmes of longer duration, which often continue for five or more years. An approach to the frequency of instrumentation checks and calibration for each category of programme is described below; certain specific methodologies are outlined in Table 3.1.

3.2 DATA COLLECTION PROGRAMMES OF SHORT DURATION

3.2.1 Wind and Current Speed Sensors

Checks on the threshold of measurement (for mechanical sensors), or the zero offset (for acoustic and electro-magnetic sensors) should be undertaken both before deployment and after recovery of the sensor. Checks on the sensor performance over the expected range of speeds should be undertaken before deployment, unless the sensor has been checked during the previous six months and has not been deployed subsequently. These checks should ensure that the sensor is performing within the manufacturer's specification.

A full check should be carried out after recovery if it was not performed before deployment, or if there is any evidence of sensor instability or drift during the period of deployment.

3.2.2 Heave, Pitch, Roll Sensors

These sensors, together with the processing equipment used with them, should be checked both before and after deployment. The checks should include tests on the zero offset, the pitch-roll angles, and the amplitude and phase response of the heave sensor with respect to frequency.

3.2.3 Other Sensors

These include sensors for: direction, sea temperature, conductivity, underwater pressure, atmospheric pressure, air temperature, relative humidity, and water level.

Calibrations should be performed on these sensors before deployment, unless the sensor has been calibrated during the previous six months and has not been deployed subsequently.

Checks should be performed upon recovery; although a calibration should be undertaken if it was not done before deployment or there is evidence of sensor instability or drift during its deployment.

For certain sensors (e.g. water level, conductivity, atmospheric pressure), spot readings to check the calibrations should be performed as often as possible during the data collection programme, and at least at the start and the end. These '*in situ*' checks on the calibrations should be used to correct the data if a systematic offset is evident, the cause of which is identifiable.

3.3 DATA COLLECTION PROGRAMMES OF LONG DURATION

The checks and calibrations undertaken on sensors and the processing equipment should be similar to that for programmes of short duration, but with certain additions.

Full checks and calibrations should always be undertaken at the start and end of the programme, and also at regular intervals during the programme. For heave, pitch, roll, and wind and current speed sensors, the maximum interval between checks should be two years, and preferably one year; for other sensors the maximum interval between calibration should be one year, and between checks six months.

A regular maintenance schedule should be undertaken to check and monitor the sensors and processing/recording equipment. These maintenance checks should be at intervals not exceeding six months. Provisions should also be made for unscheduled maintenance which may be required due to instrument malfunction.

In addition, where possible, more frequent checks on the instrumentation should be undertaken at intervals of a month or less. These checks should incorporate simple maintenance, if necessary, and '*in situ*' measurement of the metocean variables using other means (e.g. visual observations, hand held anemometers etc.).

3.4 ADDITIONAL CONSIDERATIONS

Certain conditional aspects to these proposed requirements should be recognised:

- a) If a sensor is found to be performing outside the manufacturer's specifications during the predeployment check or calibration, it should not be deployed until the instrument has been referred back to the manufacturer, because of uncertainty in the stability of the instrument.
- b) If a sensor is found to be performing outside the manufacturer's specification during the post-deployment check or calibration then the resulting action depends on the sensor involved. For those sensors which are relatively simple to calibrate, a second calibration should be performed, if not already undertaken. The results from the two calibrations should then be interpolated linearly between the times of deployment and recovery, unless a step change is apparent in the data, indicating that the respective calibrations may be applicable systematically up to and back to the step change.

For those sensors which cannot be readily calibrated, the data should be carefully scrutinised for any indication of changes in sensor stability or the performance of the processing equipment. If no distinct change in the data is evident, or no cause of the problem is readily identifiable, then the data should be considered to be compromised, unless a calibration is undertaken.

- c) If a sensor is lost during a data collection programme, so that no post-deployment check or calibration is possible, then any data obtained should be cautioned to this effect and particular attention paid during the data validation to any indications of sensor drift or instability.
- d) If a sensor has a known characteristic behaviour under certain environmental conditions, which results in a systematic error in the data, then the nature of the expected bias and details of any corrections applied to the data should be documented.

3.5 DOCUMENTATION

All checks and calibrations undertaken on instruments should be adequately documented, and any calibration curves or equations applied to the data should be defined.

Variable	Instrument example	Check/Calibration Method
Waves several frequencies. (one-dimensional data)	Datawell Waverider	Rotation on Ferris Wheel of fixed radius at (Check)
distances. (Calibration)	Thom~EMI WHM-1	Signal measurement over several fixed
(directional data) several frequencies. Instrument free to rotate in	Datawell Wavec - heave, pitch and roll sensors - compass	Rotation on Ferris Wheel of fixed radius at cradle during Ferris Wheel rotation. (Check). Rotation about vertical axis at fixed intervals in an area where the earth's magnetic field is undisturbed. (Calibration)
Currents speeds.	Aanderaa RCM4 - speed sensors - direction (compass)	Flume or tow-tank at several flow or carriage (Check) Rotation on a swinging table in an area where
the earth's magnetic field is undisturbed.		(Calibration)
speeds.	Interocean S4 - speed sensor - direction (compass)	Flume or tow-tank at several flow or carriage (Check) Rotation on a swinging table in an area where
the earth's magnetic field is undisturbed.		(Calibration)
Water Levels	Aanderaa WLR-5	Dead-weight pressure tester. (Calibration)
	Pneumatic Bubbler	' <i>In situ</i> ' measurements of water level.
	Tide Gauge	(Calibration)
Winds	Munro IM146 - speed sensor - direction	Wind tunnel at several wind speeds. (Check) Rotation on swinging table at fixed intervals
	and ' <i>in situ</i> ' measurements for north reference.	(Calibration)

Table 3.1 Examples of Check /Calibration methods for the main metocean variables

(Note: For further details on checks and calibrations, reference is made to the manuals for the various instruments indicated, and the proceedings of a recent International Conference Advances in Underwater Technology and Offshore Engineering. Vol 4: Evaluation, Comparison and Calibration of oceanographic instruments: Proc. Intern. Conf. (Ocean Data, London 4-5 June 1985) organised by Soc. for Underwater Technology. London, Graham and Trotman.)

4. DOCUMENTATION OF DEPLOYMENT PARAMETERS

This documentation comprises information on the operational aspects of the data collection programme and includes:

- a) definition of the location of the measurements;
- b) definition of the time period of the measurements;
- c) the method of deployment of the instrumentation;
- d) the sampling scheme used for the measurements; and
- e) comments on any external or instrumental effects which may have influenced the data.

In essence, this information provides the contextual background of the data set, to assist in the quality control and oceanographic assessment of the data. Its reporting is considered in section 6.

For data collection programmes of long duration, specific attention should also be paid to changes in the deployment parameters occurring during routine or emergency maintenance visits. In addition, for any data collection programme, due consideration should be given to the monitoring of external influences during the period of measurements, since these may be temporary, but have significant effects on the data (e.g. temporary removal of a sensor during platform maintenance; or the obstruction of a sensor, or distortion of the wave/wind climate, due to the siting of a rig close to a platform).

5. QUALITY CONTROL PROCEDURES

5.1 INTRODUCTION

Quality control procedures for metocean data are considered to comprise two distinct aspects:

- a) Automatic Quality Control

Automatic quality control consists of checks on individual data points or the internal consistency of the data. These checks are mostly applied by computer and provide tests for timing errors, physical limits of the data, constant values, rates of change, and the identification of gaps.

- b) Oceanographic Assessment

Oceanographic assessment is an assessment of the oceanographic 'reasonableness' of the data set, comprising checks on expected patterns or trends and comparisons with other data sources.

Quality control procedures for the main metocean variables measured by UKOOA (waves, currents, water levels, and winds) are presented in Appendices A-D. Included in the Appendix on currents are procedures for the additional variables often measured in conjunction with current data, i.e. sea temperature, conductivity/salinity, and pressure/head of water; whilst in the Appendix on meteorological variables, procedures are also defined for the variables which usually accompany wind data, i.e. barometric pressure, relative humidity, air temperature, and sea surface temperature.

5.2 AUTOMATIC QUALITY CONTROL OF DATA

Automatic quality control procedures for each metocean variable are defined in Appendices A-D. A distinction has been made in the procedures between raw data and processed data, and checks have been defined for both types when these are available. Raw data in this context are considered to be a series of data points sampled at high frequency (of the order of 1-2Hz), which is averaged or analysed to provide values of processed data. For certain instruments, particularly current meters and water level recorders, the sensor output is often processed data, since averaging is applied to the raw data internally and no raw data are available for checking. Thus for current and water level data, only processed data checks have been defined. However, for waves and the meteorological variables, when raw data are generally available for checking, tests are presented for both raw and processed data. The

raw data tests are intended primarily to indicate any sensor malfunction, instability, or interference, in order to reduce potential corruption of the processed data.

The processed data checks are intended to identify erroneous or anomalous data, and have been formulated as a set of minimum requirements which are at the same time consistent and simple in their approach and application. These conditions to some extent conflict, as simple, universally applicable and unique tests are often too coarse in their resolution to be anything but gross error checks. Various tests are therefore defined in the Appendices which have been based on the environmental conditions generally prevailing in UK waters. These tests are intended to act as pointers to anomalous or 'out-of-the-ordinary' data, signifying that the data need investigation.

It is recognised that under certain circumstances these tests may be failed regularly, but this could be considered to indicate that the environmental conditions are more extreme than the expected average conditions for all sites, and thus notable. Conversely it may be that in other cases, more stringent site specific tests are required. In certain situations, therefore, it is accepted that the limits for these tests may need to be related more specifically to the expected environmental conditions at the measurement site, or developed from experience with the data.

No specific connotation has been placed on the time and location of the application of the quality control procedures. However, generally, raw data checks are applied at the time of data collection, while processed data checks are applied onshore in the laboratory.

5.3 OCEANOGRAPHIC ASSESSMENT

The final validation procedure applied to metocean data involves the assessment of the oceanographic 'reasonableness' of the data, together with the integration of the results of the instrumentation checks, the documented deployment parameters, and the results of the quality control tests. In what follows, a distinction is made between lower and higher levels of oceanographic assessment, depending on the extent and depth of the investigation. Procedures for both the lower and higher levels of oceanographic assessment of each metocean variable are defined in Appendices A-D.

The lower level of oceanographic assessment includes the following elements. The oceanographic reasonableness of the data is initially assessed manually, by inspecting the data set for expected patterns or trends, for example: the occurrence of a semi-diurnal tidal signal for currents and water levels; an increase in H_S and T_Z accompanying an increase in wind speed; the occurrence of a distinctive 'envelope' of H_S / T_Z values with no isolated outliers; a backing or veering of wind direction during the passage of a depression. Comparisons of the main features of the data are also usually made with any data for the same area which are readily available from other sources.

Higher level oceanographic assessment generally involves the application of further analytical methods (e.g. harmonic analysis to current and water level data), and detailed data-point by data-point comparisons with other available data. It also involves the validation of anomalous data for which the causes are not readily identifiable, and this may include the investigation of particular process-response mechanisms in the data (e.g. inertia] oscillations or internal tides in current meter data, wind speed wave height correlations, the evolution and decay of wave spectra during the passage of depressions).

It is envisaged in the context of the minimum requirements for data validation, that all oceanographic assessment should include at least the lower level checks defined in Appendices A-D. Some higher level checks should also be undertaken, if the data require them and are sufficient for them to be undertaken.

5.4 FLAGGING AND EDITING OF DATA

The scheme outlined for data flagging has been developed in relation to the quality control procedures defined in Appendices A-D, and includes elements associated with both the automatic quality control and the oceanographic assessment of the data.

The requirements for data editing have been devised to reduce the manipulation of the data set, since it is considered desirable that the final validated data set should be as close to the original as possible. A user of this validated data set may subsequently edit the data or merge the data set with another for a particular purpose, but these further actions are judgements made by the user, and should in no way influence the original data set.

a) Types of Flags

The flagging of data comprises two different elements:

- i) 'automatic' flags which are associated with the automatic quality control checks; and
- ii) 'qualifiers' which indicate the validity of the data according to the assessment of the analyst.

b) Automatic Checks

Each of the automatic quality control checks for the processed data, which are defined in Appendices A to D, should generate a flag when the check fails, and this flag should be ascribed to the data point failing the check. Each flag or combination of flags should be uniquely characterised so that all failures are readily identified with each data point, and are indicated in any listing of the data.

In addition, graphical presentations of the data, in particular time series plots, should be capable of incorporating the flags, in order to aid in the validation and editing of the data.

Raw data flags for wave and meteorological data should not be ascribed to the final validated data-set. However, a single flag indicating whether any of the raw data flags were generated should be incorporated in the processed data flags.

c) Editing

Only limited editing of the processed data should be undertaken. This limitation is imposed in order that data sets do not become 'over-massaged' or, conversely, good data are not edited out. Editing should therefore be restricted to the following:

- (i) Null values should be ascribed only to those data points failing gross limit checks or stationarity checks, or to known gaps in the data.
- (ii) Interpolation should be undertaken only for single values of null data, and is acceptable for all variables measured at sampling intervals of one hour or less, except wave height and period (HS, TZ) and wind speed and direction. Interpolation is not acceptable for any variable for which the sampling interval exceeds one hour. Interpolated data points should be determined linearly from adjacent points, and should be qualified accordingly.
- (iii) 'Infill data' should only be used when these are available at the same location, either from a different system or from a different analytical method (e.g. Hs determined by Tucker-Draper analysis of chart records as opposed to Hs determined by spectral analysis of 2Hz digital data). Any 'infill data' should be qualified accordingly. Data from a different location to the measurement site should not be used as 'infill data'; merged data sets should therefore not be submitted for banking on the NODB, except in special, and mutually agreed circumstances. This does not preclude the subsequent generation of merged data sets from several validated data sets for climatological or other studies, but these merged data sets should not be considered as primary data sources.
- (iv) If the data validation procedures reveal a systematic error in a data channel, the cause of which can be identified, then corrective editing can be undertaken on all affected data points. These corrected data shall be defined in the documentation, together with the cause and the remedial action taken.

d) Data Qualifiers

After editing of the data, investigation of any anomalous data points, and the completion of the oceanographic assessment, each data point should be ascribed with a qualifier indicating whether the data are considered to be good, bad or uncertain in the opinion of the analyst. Where the opinion of the analyst conflicts with the results of the automatic checks (i.e. data qualified as bad but no flags generated or data qualified as good where one or more checks have been failed), then reasons should be given for the qualifier attributed to the data. Qualifiers for interpolated and infilled data should not be altered by the above data quality qualifiers.

5.5 VALIDATED DATA SET

The validated data set constitutes the final processed data set which has undergone quality control, oceanographic assessment, and editing, and in which each data point has been qualified and flagged. The validated data set is the authoritative data set which is submitted to the NODB and which is also utilised in the data report submitted by the data gatherer to his client.

For multiple channel systems, the validated data set for each variable should only comprise one set of values. This set should as far as possible, be that from the sensor providing the greatest amount of valid data, and its source should be documented. Any data utilised from the other sensor(s) should be treated as 'infill' data, and qualified accordingly.

Data points which the data gatherer has qualified as other than good (i.e. bad, uncertain, nulled, interpolated, or infilled data) should be plotted and identified on time series plots. However for all statistical representations of the data (i.e. bivariate and univariate distributions) bad and null data should be omitted, and the number of uncertain, interpolated, and infilled data points should be indicated.

6 REPORTING AND DATA PRESENTATIONS

6.1 INTRODUCTION

The documentation of metocean data sets has already been considered in terms of the QADs (section 2), instrument checks and calibrations (section 3), and deployment parameters (section 4).

The reporting of metocean data collection programmes includes both these last two aspects so that further consideration is therefore given to them in section 6.2. In addition, supporting documentation for data tapes submitted to the NODB is also described in section 6.3. This documentation is defined in Appendices A-D, and specifically relates to data submitted for banking. It is thus distinct from the other documentation required for a metocean data set.

6.2 REPORTING

Due consideration is necessary in the reporting of a data collection programme to the documentation of the operational aspects, the data validation procedures, and the presentation of the data.

The operational aspects of a data gathering programme should be documented either in specific reports or within the final report, and should include information on the following

- a) instrument deployment
- b) instrument recovery
- c) maintenance visits
- d) instrument checks and calibrations

The information should be built up cumulatively and consistently, and any significant features which could affect the data should be highlighted.

In addition, for systems utilising a variety of sensors, deployed either from a buoy or a fixed platform, a descriptive system manual should also be produced which defines all components of the system, their location, and their specifications.

Final reports (or annual reports where data collection programmes extend over several years) should document all the information relating to data validation in a coherent and consistent manner, and specify or reference the quality control procedures applied to both raw and processed data. All data presentations should include sufficient information to define uniquely the data plotted. This information is in effect an abbreviated form of the series header information defined in Appendices A to D. In addition, time series plots of processed data should present data qualifiers for those data points which have been quantified as anything other than good. All other presentations should indicate the number of data points which are uncertain, infilled, or interpolated, and which have been plotted.

6.3 BANKING OF DATA

General requirements for the banking of data with the NODB are outlined below. Requirements for the provision of an archive tape for the client have not been considered, as these are likely to vary between individual UKOOA members.

Data submitted to the NODB should be accompanied by appropriate supporting documentation. This documentation is a significant aspect of the data set, since it provides all the necessary supplementary information which defines and qualifies the data, and thus influences their long-term integrity. Requirements for this documentation and the structure and format of the data tape are considered in sections A4, B3, C3 and D3 of Appendices A - D. In addition, a hard copy listing of sections of each data file, preferably the first and last 50 records, should be submitted with the documentation, as a check on the data tape.

It is recommended that initial discussions are held between the client, or his representative, and the NODB prior to submission of the data tape(s). These discussions should define the nature and volume of the data, and the proposed structure and format of the data tape. The NODB would thus be provided with time to plan and allocate its resources, and present its comments on the data tape structure and format, and any requirement for non-standard documentation. Subsequent discussions with the NODB may continue through the client, or may be held with the data gatherer.

SECTION 2.2

APPENDIX A

WAVE DATA

A1	General Discussion
A2	Quality Control of Non-Directional Wave Data
A3	Quality Control of Directional Wave Data
A4	Documentation

SECTION 2.2, APPENDIX AI: WAVE DATA

1. GENERAL DISCUSSION

1.1 NON-DIRECTIONAL WAVE DATA

1.1.1 Data collection and analysis procedures

Wave data can be recorded and processed in a number of different ways. The quality control procedures to be applied to the data are largely independent of these variations, but there are differences. The predominant methods for data collection are currently as follows:

- a) Raw digital data stored on magnetic tape for subsequent analysis in the laboratory
- b) Digital data analysed in real time to produce processed wave parameters which are stored on magnetic tape. Under these circumstances, the raw data are not usually stored, though they may be stored when the wave height exceeds a pre-determined threshold.
- c) Analogue data collected on a pen and ink strip chart, either as the sole method of data collection or as a back-up.

Digital data are usually analysed in one of two ways - spectral analysis, or time domain analysis. In either case, the quality control tests are mostly the same, except for tests on the spectrum which cannot be carried out if time domain analysis is used.

Analogue chart data are analysed using the Tucker-Draper method (see e.g. Draper 1967). The quality control procedures on the raw data are different to those applied to digital data, but those applied to the processed data are identical, again with the exception of spectral checks.

1.1.2 Automatic quality control of raw digital data

The aim is to obtain as much good quality data as possible. Some data may fail a number of tests putting their validity into question. However, rejection of data with no possibility of retrieval later is avoided as shown below. Within the philosophy adopted here, the quality control tests are divided into two categories:

- a) Tests which indicate a serious problem with the data

To ensure maximum data return, failure of any of these tests should cause not only specific flags to be set, but also a universal 'Data Error Flag' to be set. Setting of this latter flag must be taken to mean that the data are wrong unless otherwise proved. Where raw data are not routinely collected, then the setting of this flag should be accompanied by storage on magnetic tape of the unedited raw data set, such that if required at a later date the raw data can be examined and edited as necessary. The automatic calculation of wave parameters at offshore installations can proceed despite the setting of this 'Data Error Flag', except where the raw data timing test is failed - in this case no further processing takes place, and the wave parameters are all nulled.

- b) Data check tests

Failure of one of these tests causes a specific flag to be set, but no further action is taken. The flag will indicate a potential problem to the analyst at a later stage. No special storage of unedited raw data is required for failure of these tests.

In all cases, therefore, except when the raw data timing test has failed, the wave data are processed to produce wave parameters such as H_s and T_z . It is essential that the flags associated with each processed data point be clearly defined, and that they are always provided with the data to enable the oceanographer to make best use of the data. He must therefore be aware of the meaning of the 'Data Error Flag'.

1.1.3 Raw data quality control tests for analogue chart data

The quality control procedures applied to raw analogue chart data are carried out manually by the person analysing the records, though the numerical checks should also be incorporated in the software which subsequently performs the Tucker-Draper analysis.

Because analogue records are analysed manually, decisions as to their validity are made at this stage. Once a record has been rejected, usually there will be no requirement to carry out further tests, and the subsequent computer analysis should generate nulled wave parameters.

1.1.4 Automatic quality control of processed data

Processed wave data, namely the individual values of variables such as Hs and Tz are subjected to a number of tests which check that the parameters fall within certain defined limits, and that they bear the correct relationship to one another. Failure of one of these checks causes a flag to be set, indicating to the analyst that there may be a problem.

1.1.5 Oceanographic assessment

Assessment of the data for oceanographic reasonableness is the final quality control procedure. This assessment takes place at two levels, a lower and a higher. The lower level is essentially aimed at the data set as a whole rather than at individual points. However, the analyst may determine that a particular data point or series of data points is in error. Any such assessed errors should be described in the documentation which accompanies the data.

At the higher level significant 'events' or anomalous data are investigated in detail while additional checks are made on the data using further analytical methods.

1.1.6 Storage of raw data

As already mentioned, the unedited raw digital data should be stored whenever the data appear to have a serious problem. In addition, where raw digital data are stored routinely, or as a result of the wave height exceeding a set criterion, only unedited data should be stored, despite any editing which might have taken place offshore prior to the calculation of processed wave variables.

1.1.7 References

Draper, L. 1967 The Analysis and Presentation of Wave Data - A Plea for Uniformity. Proc. 10th Conf. Ctl. Engin. (Tokyo) 1966 Vol. 1, pp 1-11. New York, ASCE.

1.2 DIRECTIONAL WAVE DATA

1.2.1 Introduction

Directional wave data can be obtained using a number of widely differing measurement techniques, such as: HF radar, 2-frequency micro-wave radar, arrays of sea surface elevation monitors, measurements of wave orbital velocity, and pitch-roll buoys. The quality control of raw data is largely dependent on the method of measurement, whereas the quality control of processed data is to some extent, though not entirely, independent of the measurement technique.

The procedures outlined in this report are specifically for use with data obtained from surface following pitch-roll buoys. They were developed from discussions with J Ewing and T Pitt of the Institute of Oceanographic Sciences. A recent summary of the analysis, presentation and interpretation of directional wave data is provided by Ewing (1986).

Directional wave data obtained by surface following buoys are always recorded digitally, and analysed spectrally -there is no alternative. Hence the quantities of raw and processed data are large. The quantity of raw digital data obtained by a directional buoy per record is approximately 5 times that

obtained by a non-directional buoy, whilst the quantity of spectral information from a directional buoy is approximately 10 times that from a non-directional buoy. Very few non-directional systems currently store all the raw data, and some do not compute spectra, relying only on time domain analysis. It is not surprising, therefore, that directional buoys such as DB2 and DB3 record the raw data only once every 93 hours and that there is some discussion as to the quantities of directional spectral data which should be archived at the NODB.

1.2.2 Quality control of raw digital data

Some systems are available with 'off-the-shelf' receiving units. For example, data from the Datawell WAVEC buoy can be received on the DIREC unit, which also has the capability to process the raw data to provide the 9 cross-spectra. If this option is taken, raw data quality control is incorporated within the unit software, and a data quality status flag is output. The operator has no control over the quality control procedures used, and must accept the processed data at face value. In situations other than this, then the data gatherer is in a position to apply his own quality control procedures.

Unfortunately there is not yet a well established suite of proven quality control procedures which can be applied to raw directional wave data. Some of the tests are still experimental, and a lot more experience of their use is required before they could be regarded as generally acceptable. In fact, the whole area of quality control of directional wave data requires a considerable degree of further research. For example, the rate of change checks currently applied to DB2 and DB3 data are now believed by some experts to be inadequate.

The quality control procedures which should be applied to the three data channels - acceleration, pitch, and roll - are therefore restricted to limit checks and stationarity checks.

1.2.3 Quality control of processed data

Processed data from a pitch-roll buoy comprise primarily the 9 cross-spectra, for each of which there are perhaps 50 estimates with a bandwidth of about 0.01Hz. From these cross-spectra (three of which have zero expectation) a number of frequency dependent parameters can be derived, such as mean direction, directional spread, and check ratio which theoretically should be 1 at all frequencies.

The quality control tests that should be applied to these processed data include checks on the distribution of energy within the heave spectrum, examination of the mean direction at high frequencies to ensure that it corresponds to the wind direction, examination of the check ratios, and examination of the three cross-spectra which are expected to have values of zero.

1.2.4 Oceanographic assessment

Assessment of the data for oceanographic reasonableness is the final quality control procedure. This assessment takes place at two levels, a lower and a higher. The lower level is essentially aimed at the data set as a whole rather than at individual points. However, the analyst may determine that a particular data point or series of data points is in error. Any such assessed errors should be described in the documentation which accompanies the data.

At the higher level significant 'events' or anomalous data are investigated in detail, while additional checks are made on the data using further analytical methods.

1.2.5 Archiving of processed data on the NODB

As previously mentioned, there are nine cross-spectra which are available for archiving on the data bank, although only six of these are required in the generation of wave statistics, the remaining three theoretically having values of zero. It is recommended that all nine spectra are submitted for banking, as these redundant data may be useful for quality control in the future. Moreover, one year of 3-hourly wave spectra do not constitute a storage problem, since they can be stored on one magnetic tape.

1.2.6 References

Ewing, J. 1986. Presentation and Interpretation of Directional Wave Data. Underwater Technology, Vol 12, No 3, pp 17-23.

SECTION 2.2, APPENDIX A2: WAVE DATA

2. QUALITY CONTROL OF NON-DIRECTIONAL WAVE DATA

2.1 RAW DATA QUALITY CONTROL TESTS (DIGITAL OR DIGITISED DATA)

2.1.1 Raw data timing

Check $R_d = R_e$

where R_d is number of digital raw data values collected

R_e is number of digital raw data values expected as calculated from sampling period and sampling rate.

Failure of this test causes the 'Data Error Flag' to be set and the unedited raw data to be stored. No further processing can take place, and all wave parameters are nulled.

2.1.2 Checks resulting in interpolation

Failure of one of the following tests on an individual data point requires it to be replaced by an interpolated value. The number of interpolations allowed is based on a record length of 1024 seconds sampled at 2 Hz. For other record lengths, the allowable number of interpolations should be determined on a pro rata basis.

Where the test indicates that two or more consecutive points require interpolation, then a flag should be incremented for each interpolated point which is preceded by an interpolated point. Under these latter circumstances, the unedited raw data should be stored, and the 'Data Error Flag' should be set. Further processing may then proceed.

a) Gross error limit

Test for values greater than 6 times standard deviation from the mean

b) Rate of change check

The maximum allowable elevation difference between adjacent samples, G_{max} , is given by:

$$\Delta C_{MAX} = \left[\sigma S_{MAX} \pi \left(\log_e \left(\frac{T \sqrt{g S_{MAX}}}{8 \pi \sigma} \right) \right) \right]^2 \cdot \Delta t$$

where σ is standard deviation

S_{max} is max allowable wave steepness

T is record length

Δt is sampling interval

Interpolation to be carried out on second point to remove single spikes if ΔG_{max} exceeds the computed value.

Flags should be raised to show the number of interpolations arising from each test, and the 'Data Error Flag' should be set and the un-edited raw data should be stored if the total number of interpolations exceeds 10.

Checks a) and b) above cannot be performed until the mean level and standard deviation have been calculated. If any interpolations are necessary due to subsequent failure of checks a) or b) then the mean level and standard deviation should be re-calculated after interpolation, and prior to the remaining checks.

2.1.3 Checks not requiring interpolation

Failure of any of the following checks does not cause the data to be corrected by interpolation. Flags are incremented by each failure of these checks; action to be taken is dependent on the check.

a) Consecutive equal values

Test for occurrence of 10 or more consecutive points with equal value - 'Data Error Flag' set and unedited raw data stored for one (or more) occurrence.

b) Wandering mean check

Test for individual zero up-crossing period of > 25 seconds - 'Data Error Flag' set and unedited raw data stored for one (or more) occurrence.

c) Data stability check

The wave sample is divided into 8 equal segments. The mean and standard deviation of each segment are calculated and compared to the mean and standard deviation of the entire sample. A 'Data Error Flag' should be set, and the unedited raw data stored, if the means or standard deviations of the segments differ from the mean or standard deviation of the entire sample by the following:

- difference in means $> \pm 0.20$ m.
- difference in standard deviations $> \pm 0.25$ m or $> \pm 20\%$ of the standard deviation of the entire sample, whichever is the greater.

The stability check on the mean level, as described above, is not directly applicable to wave measuring systems which use a fixed structure as a reference, due to the possible effects of tide; a less rigorous permitted variation in the mean may then be substituted.

d) Check limits

Test for values greater than 4 times standard deviation from the mean - 'Data Error Flag' set and unedited raw data stored for 8 or more occurrences.

2.1.4 Raw Data Inspection and Editing

It is good practice to inspect visually a small proportion of the raw digital data records, including those for which no flags have been set, as a final check on the quality of the raw data. In addition to this random inspection which should be regarded as routine, it may be necessary to inspect any critical records which have been rejected by the automatic raw data quality control procedures, and which have the 'Data Error Flag' set. From this inspection, it may be evident that a certain section of the record is invalid, and that by editing the digital data record a valid analysis can proceed. Where this is done, a unique flag should be set, and a detailed description given in the documentation.

The routine inspection of the raw data should be one of the first checks carried out on receipt of the data from offshore, whereas the inspection of specific records may become necessary at any stage of the analysis and quality control procedure.

2.2 RAW DATA QUALITY CONTROL TESTS (ANALOGUE CHART DATA)

2.2.1 Timing

Ensure horizontal time scale of chart is well documented, and that no changes have been made without appropriate annotation. Where length of record analysed is less than the standard 20 minutes, this should be noted, and any samples with less than 10 minutes of usable record should be rejected.

2.2.2 Calibration

The calibration of analogue chart records is a particular problem, and if possible a test signal of known input voltage should be inserted at the beginning of each record. This serves the dual purpose of providing a record by record calibration and of assisting in delineating the individual records.

2.2.3 Checks

- a) Check for system malfunction, such as wandering means or truncation of peak values
- b) Where a record contains spikes, such as those caused by radio interference or poor transmission, reject the record if the spikes are expected to significantly alter the determination of any of the parameters N_z , N_c , A, B, C, and D.
- c) Check $N_c \geq N_z$
Check $A \geq B$
Check $C \geq D$

where N_z is the number of zero up-crossings
 N_c is the number of wave crests
A and B are the heights of the highest and second

highest peaks relative to the mean level
and C and D are the depths of the lowest and second lowest troughs relative to the mean level (measured positively downwards).

2.2.4 Gaps

Any gaps in the chart record should be identified, and if these affect the duration over which the data are analysed, then this should be noted.

2.3 PROCESSED DATA QUALITY CONTROL TESTS

2.3.1 Processed data timing

Check $N_d = N_e$

where N_d is the number of records in the data set
 N_e is the number of records expected from that deployment or tape

Failure of this test would indicate that manual intervention is required to ascertain the source of the problem.

2.3.2 Checks on input data

Check that pressure data have been corrected for the influence of wave attenuation with depth.

2.3.3 Checks on the spectra

The following checks should be made on the energy distribution within the individual spectra, where applicable:

- a) the energy in the spectrum at frequencies below 0.04 Hz should not be more than 5% of the total spectral energy
- b) the energy in the spectrum at frequencies above 0.6 Hz should not be more than 5% of the total spectral energy

A unique flag should be set if one or both of these conditions is not fulfilled.

2.3.4 Check limits

A flag should be set if any one of the following conditions is not fulfilled. This flag could take a value between 1 and 9 which would give some, though not totally unique, indication of which test or combination of tests failed.

- a) $0 \leq H_S \leq H_{Smax}$ (set equal to estimated 1-month return value)
- b) $H_S \leq H_{max} / 2.5$
- c) $2 \leq T_Z \leq 16$
- d) $3 < T_{peak} \leq 20$
- e) $T_Z \geq T_C$
- f) $T_{peak} \geq T_Z$

where H_S is the significant wave height

H_{max} is the measured maximum wave height

T_{peak} is the period corresponding to the frequency band containing the maximum energy

T_Z is the zero up-crossing period

T_C is the average crest period

2.3.5 Wave steepness

A unique flag should be set if the values of H_S / T_Z^2 exceeds the following condition, indicating that manual inspection of the data is required:

$$H_S / T_Z^2 > 0.22 \text{ (wave steepness } > 1 / 7 \text{)}$$

2.3.6 Stationarity

Significant wave height may be constant for more than two consecutive measurement periods if the values have coarse increments (e.g. 0.1 m) and if calm conditions prevail. Constant values of T_Z are less likely.

A flag should be set for every record for which H_S or T_Z is the same as for the previous two records, indicating that further manual inspection of the data is required.

2.3.7 Gaps

Checks for gaps in the data should ensure that any defined periods of gaps are consistent with the number of data points nulled or absent.

2.4 OCEANOGRAPHIC ASSESSMENT

2.4.1 Introduction

Manual oceanographic assessment of wave data takes place at two levels: a 'lower' level and a 'higher' level. At the lower level, which is considered to be the minimum requirement for data validation, simple checks are performed to ensure that the data are internally consistent and reasonable. At the higher level, more sophisticated checks can be made, such as investigating the relationship between wind speed and wave height, or looking at individual spectra during the passage of a storm.

2.4.2 Lower Level

Where a record has been flagged at both raw and processed stages this is a strong indication that there may be an error. However the absence of flags does not necessarily prove that a record is valid. Visual inspection of presentations such as time series and scatter plots is an essential part of the quality control process. Consideration should be given, as a minimum, to:

- a) General appearance of time series plots. This is very important for highlighting errors not picked up by the automatic quality control, such as small spikes and step functions. However, care must be taken to ensure that real data which may appear as small spikes are not qualified as bad. For 3-hourly wave data, especially at coastal sites, it is possible for conditions to generate rapid changes in H_s and T_z which can appear as small spikes.

It should also be noted that high sea-states are generally short-lived and 'peaky', that zero crossing period should be correlated to a fair degree with wave height, and that peak period can be extremely erratic for low wave heights, oscillating between short and long periods as wind seas and swells gain and regain dominance.

- b) The scatter plot of H_s against T_z should look 'normal', unless the quantity of data is small, e.g. one month or less. All points should lie within a well defined envelope, particularly on the high steepness side of the plot, and there should be no marked holes which cannot be accounted for statistically.
- c) If wind speed data are available from the same site, then simple checks on the relationship between wave height and period and wind velocity can be useful:
 - i) abrupt changes in wave height or period should correlate with wind changes
 - ii) low waves with high winds - check wind direction and duration.
- d) Available wave data from nearby sites should be used to establish whether the data recorded conform with the general climate.
- e) A few spectra (if available) should be inspected to ensure that the instrument appears to be performing correctly. For example, the nature of the spectra at high frequencies should be consistent with the expected form of wave spectra in this region (i.e. proportional to approximately frequency⁻⁵).

2.4.3 Higher Level

At the higher level, the following might be considered:

- a) During events of great interest, such as the occurrence of extreme wave heights, or when the data appear anomalous for no readily identifiable reason, confirmation of their validity might be made by:
 - i) evaluating the growth and decay of the wave field with respect to synoptic charts of wind speed;
 - ii) comparing the time series data with those from a neighbouring site;

- iii) comparing the data with the output from the Meteorological Office wave model, if no local data are available.
- b) The wind speed wave height relationship can be examined in detail; plots of wave height against wind speed for each wind directional sector may not only be interesting in their own right, but may reveal deficiencies in either the wind or wave measurements.
- c) A more detailed look at individual spectra, examining the changes which occur as a storm approaches and then passes, or checking for evidence of swell during periods of offshore or light winds. Spectra during storm conditions should be compared with theoretical spectra, such as JONSWAP or Pierson-Moskowitz.

2.5 FLOW DIAGRAM

A flow diagram illustrating the quality control procedures for non-directional wave data is presented as Figure A1.

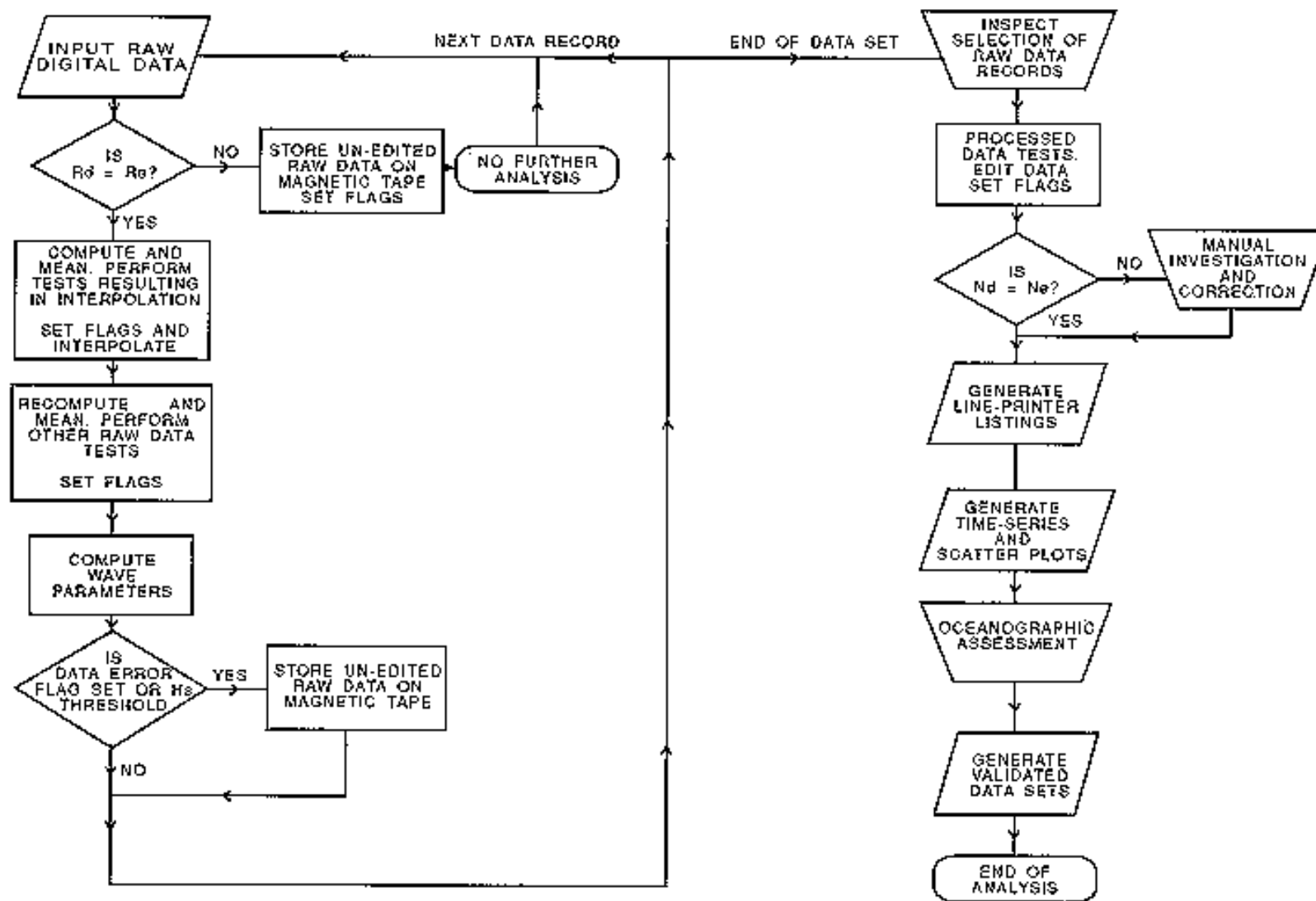

Figure A1

Flow Diagram of Quality Control Procedures for non-Directional Wave Data

SECTION 2.2, APPENDIX A3: WAVE DATA

3. QUALITY CONTROL OF DIRECTIONAL WAVE DATA.

3.1 RAW DATA QUALITY CONTROL TESTS (PITCH-ROLL BUOYS)

3.1.1 Introduction

As instrumentation increases in complexity, it becomes difficult to generalise on the procedures for analysis and quality control. This is particularly true for systems which collect directional wave data. The procedures presented in this Appendix are limited to pitch-roll buoys, but even these are sufficiently diverse to warrant varying procedures.

As mentioned in Appendix AI the data transmitted by the Datawell WAVEC buoy can be received on the DIREC unit, which applies automatic quality control checks and processes the data to provide 9 cross-spectra. The buoy has a 3-axis flux-gate compass which is fixed relative to the buoy, and hence is subjected to the pitch and roll of the buoy. Thus, to convert the measurements in the buoy's frame of reference to a fixed frame of reference, all 3 compass channels and pitch and roll are required. By calculating the absolute magnitude and inclination of the earth's magnetic field, and comparing this to the average value, it is possible to confirm either that all five channels are performing correctly, or that at least one is incorrect. In the latter case, all five channels are rejected, and if possible interpolated.

This check is not possible on other buoys such as DB2 and DB3 because they do not have the same compass system. To some extent, therefore, quality control of the raw digital data is dependent on the actual system in use, and any procedures described are really guidelines as to the kinds of quality control which should be applied.

3.1.2 Raw data timing

Check $R_d = R_e$

where R_d is the number of digital raw data values collected

R_e is the number of digital raw data values expected as calculated from sampling period and sampling rate.

Failure of this test causes a specific flag to be raised; however, processing should proceed, since the raw data channels are to be analysed in a number of sub-series, and these will not all be affected by a shortage of data. However, the flag may indicate that a timing error has resulted in an error in sampling interval, which would have serious consequences.

3.1.3 Gross error limits

Tests should be undertaken on acceleration, pitch, and roll.

The theoretical maximum acceleration in a Stokes wave is 0.5 g, whilst the theoretical maximum pitch or roll is 30° from the horizontal. Gross error limits would have to be set at or above these values, but it is not possible to recommend precise values until further research has been carried out, or operational experience gained.

A further gross limit check would be to test for values greater than 6 times standard deviation from the mean.

Failure of any gross limit checks would result in interpolation for single points, and a flag (unique to each channel) should be incremented for each failure.

Where sub-series of the data set are checked and analysed separately, then any sub-series with more than a specified number of interpolations (typically five) should be rejected.

3.1.4 Check limits

Acceleration, pitch, and roll should all be checked for deviations from the mean greater than 4 times standard deviation. The mean and standard deviation should be calculated after performing any interpolation, and ignoring any gaps (see Section 3.1.8).

The number of failures of this test permissible is dependent on the length of record. Where the record is divided into sub-series prior to analysis, then each sub-series should be permitted only a proportional number of failures, typically five for 256 sample sub-series.

3.1.5 Rate of change checks

Until further research is carried out, it is not possible to define meaningful rate of change checks on acceleration, pitch, and roll. The checks currently performed on DB2 and DB3 data are not believed to be successful.

3.1.6 Stationarity

All channels should be checked for 10 or more consecutive points with equal value. Any occurrence should result in a flag being raised, and the data sub-series containing the error should be rejected.

3.1.7 Buoy heading,

Buoy heading directions should be checked to ensure that the values lie between 000° and 360°.

3.1.8 Gaps

A very limited number of gaps (more than one consecutive bad point) can be accepted within one sub-series, otherwise that sub-series should be rejected.

3.2 PROCESSED DATA QUALITY CONTROL TESTS

3.2.1 Processed data timing

Check $N_d = N_e$

where N_d is the number of records in the data set

N_e is the number of records expected from that deployment or tape.

Failure of this test would indicate that manual intervention is required to ascertain the source of the problem.

3.2.2 Checks on input data

- i) Are direction data in degrees true or magnetic?
- ii) Does magnetic correction applied lie between 0°W and 16°W?

3.2.3 Checks on the heave spectra

The following checks should be made on the energy distribution within the individual spectra.

- a) the energy in the spectrum at frequencies below 0.04 Hz should not be more than 5% of the total spectral energy
- b) the energy in the spectrum at frequencies above 0.6 Hz should not be more than 5% of the total spectral energy.

A unique flag should be set if one or both of these conditions is not fulfilled.

3.2.4 Checks on the cross-spectra

a) Check ratio

The check ratio R is defined as

$$R = \left(\frac{1}{\tanh kh} \right) \cdot \left(\frac{C_{11}}{C_{22} + C_{33}} \right)^{0.5}$$

where C_{11} , C_{22} , and C_{33} are the acceleration, slope, and roll co-spectra
 k is the wave number, and
 h is the water depth.

This check ratio should theoretically be 1 at all frequencies, but tends to deviate substantially from that value at periods longer than the peak frequency, and at short periods outside the response range of the buoy.

The check ratio R should be computed at the peak wave energy period and at a short period (but within the surface-following capability of the buoy).

The check ratio at these two frequencies should be tested for values outside the range 0.9 to 1.1, which should be flagged. These check ratios should be stored along with the data for further checking and analysis.

b) C_{12} , C_{13} , C_{23}

C_{12} is the covariance between acceleration and pitch

C_{13} is the covariance between acceleration and roll

C_{23} is the quad-variance between pitch and roll.

Each of the above cross-spectra have zero expectation at all frequencies. In reality, each should be at least an order of magnitude less than its associated co- or quad-spectrum.

i.e.

$$\begin{aligned} C_{12}/C_{12} &\leq 0.1 \\ C_{13}/C_{13} &\leq 0.1 \\ C_{23}/C_{23} &\leq 0.1 \end{aligned}$$

These ratios should be computed at the peak wave energy period and at a short period, as for the check ratio. Due to the variability of the individual estimates, they should be computed over five adjacent spectral bands (i.e. over a spectral width of about 0.05 Hz).

These ratios should be checked for values in excess of 0.1, which should be flagged.

3.2.5 Wave Direction

a) Mean direction

Check that all values of mean wave direction (determined at whatever frequency) lie between 000° and 360°.

Any data points for which this does not apply should be flagged.

b) Directional spread

For a wind sea, the rms spread about the mean direction, θ_2 , is a minimum (about 20°) at the spectral peak, increasing at lower and higher frequencies to say 40° or 50°. For a swell, the spread will be narrower. θ_2 is very sensitive to instrument errors and noise, so it makes a useful check.

Test θ_2 at the spectral peak and flag any values greater than 30°.

3.2.6 Wave Height and Period

For the one-dimensional wave height and period data, the tests outlined in sections 2.3.3 to 2.3.5 of Appendix A2 should be applied.

3.2.7 Buoy Heading

The range of buoy heading allowable is dependent on the type of mooring. In general, the buoy heading directions should lie between 000° and 360°. However, where the buoy has a three-point mooring, then its heading is fairly restricted, and a smaller directional range can be determined and used as check limits.

3.2.8 Gaps

Checks for gaps in the data should ensure that any defined periods of gaps are consistent with the number of data points nulled or absent.

3.3 OCEANOGRAPHIC ASSESSMENT

3.3.1 Introduction

The lower and higher levels of oceanographic assessment described in Appendix A2, Section 2.4 should be applied to the heave data. In addition, certain checks should be undertaken to ensure the quality of the directional data. These checks are predominantly the visual inspection of time-series or bi-variate plots, and some of them are similar to the checks on the processed data described above.

3.3.2 Lower Level

Lower level checks on the directional data should include:

- a) When local wind data are available, time series of wind direction and the high frequency mean wave direction (θ_1) should be compared for consistency. In general, the mean wave direction should lie within 15° of the wind direction. However large differences between the two can occur when wind direction is changing rapidly, since the change in wave direction will lag behind that in the wind direction.
- b) θ_2 , the rms spread about the mean direction, should be plotted against frequency for a few selected records to check that θ_2 is a minimum at frequencies near the spectral peak and increases with frequency. θ_2 is very sensitive to instrument errors and noise.
- c) A time series of the check ratio R at the peak energy period should be plotted and inspected. As described earlier, the value of R should lie between 0.9 and 1.1, but it is affected by currents, and hence any deviations from this may show a tidal frequency.

3.3.3 Higher Level

At the higher level the following might be considered:

- a) A bivariate (scatter) plot of number of occurrences of wave height against wave direction should provide useful information, particularly if it can be examined in conjunction with a similar plot of wind speed against wind direction. However, factors such as the fetch from each direction would need to be considered.
- b) For events of significant interest, such as the occurrence of extreme wave heights, or when data appear anomalous for no identifiable reason, the directional distribution of energy with frequency could be investigated in conjunction with synoptic wind field data and any other available wave data from neighbouring sites.

3.4 FLOW DIAGRAM

A flow diagram illustrating the quality control procedures for directional wave data is presented as Figure A2.

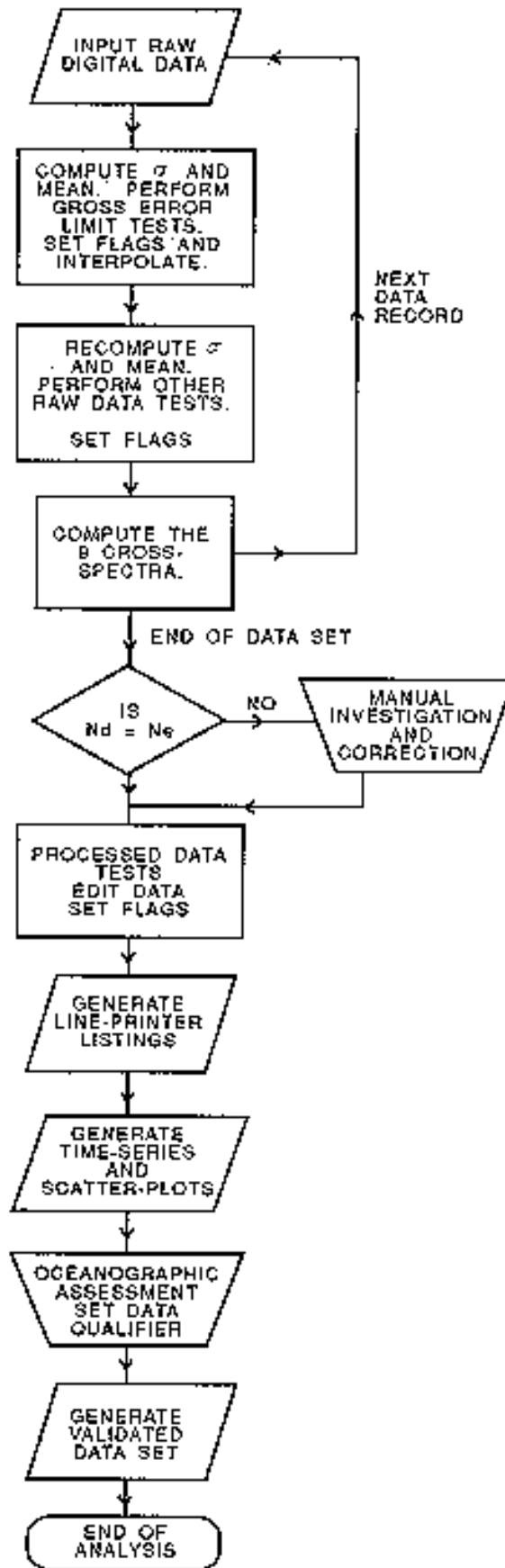

Figure A2 Flow Diagram of Quality Control Procedures for Directional Wave Data

SECTION 2.2, APPENDIX A4: WAVE DATA

4. DOCUMENTATION

4.1 This form should accompany any tape of wave data which is submitted to the NODB for banking. The following notes provide some background information to the form:

4.2 DATA STANDARDS

Before data are submitted for banking it is expected that:

- a) all relevant corrections have been applied to the data
- b) all data are expressed in oceanographic terms and in SI units which should be clearly defined
- c) the data have been fully checked for quality and pre-edited for errors such as spikes and constant values
- d) sufficient series header information and documentation are collated with the data so that they can be used with confidence by scientists /engineers other than those responsible for its original collection, processing, and quality control.

4.3 FORMATS

Data should be submitted on 9 track digital magnetic tape in a character form (e.g. BCD, ASCII, EBCDIC, ICL tape code). The tape should be unlabelled with no control words. Details of the format should be fully specified and each individual field, together with its units, clearly defined.

4.4 DOCUMENTATION

The documentation items defined in the form, which relate directly to standard instrumentation procedures, techniques etc. in operation at the originating laboratory, need only be described and submitted to the NODB once. Subsequent data should reference the standard documentation, highlighting any modifications and including those items that relate specifically to the data.

WAVE DATA

1. SERIES HEADER INFORMATION

1. SOURCE RESPONSIBLE FOR DATA COLLECTION
2. SOURCE RESPONSIBLE FOR PROCESSING AND QUALITY CONTROL (IF DIFFERENT FROM 1
3. FOR WHOM DATA COLLECTED
4. RESTRICTIONS ON USE OF DATA
5. COLLECTOR'S WAVE MEASUREMENT SITE NAME AND REFERENCE NUMBER
6. LATITUDE AND LONGITUDE OF WAVE RECORDER
7. a) MEAN WATER DEPTH b) MEAN SPRING TIDAL RANGE AT LOCATION (IF KNOWN) c) APPROXIMATE MAXIMUM CURRENTS (IF KNOWN)
8. INSTRUMENT TYPE AND SERIAL NUMBER
9. a) WAVE PARAMETERS MEASURED (E.G. HEAVE, PITCH, ROLL, BUOY HEADING) b) OTHER PARAMETERS MEASURED AT SAME LOCATION (E.G. WIND, CURRENT)

10.	DIRECTIONAL DATA
a)	ARE DIRECTION DATA IN DECREES TRUE OR MAGNETIC?
b)	MAGNETIC CORRECTION USED (IF ANY)
11.	PRESSURE RECORDERS
a)	DEPTH OF METER BELOW MEAN SEA LEVEL
b)	ARE PRESSURE DATA CONVERTED TO HEAD OF WATER
c)	IF CONVERTED TO HEAD OF WATER, GIVE VALUE OF RHO (SEA WATER DENSITY) USED
d)	IF CONVERTED TO HEAD OF WATER, GIVE VALUE OF ACCELERATION DUE TO GRAVITY USED
e)	HAVE HYDRODYNAMIC CORRECTIONS BEEN APPLIED? SPECIFY METHOD USED
12.	SAMPLING
a)	ARE DATA ANALOGUE OR DIGITAL? IF DIGITAL, GIVE SAMPLING RATE
b)	SAMPLING PERIOD AND INTERVAL
c)	IF SPECTRAL ANALYSIS PERFORMED GIVE NUMBER OF ESTIMATES OBTAINED, THEIR CENTRAL FREQUENCIES AND BANDWIDTH, AND DURATION OF SAMPLE USED FOR ANALYSIS
13.	HEIGHT OF INSTRUMENT ABOVE/BELOW MEAN SEA LEVEL (WHERE APPLICABLE)
14.	TIME ZONE
15.	a) USABLE DATA START DATE AND TIME
b)	USABLE DATA END DATE AND TIME
16.	a) NUMBER OF DATA CYCLES (FOR EACH PARAMETER)
b)	DATA RETURN BASED ON USABLE DATA PERIOD GIVEN ABOVE

2. DOCUMENTATION

A. GENERAL

A.1 REASON FOR DATA COLLECTION

A.2 INDICATE IF THE DATA SERIES FORMS PART OF

a) A MULTI-LOCATION EXPERIMENT

b) A SERIES OF LONG DURATION

B. INSTRUMENTATION

B.1 a) TYPE OF WAVE MEASUREMENT DEVICE

b) MODIFICATIONS AND THEIR EFFECT ON THE DATA

c) GIVE DETAILS OF THE INDIVIDUAL SENSORS (WHERE APPLICABLE)

B.2 GIVE DETAILS OF CHECKS AND CALIBRATION METHODS, CHECK/CALIBRATION DATES, AND CALIBRATION EQUATIONS OR CURVES APPLIED TO THE DATA (DEFINE WHETHER THOSE USED WERE MEASURED OR MANUFACTURERS).

B.3 INSTRUMENT PERFORMANCE (INCLUDING CONDITION ON RECOVERY, ANY NOTED MALFUNCTIONS, ANY EVENTS WHICH MIGHT HAVE AFFECTED THE DATA)

B.4 STEPS TAKEN TO CONTROL BIOLOGICAL FOULING

B.5 GIVE DETAILS OF THE DATA RECORDING EQUIPMENT AND MEDIUM

C. MOORING/SITE

C.1 BRIEF DESCRIPTION OF THE INSTRUMENT MOORING OR PLATFORM, AND ANY DETAILS RELEVANT IN INTERPRETING THE RESULTS

C.2 DETAILS OF STRUCTURES, OBSTRUCTIONS, OR SEA BED TOPOGRAPHY WHICH MAY HAVE AFFECTED THE DATA

D. DATA SAMPLING AND PROCESSING

D.1.. DESCRIBE THE PROCESSING PERFORMED, INCLUDING THE METHOD OF SPECTRAL ANALYSIS IF APPLIED, AND INDICATE WHETHER THE RAW DATA ARE AVAILABLE. DEFINE ALL VARIABLES WHICH HAVE BEEN MEASURED OR COMPUTED.

D.2 QUALITY CONTROL PROCEDURES AND FLAGS

GIVE DETAILS OF QUALITY CONTROL PROCEDURES WHICH HAVE BEEN CARRIED OUT ON THE RAW AND PROCESSED DATA FOR EACH VARIABLE. DEFINE EACH OF THE QUALITY CONTROL FLAGS WHICH ACCOMPANY THE DATA.

D.3 DATA EDITING PROCEDURES

GIVE DETAILS OF ANY DATA EDITING PROCEDURES WHICH HAVE BEEN CARRIED OUT ON THE RAW AND PROCESSED DATA.

D.4 DATA QUALITY

GIVE ANY INFORMATION ON DATA QUALITY INCLUDING GENERAL COMMENTS, DETAILS OF ANY KNOWN ERRORS OR UNCERTAINTIES IN DATA, AND INFORMATION AS TO WHETHER THESE ERRORS AND UNCERTAINTIES ARE FLAGGED.

D.5 OCEANOGRAPHIC ASSESSMENT

GIVE BRIEF DETAILS OF THE OCEANOGRAPHIC ASSESSMENT WHICH HAS BEEN PERFORMED ON THE DATA

D.6 ADDITIONAL COMMENTS, INCLUDING ANY ITEMS AFFECTING DATA OR HAVING A BEARING ON SUBSEQUENT USE OF DATA.

SECTION 2.2

APPENDIX B

CURRENT METER DATA

B1	General Discussion
B2	Quality Control of Current Meter Data
B3	Documentation

SECTION 2.2, APPENDIX B1: CURRENT METER DATA

1. GENERAL DISCUSSION

1.1 DATA COLLECTION PROCEDURES

Conventionally, current meter data are recorded internally, either on magnetic tape or in solid state memory, by a self-contained recording current meter, for analysis after retrieval of the current meter. In these cases, quality control procedures are limited to tests on the 'processed' data (e.g. the 10~minute mean current speed and direction) carried out back in the laboratory.

In some cases, the 'processed' values are also relayed in 'real-time' to the surface via cable or acoustic link, where they are used for operational purposes. In these cases, the data to be banked will be those recorded internally by the current meter, and any quality control which it is felt necessary to perform on the real-time data is not relevant to the banking of the data.

Increasing use is now being made of acoustic doppler current profilers. These instruments are able to measure current velocity within a large number of discrete 'bins' throughout the water column. At present, the processed data from these are generally considered in the same way as a mooring containing conventional current meters. The validation procedures defined in Appendix B2 should apply to the processed data derived for each discrete section of the water column. Consideration, whenever possible, should be given to the quality control of ADCP raw data but there are, as yet, no established procedures for this.

Many current meters carry sensors other than current speed and direction. The data recorded by these sensors will be processed at the same time as the current data, and will ultimately be banked alongside the current data. Quality control procedures are therefore given here for the additional variables pressure/depth, temperature, and conductivity/ salinity.

1.2 GENERAL QUALITY CONTROL PROCEDURES

Checks are made to ensure that no doubt exists with regard to units and corrections. This includes determining whether the current direction is in degrees true or magnetic, whether the pressure data have been converted to head of water, and whether pressure data have been corrected for atmospheric pressure.

1.3 AUTOMATIC QUALITY CONTROL OF PROCESSED DATA

Automatic quality control of processed data comprises a number of tests on the output time series data which include:

- a) data limit tests
- b) rate of change tests,
- c) stationarity tests,
- d) tidal current speed range test, and
- c) time of maximum and minimum , tidal current speed test

Failure of one, of these tests causes a flag to be set, but this does not necessarily indicate that the data point is invalid, merely that further investigation is required.

It should be noted that some of the values used in the automatic quality control procedures are based on the environmental conditions generally prevailing in UK waters, while others require the input of site-specific data for the location of the measurements. It is recognised that the values based on the general conditions may be exceeded regularly at certain sites, and due consideration should be given to this when using the procedures; the values stated are provided as guidelines for general application.

1.4 OCEANOGRAPHIC ASSESSMENT

Manual oceanographic assessment of the current velocity data takes place at two levels: a 'lower' level and a 'higher' level. At the lower level, which is considered to be the minimum, simple checks are performed to ensure that the current regime and the tidal signal are consistent with available data. This assessment is essentially aimed at the data set as a whole rather than at individual points. However, the analyst may determine that a particular data point or series of points is in error. Any such assessed errors should be described in the documentation which accompanies the data.

At the higher level, significant 'events' or anomalous data are investigated in detail, while additional checks are made on the data based on the results of harmonic analysis.

Any interpolations made in the validated data set for the purpose of higher level analysis (particularly harmonic analysis) should be documented with the results of this analysis.

SECTION 2.2, APPENDIX B2: CURRENT METER DATA

2. QUALITY CONTROL OF CURRENT METER DATA

2.1 PROCESSED DATA QUALITY CONTROL TESTS

2.1.1 Input requirements for tests

Some of the tests to be performed on the processed data require prior knowledge of the following:

HAT and LAT Minimum neap tidal current speed range Maximum spring tidal current speed range

In many cases these will be limited to an estimate based on local knowledge or obtained from available data on currents and tides (e.g. Admiralty co-tidal charts for HAT and LAT, IOS Continental Shelf Model data). The data used and their source should be documented with the results of the checks.

2.1.2 Overall Timing

- a) Check $N_d = N_e$

where N_d is the number of records in the data set

N_e is the number of records expected from the deployment period

- b) Check if sampling interval has been altered to take account of clock drift during the measurement programme.

2.1.3 Checks on input data

- a) Direction

i) Are data in degrees true or magnetic?

ii) Does the magnetic correction applied lie between 0°W and 16°W?

- b) Pressure/Head of Water

i) Are data converted to head of water?

ii) Does density used to correct to head of water lie between 1000 and 1030 kg/M³?

2.1.4 Data limit tests

a) Gross error limits

i) Current speed

Current speeds should not exceed the maximum speed which the current meter can measure based on the sampling period and scaling factor used, or 4 m/s, whichever is the smaller. The minimum current speed should be 0 m/s.

ii) Current direction

All current directions should lie between 000° and 360°.

iii) Temperature

All temperatures should lie within the range of the sensor.

iv) Conductivity/Salinity

All conductivity values should lie within the range of the sensor.

All computed salinity values should lie between 0 ppt and 36 ppt.

v) Pressure/Head of Water

The head of water determined from the pressure data should lie between 0 and the maximum water depth, which is taken to be the water depth at HAT + 2 m.

b) Check limits

i) Current speed

The upper check limit for current speeds is 1.25 times the mean spring tidal current speed.

ii) Temperature

The check limits for temperature are 0° C and 20° C.

iii) Conductivity/Salinity

The check limits for salinity are 20.0 ppt and 35.5 ppt.

iv) Pressure/Head of Water

The check limits for head of water are based on the maximum tidal range and the, assumed meter depth with some allowance for knock-down. (LAT above meter level \leq head of water \leq (HAT above meter level + 1.0 m))

2.1.5 Rate of Change Checks

Failure of a rate of change test should result in the setting of a flag, which is ascribed to the second data point in the algorithm, i.e. to T₂, S₂, etc.

a) Current speed and direction

Rate of change checks for current speed and direction are best applied to orthogonal components of the current velocity, since these can be considered to be cosine functions with definable expected differences between sampling points.

The theoretical differences between two consecutive current speed samples u_1 and u_2 for various sampling intervals (Δt) assuming a smooth sinusoidal semi-diurnal tidal current with a period of 12.42 hours are given below:

$\Delta t(\text{min})$	theoretical $ u_1 - u_2 $	factor	allowable $ u_1 - u_2 $
5	0.0422 u	2.0	0.08 m/s
10	0.0843 u	1.8	0.15 m/s
15	0.1264 u	1.6	0.20 m/s
20	0.1685 u	1.5	0.25 m/s
30	0.2523 u	1.4	0.35 m/s
60	0.5001 u	1.2	0.60 m/s

where u is the orthogonal tidal current amplitude.

In order to allow for some inherent variability in current speed and direction signal and for asymmetric tidal current speed curves, these differences have been increased by the above factors whilst u has been set at 1.0 m/s since the variability will increase with decreasing u .

The resulting allowable maximum difference between samples for particular sampling intervals are provided above.

b) Sea Temperature

$$|T_1 - T_2| \leq \Delta t / 60^\circ C$$

where T_1 and T_2 are consecutive temperature measurements and Δt is the sampling interval in minutes.

c) Conductivity/Salinity

$$|S_1 - S_2| \leq \Delta t / 60^\circ ppt$$

where S_1 and S_2 are consecutive salinity measurements and Δt is the sampling interval in minutes.

d) Pressure/Head of Water

The theoretical differences between consecutive samples h_1 and h_2 for various sampling rates Δt , assuming a semi-diurnal period of 12.42 hours are given below:

$\Delta t (\text{min})$	theoretical $ h_1 - h_2 $	allowable $ h_1 - h_2 $
5	0.0422 A	0.03 (HAT-LAT)
10	0.0843 A	0.05 (HAT-LAT)
15	0.1264 A	0.08 (HAT-LAT)
20	0.1685 A	0.10 (HAT-LAT)
30	0.2523 A	0.15 (HAT-LAT)
60	0.5001 A	0.30 (HAT-LAT)

where A is the tidal amplitude. The allowable difference given above has been based on an amplitude of 0.5 (HAT-LAT), with a 20% increase to account for asymmetry in the tidal curve.

2.1.6 Stationarity Checks

The occurrence of constant values of data depends on the variable being measured, the sampling interval used, and the resolution of the sensor and recording equipment. The last factor has not been specifically included in the following checks, and therefore should be considered in the assessment of any data failing the tests.

a) Current Speed

Constant current speeds are uncommon although theoretically two consecutive values may be the same.

A flag should be set against each current speed data point which is equal in value to the two previous values, regardless of the sampling interval.

b) Current Direction

Almost constant current directions may be generated by topographic effects.

The following numbers of consecutive equal values are allowed depending on sampling interval:

Δt (min)	Number of consecutive equal values
5	12
10	6
15	4
20	3
30	2
60	2

A flag should be set against each current direction data point which is equal in value to the previous 12, 6, 4, 3, or 2 previous values, (as applicable).

c) Temperature

Constant temperature values are relatively common, and the number of consecutive equal values allowed is thus large, being

$$24 \times \frac{60}{\Delta t \text{ (min)}} \quad (\text{i.e. up to one day is allowed})$$

where Δt is the sampling interval in minutes. A flag should be set against all data points which are preceded by at least a day of constant values.

d) Conductivity/Salinity

Constant salinity values are also relatively common and a similar stationarity check to that for temperature data is applied. 60

i.e.
$$24 \times \frac{60}{\Delta t \text{ (min)}}$$

where Δt is the sampling interval in minutes. A flag should be set against all data points which are preceded by at least a day of constant values.

c) Pressure/Head of Water

Pressure data should respond both to the tidal rise and fall at the current meter site and the dynamic response of the mooring to the current flow. Numbers of consecutive equal values allowed are similar to those for tidal data (see appendix C2), and depend on the sampling interval:

Δt (min)	Number of consecutive equal values
5	24
10	12
15	8
20	6
30	4
60	2

This implies that stationarity up to 2 hours is allowed, but anything exceeding that is flagged.

2.1.7 Gaps

Checks for gaps in the data from each sensor should ensure that any defined periods of gaps are consistent with the number of data points nulled or absent.

2.1.8 Maxima and Minima checks

The difference between successive tidal maxima and minima in current speed should lie between the minimum neap tidal current (NTC) and the maximum spring tidal current (STC). A factor of 0.9 has been applied to the minimum NTC and a factor of 1.1 to the maximum STC range in order to allow for other effects.

Thus

$$0.9 \text{ (minimum NTC range)} \leq \begin{array}{c} |u_{\max} - u_{\min}| \\ \text{or} \\ |u_{\min} - u_{\max}| \end{array} \leq 1.1 \text{ (maximum STC range)}$$

where u_{\max} and u_{\min} are successive current speed maxima and minima. Failure of this test causes a flag to be set against the second value.

2.1.9 Times of successive maxima check

The time difference between successive current speed maxima (ΔTu_{\max}) should be between 4 ¼ and 8 ¼ hours.

$$\text{Thus } 4 \frac{1}{4} \text{ hours} \leq \Delta Tu_{\max} \leq 8 \frac{1}{4} \text{ hours.}$$

Failure of this test causes a flag to be set against the later maximum.

2.2 OCEANOGRAPHIC ASSESSMENT

2.2.1 Introduction

The lower level of oceanographic assessment involves the visual inspection of time series plots and bivariate scatter diagrams to assess the patterns or trends in the data, and to identify outliers or anomalous gaps. The general features of the data are also compared with those for the same area from any other available sources.

The higher level consists of the more detailed analysis of specific features of the data (e.g. the tidal and non-tidal signal in current velocity data using harmonic analysis) and the investigation of significant 'events' or anomalous data.

2.2.2 Current Speed and Direction

a) Lower Level

Various aspects of the current velocity data should be assessed from time series and bivariate plots, including:

i) Tidal Signal

In UK waters, the tidal currents are dominantly semi-diurnal. Thus in the time series plots of the orthogonal components of current velocity, two cycles per day should be evident. In addition, in the time series plots of current speed and direction, four speed maxima and four speed minima should be evident, while the direction should show two cycles of alternating opposing flows (i.e. approximately 180° different). It should be noted however that where tidal currents are weak, strong residual currents may mask these daily patterns in current speed and direction.

ii) Tidal Current Amplitude and Phase

Estimated spring and neap tidal current speeds and directions should be consistent with the known distribution of tidal current speeds and directions in UK waters.

The time of the maximum tidal current speed and the time of the turn of the tidal currents relative to HW at a nearby Standard Port should be consistent with the known phase differences in UK waters.

iii) Sense of Rotation of Currents

The sense of rotation of currents during a tidal cycle should be consistent with that determined from the known distribution of sense of rotation in UK waters. However, it should be noted that where tidal currents are weak, strong residual currents will tend to mask the preferred sense of rotation, while near the sea bed, or where currents are almost rectilinear, the sense of rotation may be variable.

iv) Current Profile

Where current data are available for different positions in the water column, the nature of the current profile should be assessed.

On the continental shelf, similar current characteristics should generally be evident through the water column, and maximum current speeds should generally decrease from the surface to the sea bed. In the deeper waters off the continental shelf, the current profile may show more variability, and consideration must be given to the general hydrography of the area in which the measurements were made.

v) 'Events' in the residual currents should relate to any meteorological 'event' or changes in water mass evidenced in the temperature and salinity data (if available). Persistent residuals should also be checked.

b) Higher Level

If a harmonic analysis is performed (for data sets longer than 15 days) then an oceanographic assessment of the computed values should be made, and the residual currents should be investigated.

i) Harmonic constituents

The major constituents from this analysis - M2, S2, N2, K, and O1 - should be compared with any available data to check the consistency of their amplitudes and phases, or the amplitudes and

directions of semi-major and semi-minor axes of the constituent ellipses and their sense of rotation may be compared.

Additional constituents should be compared if these are available.

In some circumstances, the differentiation between baroclinic and barotropic components may need to be investigated.

ii) Residual currents

The residual currents remaining after subtraction of the harmonically-analysed tidal current signal from the measured current data should be checked for the following:

- No tidal signal is evident in the residual currents. The presence of a tidal signal would tend to suggest that there is a timing error within the data set, or that a gap (or gaps) in the data has (have) not been identified.

It should be noted that the residual currents from scalar-averaging current meters may exhibit a tidal signal which arises from the over-reading of current speed at periods of slack water due to surface wave effects; these should be identified. Also inertial currents in UK waters are of a similar period to the semi-diurnal tidal period and may require specific attention (e.g. using rotary component analysis)

- The maximum residual current speed should be compared with the estimated 100 year storm surge current speed (giving due account to any difference in sampling interval and the difference in position in the water column between the two values). If the maximum residual current speed exceeds the estimated 100 year storm surge current speed then this should be investigated.

- Significant 'events' or anomalous data should be investigated using any other available data for comparison, and any detailed analyses which may be relevant (e.g. spectral analysis).

2.2.3 Temperature

a) Lower Level

This should include the assessment of the following:

i) Temperature range and mean temperature

Measured temperature ranges and the mean temperature should be consistent with known temperature distributions for UK waters.

ii) Trends

Observed trends (i.e. rises or falls) in the temperatures over the deployment period should conform with known changes in temperature for the time of year.

iii) Temperature profiles

Where temperature data are available for different positions in the water column, the nature of the temperature profile should be consistent with known temperature profiles.

iv) 'Events'

'Events' in the temperature data should correlate with residual current events or changes in residual currents directions, and/or events in the salinity data.

b) Higher level

This might include the assessment of:

i) Significant 'events' or anomalous data

These should be investigated using any available data from comparison, and any detailed analysis which may be relevant (e.g. spectral analysis).

ii) Short period temperature fluctuations

The temperature changes indicated by short-period fluctuations in temperature should be consistent with the vertical or horizontal temperature gradients which are considered to prevail in the region.

If internal waves are apparent, then internal wave frequencies should lie between the local inertia] frequency and the local Brunt-Vaissala stability period.

2.2.4 Conductivity/Salinity

a) Lower Level

This should include the assessment of the following:

i) Salinity range and mean salinity

Measured salinity ranges and the mean salinity should be consistent with known salinity distribution in UK waters.

ii) Trends

Observed trends in salinities over the deployment period should conform with known changes in salinity for the time of year.

iii) Salinity profiles

Where salinity data are available for different positions in the water column, the nature of the salinity profile should be consistent with known salinity profiles.

iv) 'Events'

'Events' in the salinity data should correlate with meteorological events, or changes in the residual current directions, and/or events in the temperature data.

b) Higher Level

This could include the assessment of:

i) Significant 'events' or anomalous data

These should be investigated using any available data for comparison and any detailed analyses which may be relevant.

ii) Short Period Salinity Fluctuations

Salinity changes indicated by short period fluctuations in salinity should be consistent with the vertical or horizontal Salinity gradients which are considered to prevail in the region.

iii) Water Masses and their variation

The nature of the water masses indicated by the combination of the temperature and salinity data should be consistent with known distribution of water masses. Any variation during the measurement period should be investigated.

2.2.5 Pressure/Head of Water

a) Lower Level

This should include the assessment of the following:

i) Tidal Range and Mean Level

The tidal component evident in the head of water data should be consistent with the known tidal range at the current meter site, and the mean head of water should be consistent with the documented position of the current meter in the water column.

ii) 'Events'

Any 'events' in the head of water data indicating major knockdown of the current meter mooring should correlate with periods of strong currents.

b) Higher Level

This could include the assessment of:

i) Significant 'events' or anomalous data

These should be investigated using any available data for comparison and any detailed analysis which may be relevant.

ii) Mooring Knockdown

Atmospheric pressure variations (relative to the defined mean atmospheric pressure) and the estimated (or known) tidal signal should be removed from the head of water data. The resulting data should provide an indication of the knockdown of the mooring. This should be compared with model results for the mooring under the measured current conditions, and estimates made of the vertical and horizontal motions of the current meters.

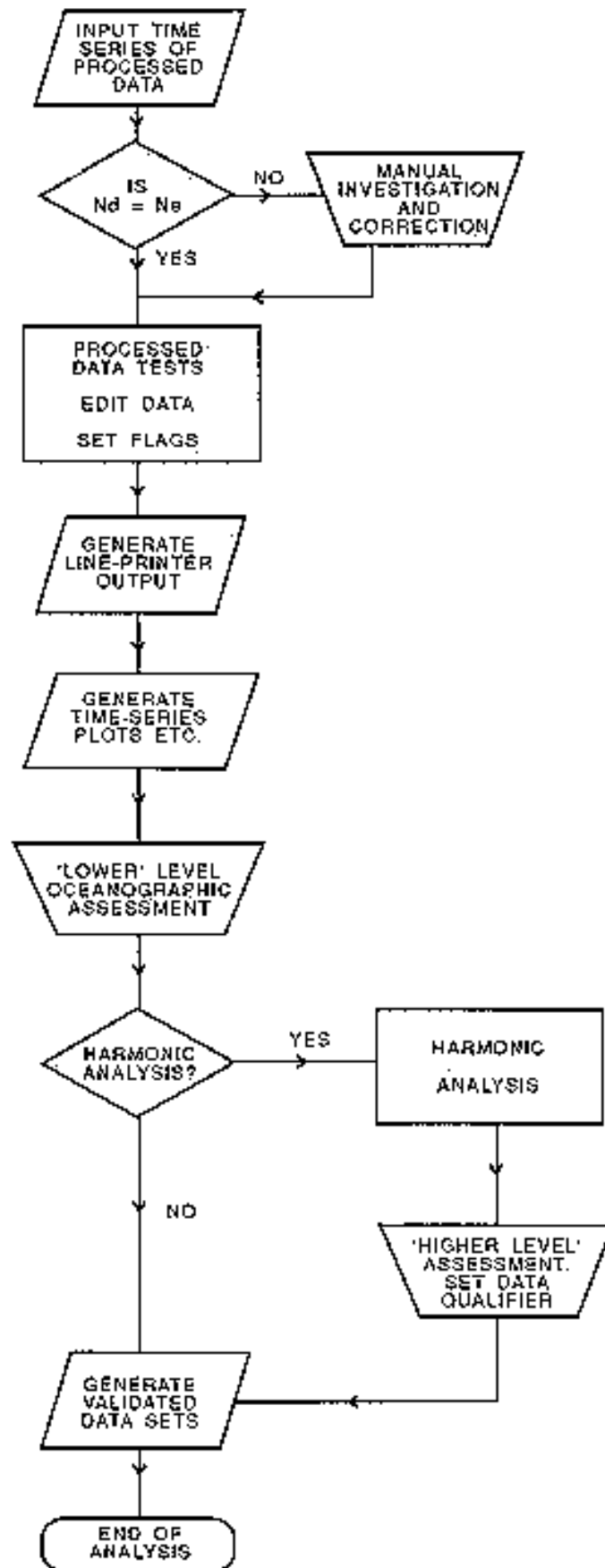

Figure B1 Flow Diagram of Quality Control Procedures for Current Meter Data

SECTION 2.2, APPENDIX B3: CURRENT METER DATA

3. DOCUMENTATION

3.1 This form should accompany any tape of current meter data which is submitted to the NODB for banking. The following notes provide some background information to the form:

3.2 DATA STANDARDS

Before data are submitted for banking it is expected that:

- a) all relevant corrections have been applied to the data
- b) all data are expressed in oceanographic terms and in SI units which should be clearly defined
- c) the data have been fully checked for quality and pre-edited for errors such as spikes and constant values
- d) sufficient series header information and documentation are collated with the data so that they can be used with confidence by scientists /engineers other than those responsible for its original collection, processing, and quality control.

Data should not be reduced in sampling frequency from the original unless:

- a) the data have already been reduced prior to quality control by the data originator, or
- b) the original sampling frequency was particularly high, for example, greater than one reading every 2 minutes.

3.3 FORMATS

Data should be submitted on 9 track digital magnetic tape in a character form (e.g. BCD, ASCII, EBCDIC, ICL tape code). The tape should be unlabelled with no control words. Details of the format should be fully specified and each individual field, together with its units, clearly defined.

3.4 DOCUMENTATION

The documentation items defined in the form, which relate directly to standard instrumentation procedures, techniques etc. in operation at the originating laboratory, need only be described and submitted to the NODB once. Subsequent data should reference the standard documentation, highlighting any modifications and including those items that relate specifically to the data.

CURRENT METER DATA

1. SERIES HEADER INFORMATION

1.	SOURCE RESPONSIBLE FOR DATA COLLECTION
2.	SOURCE RESPONSIBLE FOR PROCESSING AND QUALITY CONTROL (IF DIFFERENT FROM 1)
3.	FOR WHOM DATA COLLECTED
4.	RESTRICTIONS ON USE OF DATA
5.	COLLECTOR'S REFERENCE NUMBER FOR MOORING AND DATA SERIES
6.	LATITUDE AND LONGITUDE OF MOORING
7.	a) WATER DEPTH REDUCED TO LAT (IF NOT REDUCED, GIVE RAW VALUE) b) REFERENCE PORT (OR IF NOT REDUCED, STATE 'RAW' AND GIVE TIME OF MEASUREMENT) c) MEAN SPRING RANGE AT LOCATION (IF KNOWN)
8.	INSTRUMENT TYPE AND SERIAL NUMBER

2. DOCUMENTATION

A. GENERAL

A.1 REASON FOR DATA COLLECTION

A.2 INDICATE IF THE DATA SERIES FORMS PART OF

a) A MULTI-MOORING EXPERIMENT

b) A SERIES OF LONG DURATION

B. INSTRUMENTATION

B.1 a) TYPE OF CURRENT METER

b) MODIFICATIONS AND THEIR EFFECT ON THE DATA

B.2 INDIVIDUAL SENSORS

a) TYPE

b) ACCURACY

c) RESOLUTION

d) RESPONSE RANGE

B.3 FOR EACH SENSOR GIVE DETAILS OF CHECKS AND CALIBRATION METHODS, CHECK/ CALIBRATION DATES, AND CALIBRATION EQUATIONS OR CURVES APPLIED (DEFINE WHETHER THOSE USED WERE MEASURED OR MANUFACTURERS)

9	<ul style="list-style-type: none"> a) PARAMETER MEASURED b) ARE DIRECTION DATA IN DECREES TRUE OR MAGNETIC? c) MAGNETIC CORRECTION USED (IF ANY) d) ARE PRESSURE DATA CONVERTED TO HEAD OF WATER? e) IF CONVERTED TO HEAD OF WATER, GIVE VALUES USED FOR SEA WATER DENSITY AND ACCELERATION DUE TO GRAVITY
10.	SAMPLING PERIOD AND INTERVAL (PROCESSED DATA)
11.	HEIGHT OF METER ABOVE SEA BED OR DEPTH BELOW LAT
12.	TIME ZONE
13.	<ul style="list-style-type: none"> a) DEPLOYMENT DATE AND TIME b) RECOVERY DATE AND TIME
14.	<ul style="list-style-type: none"> a) USABLE DATA START DATE AND TIME b) USABLE DATA END DATE AND TIME
15.	<ul style="list-style-type: none"> a) NUMBER OF DATA CYCLES (FOR EACH PARAMETER) b) DATA RETURN BASED ON USABLE DATA PERIOD GIVEN ABOVE (FOR EACH PARAMETER)

B.4 INSTRUMENT PERFORMANCE (INCLUDING CONDITION ON RECOVERY; ANY NOTED MALFUNCTIONS, ANY EVENTS WHICH MIGHT HAVE AFFECTED DATA)

C. MOORING/SITE

C.1 MOORING CONFIGURATION (INCLUDING TYPE OF METERS AT SPECIFIED POSITIONS)

C.2 MOORING PERFORMANCE (INCLUDING CONDITION ON RECOVERY; WHETHER DRAGGED OR DAMAGED; ANY EVENTS, E.G. MAJOR 'KNOCK DOWNS', WHICH MIGHT HAVE AFFECTED DATA)

C.3 DESCRIBE (IF KNOWN) GENERAL NATURE OF SEA BED AND RELATION OF MOORING TO LOCAL SEA BED FEATURES OR STRUCTURES

C.4 a) METHOD OF POSITION FIXING

b) ACCURACY

C.5 METHOD OF WATER DEPTH MEASUREMENT

D. DATA SAMPLING AND PROCESSING

D1. SAMPLING SCHEME

- a) SAMPLING METHOD

- b) RAW DATA SAMPLING RATE

- c) DURATION OF INDIVIDUAL RAW DATA SAMPLE

- d) METHOD OF AVERAGING RAW DATA TO GENERATE PROCESSED DATA (IF APPLICABLE)

- e) NUMBER OF RAW DATA SAMPLES USED IN d) ABOVE (IF APPLICABLE)

- f) NOMINAL SAMPLING INTERVAL OF PROCESSED DATA

D.2 QUALITY CONTROL PROCEDURES AND FLAGS

GIVE DETAILS OF QUALITY CONTROL PROCEDURES WHICH HAVE BEEN CARRIED OUT ON THE RAW AND PROCESSED DATA FOR EACH VARIABLE. DEFINE EACH OF THE QUALITY CONTROL FLAGS WHICH ACCOMPANY THE DATA.

D.3 DATA EDITING PROCEDURES

GIVE DETAILS OF ANY DATA EDITING PROCEDURES WHICH HAVE BEEN CARRIED OUT ON THE RAW AND PROCESSED DATA.

D.4 DATA QUALITY

- a) GENERAL COMMENT
- b) REPORT ANY KNOWN ERRORS OR UNCERTAINTIES IN DATA
- c) ARE ERRORS/ UNCERTAINTIES FLAGGED?
- d) REPORT TIMING ERRORS (IF KNOWN) AND WHETHER CORRECTIONS HAVE BEEN APPLIED

D.5 OCEANOGRAPHIC ASSESSMENT

GIVE BRIEF DETAILS OF THE OCEANOGRAPHIC ASSESSMENT WHICH HAS BEEN PERFORMED ON THE DATA

D.6 ADDITIONAL COMMENTS, INCLUDING ANY ITEMS AFFECTING DATA OR HAVING A BEARING ON SUBSEQUENT USE OF DATA. (EG. COMMENTS ON BIOLOGICAL FOULING)

SECTION 2.2

APPENDIX C

WATER LEVEL DATA

B1	General Discussion
B2	Quality Control of Water Level Data
B3	Documentation

SECTION 2.2, APPENDIX C1: WATER LEVEL DATA

1. GENERAL DISCUSSION

1.1 DATA COLLECTION PROCEDURES

Water level data can be collected in a number of quite different ways: for example, they might be collected in their own right by a dedicated tide gauge; or they might be obtained as a by-product of the collection of wave data, such as by a downward-looking laser wave-measuring device. The data are usually recorded either as an analogue record on a pen and ink chart, or digitally on magnetic tape or in solid state memory. The former method is usually associated with shore-based systems such as stilling wells and bubbler gauges, whilst the latter is associated with self-contained pressure sensing units. The data recorded by pressure sensing units are either digital time series of the pressure over a predetermined sampling period, or a single measurement of pressure averaged over a pre-determined sampling period.

1.2 GENERAL QUALITY CONTROL PROCEDURES

Data which are recorded in the form of pressure need to be converted to elevation. For this the density of the water column above the gauge is required, and quality control procedures should ensure that the data required to estimate the density with sufficient accuracy are available. Additionally, some pressure gauges record absolute pressure, whilst others automatically compensate for atmospheric pressure. In the former case, atmospheric pressure data are needed, and in all cases clear documentation of the status of the data is required.

1.3 AUTOMATIC QUALITY CONTROL OF RAW DIGITAL DATA

No quality control procedures are applied directly to the raw digital data (i.e. the individual pressure or water level measurements made at a frequency of perhaps 2 Hz) except in the case of data being collected primarily to measure waves; in this case the quality control procedures which are outlined in Appendix A2 will be applied, and the flags applicable to the wave raw data may be useful in determining the validity of the water level data.

1.4 AUTOMATIC QUALITY CONTROL OF PROCESSED DATA

Automatic quality control of processed data comprises a number of tests on the output time series data which include:

- a) data limit tests,
- b) rate of change check,
- c) stationarity check,
- d) tidal range checks, and
- e) time of maxima and minima check.

Failure of one of these tests causes a flag to be set, but this does not necessarily indicate that the data point is invalid merely that further investigation is required.

1.5 OCEANOGRAPHIC ASSESSMENT

Manual oceanographic assessment takes place at two levels: a 'lower' level and a 'higher' level. At the lower level, simple checks are performed to ensure that the tidal signal is consistent with the known tidal regime. This oceanographic assessment is essentially aimed at the data set as a whole rather than at individual points. However, the analyst may determine that a particular data point or series of points is in error. Any such assessed errors should be described in the documentation which accompanies the data.

At the higher level, significant 'events' or anomalous data are investigated in detail, while additional checks are made on the data, based on the results of harmonic analysis.

Any interpolations made in the validated data set for the purpose of higher level analysis (particularly harmonic analysis) should be documented with the results of this analysis.

SECTION 2.2, APPENDIX C2: WATER LEVEL DATA

2. QUALITY CONTROL OF WATER LEVEL DATA

2.1 PROCESSED DATA QUALITY CONTROL TESTS

2.1.1 Overall Timing

- a) Check $N_d = N_e$

where N_d is the number of records in the data set

N_e is the number of records expected from the deployment time

- b) Check if sampling interval has been altered to take account of clock drift during the measurement programme.

2.1.2 Checks on input data for pressure sensors

Where pressure data are converted to head of water, the following checks should be made on the input data.

- a) The value of density used should lie between 1000 - 1030 Kg/m^3
b) The value of g used should equal 9.81 m/s^2 (or g specified in series header)
c) Atmospheric pressure corrections applied (Yes/ No/Not applicable)

2.1.3 Tests on processed time series data

Many of the tests applied automatically to time series data require prior knowledge of the HAT-LAT range. In many cases, this will be limited to an estimate based on local knowledge or obtained from co-tidal charts.

Failure of these tests does not necessarily indicate that the data are erroneous, only that they should be examined more closely. The difference between the 'Gross Error' and check limit tests is one of degree; failure of the former indicates that the data are almost certainly in error.

Individual flags are set for each data point which fails any of the tests (except the mean level test which refers to the whole data series). The tests are described in detail below:

- a) Mean level test

Where the water level has been recorded by a pressure recorder at depth, then the mean water level above the meter should correspond closely to the **known depth of the meter below the surface**. This test is carried out manually, and is used as an indicator that all is well.

- b). Gross error limits

Maximum limits are (HAT-LAT range) + (1.2 x 100yr storm surge range). For UK waters, maximum storm surge range is 5m. Thus limits are defined by

$(\text{LAT below ML} - 3.0\text{m}) \leq \text{WL} \leq (\text{HAT above ML} + 3.0\text{m})$ where WL is the water level

c) Check limits

Check limits are defined by

$$(\text{LAT below NIL}) \leq \text{WL} \leq (\text{HAT above ML})$$

d) Rate of change check

The theoretical differences between consecutive samples h_1 and h_2 for various sampling rates Δt , assuming a semi-diurnal tidal period of 12.42, hours are given below:

Δt (min)	theoretical $ h_1 - h_2 $	allowable $ h_1 - h_2 $
10	0.0843 A	0.05 (HAT-LAT)
15	0.1264 A	0.08 (HAT-LAT)
20	0.1685 A	0.10 (HAT-LAT)
30	0.2523 A	0.15 (HAT-LAT)
60	0.5001 A	0.30 (HAT-LAT)

where A is tidal amplitude. The allowable difference given above, has been based on an amplitude of $0.5(\text{HAT-LAT})$, with a 20% increase to allow for asymmetry in the tidal curve.

The flag is set against the second sample, h_2 .

c) Stationarity check

Theoretically, for a sine or cosine curve a maximum number of two consecutive samples may have the same value (assuming no aliasing). However, in practice, the number of consecutive equal values depends on the tidal range and nature of the tidal curve at a site, the resolution of the tide gauge, and the sampling interval. Suggested numbers of consecutive equal values allowed depending on the sampling interval are:

Δt (min)	Number of consecutive equal values allowed
10	12
15	8
20	6
30	4
60	2

This implies that stationarity of up to 2 hours is allowed, but any periods exceeding this are flagged.

f) Caps

Checks for gaps in the, data should ensure that any defined periods of gaps are consistent with the number of data points nulled or absent

g) Tidal range check

This is to assist in ensuring that no scale changes have occurred or that two data series have not been mismatched.

The tidal range from successive maxima (high waters) and minima (low waters) should lie between the minimum neap and the maximum spring (i.e. HAT-LAT) range.

Thus

$$\text{minimum neap range} \leq \frac{|h_{\max} - h_{\min}|}{\text{or}} \leq \text{HAT - LAT) range}$$
$$|h_{\min} - h_{\max}|$$

where h_{\max} and h_{\min} are successive water level maxima and minima. Failure of this check causes a flag to be set against the second value.

h) Time of maxima and minima

For most cases, the time difference between successive h_{\max} (high water) and h_{\min} (low water) and between successive h_{\min} and h_{\max} should be between $4 \frac{1}{4}$ and $8 \frac{1}{4}$ hours.

$$\text{Thus } 4 \frac{1}{4} \text{ hrs} \leq \frac{|Th_{\max} - Th_{\min}|}{\text{or}} \leq 8 \frac{1}{4} \text{ hours}$$
$$|Th_{\min} - Th_{\max}|$$

where Th_{\max} and Th_{\min} are the times of successive water level maxima and minima.

Failure of this check causes a flag to be set against the second value.

2.2 OCEANOGRAPHIC ASSESSMENT

2.2.1 The lower level of oceanographic assessment involves the visual inspection of time series plots to assess the patterns or trends in the data. The general features of the data are also compared with those for the same area from any other available sources.

The higher level consists of the more detailed analysis of specific features of the data (e.g. the tidal and non-tidal signal in the data using harmonic analysis) and the investigation of significant 'events' or anomalous data.

2.2.2 Lower Level.

Various aspects of the data should be assessed from time series plots including:

a) Tidal signal

In UK waters, the tides are dominantly semi-diurnal. Thus two tidal cycles per day should be evident in the time series of water levels.

b) Tidal range and tidal phase

Estimated spring and neap tidal ranges should be consistent with the known distribution of tidal ranges in UK waters. The estimated phase difference of high water and low water between the measurement site and a nearby standard port should be consistent with the known phase difference in UK waters.

c) Nature of the tidal rise and fall

The character of the tidal rise and fall should be consistent with the known tidal characteristics of the area (e.g. double high or low waters, still stands, asymmetry in the rise and fall, tidal bores).

Seiches (which are generally observed as short-period oscillations in water level) should be noted and investigated to establish if the period is consistent with the potential length and depth scales available for their generation.

In addition, any major surges which are evident in the data should be assessed in relation to meteorological 'events'.

2.2.3 Higher level

If a harmonic analysis is available (for data sets longer than 15 days) then an oceanographic assessment of the computed values should be made and the residual water levels should be investigated.

a) Harmonic constituents

The major constituents from this analysis - M_2 , S_2 , N_2 , K_1 , O_1 - should be compared with any available data to check the consistency of the amplitudes and phases, taking into account, if necessary, differences which may arise due to the seasonal modulation of amplitudes and phases.

Additional constituents should be compared if these are available.

b) Mean level

The mean level determined from the harmonic analysis should be consistent with the known depth of the sensor.

Where the mean level can be related to Ordnance Datum (OD), mean sea level relative to OD should be compared with available data from nearby sites.

c) Residual water levels

The residual water levels remaining after subtraction of the harmonically-analysed tidal signal from the measured water levels should be checked for the following:

- (i) No tidal signal is evident in the residuals. The presence of a tidal signal would tend to suggest that there is a timing error within the data set, or that a gap (or gaps) in the data has (have) not been identified.
- (ii) The residuals lie within the limits of the estimated 100 year positive and negative storm surge levels taking account of any difference in sampling interval between the measured data and surge level data and of any local phenomena which could generate lower or higher levels (e.g. river inflow, seiches).
- (iii) Significant 'events' or anomalous data should be investigated using any other available data for comparison, and any detailed analyses which may be relevant (e.g. spectral analysis). In particular, significant 'events' in the residual levels should correlate with meteorological 'events' (these meteorological events may be local or regional).

2.3 FLOW DIAGRAM

A flow diagram illustrating the quality control procedures for water level data is presented as Figure Cl.

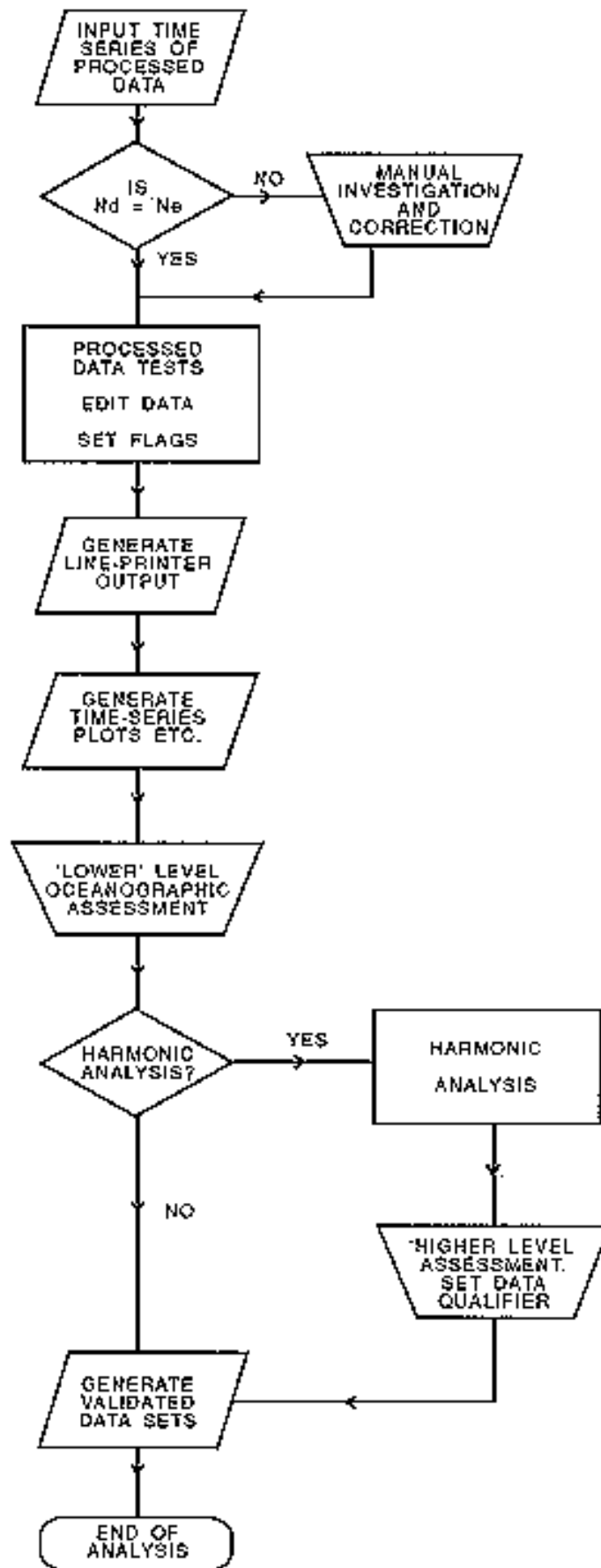

Figure C1 Flow Diagram of Quality Control Procedures for Water Level Data

SECTION 2.2, APPENDIX C3: WATER LEVEL DATA

3. DOCUMENTATION

3.1 This form should accompany any tape of water level data which is submitted to the NODB for banking. The following notes provide some background information to the form:

3.2 DATA STANDARDS

Before data are submitted for banking it is expected that:

- a) all relevant corrections have been applied to the data
- b) all data are expressed in oceanographic units and in SI units which should be clearly defined.
- c) the data have been fully checked for quality and pre-edited for errors such as spikes and constant values
- d) sufficient series header information and documentation are collated with the data so that they

can be used with confidence by scientists / engineers other than those responsible for its original collection, processing, and quality control.

3.3 FORMATS

Data should be submitted on 9 track digital magnetic tape in a character form (e.g. BCD, ASCII, EBCDIC, ICL tape code). The tape should be unlabelled with no control words. Details of the format should be fully specified and each individual field, together with its units, clearly defined.

3.4 DOCUMENTATION

The documentation items defined in the form, which relate directly to standard instrumentation procedures, techniques etc. in operation at the originating laboratory, need only be described and submitted to the NODB once. Subsequent data should reference the standard documentation, highlighting any modifications and including those items that relate specifically to the data.

WATER LEVEL DATA

1. SERIES HEADER INFORMATION

1. SOURCE RESPONSIBLE FOR DATA COLLECTION
2. SOURCE RESPONSIBLE FOR PROCESSING AND QUALITY CONTROL (IF DIFFERENT FROM 1
3. FOR WHOM DATA COLLECTED
4. RESTRICTIONS ON USE OF DATA
5. COLLECTOR'S REFERENCE NUMBER FOR RECORDER LOCATION/ MOORING AND DATA SERIES
6. LATITUDE AND LONGITUDE OF WATER LEVEL RECORDER
7. WATER DEPTH AT RECORDING SITE REDUCED TO LAT (MSL) (IF NOT REDUCED GIVE RAW VALUE AND TIME OF MEASUREMENT)
8. INSTRUMENT MODEL AND SERIAL NUMBER

9	FOR PRESSURE RECORDERS, ARE DATA CONVERTED TO ELEVATION?
10.	ARE DATA CORRECTED FOR ATMOSPHERIC PRESSURE?
11.	WATER DENSITY VALUES USED TO CONVERT TO ELEVATION
12.	ACCELERATION DUE TO GRAVITY USED TO CONVERT TO ELEVATION
13.	SAMPLING PERIOD AND INTERVAL (PROCESSED DATA)
14.	TIME ZONE
15.	a) DEPLOYMENT DATE AND TIME (WHERE APPLICABLE) b) RECOVERY DATE AND TIME (WHERE APPLICABLE)
16.	a) USABLE DATA START DATE AND TIME b) USABLE DATA END DATE AND TIME
17.	a) NUMBER OF DATA CYCLES b) DATA RETURN BASED ON USABLE DATA PERIOD GIVEN ABOVE

2. DOCUMENTATION

A. GENERAL

A.1 REASON FOR DATA COLLECTION

A.2 INDICATE IF THE DATA SERIES FORMS PART OF

- a) A MULTI-MOORING EXPERIMENT
- b) A SERIES OF LONG DURATION

B. INSTRUMENTATION

B.1 a) TYPE OF INSTRUMENT

b) MODIFICATIONS AND THEIR EFFECT ON THE DATA

c) OTHER VARIABLES MEASURED BY THE INSTRUMENT

B.2 CONVENTIONAL STILLING WELL

a) WELL DIAMETER

b) ORIFICE DIAMETER

c) ORIFICE DEPTH BELOW MEAN WATER LEVEL

d) ORIFICE HEIGHT ABOVE SEA BED

B.3 BUBBLER GAUGE

a) TUBE LENGTH

b) TUBE DIAMETER

c) ORIFICE DIAMETER

d) FORMULA USED TO COMPENSATE FOR TUBE LENGTH

B.4 PRESSURE RECORDER

a) GIVE UNITS IN WHICH THE DATA ARE PRESENTED

b) HEIGHT OF PRESSURE SENSOR ABOVE SEA-BED

B.5 OTHER RECORDING TECHNIQUE (EG. THORN-EMI WHM-1 WAVE RECORDER)

GIVE ANY RELEVANT DETAILS

B.6 SYSTEM ACCURACY

a) ESTIMATED ACCURACY OF WHOLE SYSTEM (PROCESSED DATA)

b) RESOLUTION

B.7 CALIBRATIONS

GIVE DETAILS OF CHECKS AND CALIBRATION METHODS, CHECK/CALIBRATION DATES, AND CALIBRATION EQUATIONS OR CURVES APPLIED TO THE DATA (DEFINE WHETHER THOSE USED WERE MEASURED OR MANUFACTURER'S)

B.8 INSTRUMENT MAINTENANCE

GIVE DETAILS OF FREQUENCY OF CLEANING AND SERVICING AND OF SERVICING PROCEDURES

B.9 OPERATIONAL HISTORY OF INSTRUMENTATION AND NOTED MALFUNCTIONS; ANY EVENTS WHICH MIGHT HAVE AFFECTED THE DATA.

C. SITE

C.1 COASTAL TIDE GAUGE DATA

a) BRIEF DESCRIPTION OF LOCATION OF TIDE GAUGE, INCLUDING ANY LOCAL RESTRICTIONS OR LOCAL EFFECTS SUCH AS SEICHING

b) DESCRIPTION OF TIDE GAUGE BENCHMARKS AND THEIR GRID REFERENCES

c) DATUM RELATIONSHIPS

d) DATUM HISTORY

C.2 OFFSHORE TIDE GAUGE DATA

a) BRIEF MOORING OR FIXING DETAILS

b) METHODS OF POSITION FIXING AND WATER DEPTH DETERMINATION

D. DATA SAMPLING AND PROCESSING

D1. SAMPLING SCHEME

- a) TYPE OF RECORDING - E.G. CONTINUOUS, DIGITAL, AVERAGED

- b) RAW DATA SAMPLING RATE

- c) DURATION OF INDIVIDUAL RAW DATA SAMPLE

- d) NUMBER OF RAW DATA SAMPLES AVERAGED TO GENERATE EACH PROCESSED DATA POINT (OR PERIOD OVER WHICH AVERAGING PERFORMED)

- e) REPRESENTATIVE DURATION OF EACH PROCESSED DATA POINT

- f) SAMPLING INTERVAL BETWEEN PROCESSED DATA POINTS

- g) RELATIONSHIP BETWEEN STATED TIME OF COLLECTION OF PROCESSED DATA AND THE START OF THE AVERAGING PERIOD

D.2 QUALITY CONTROL PROCEDURES AND FLAGS

GIVE DETAILS OF QUALITY CONTROL PROCEDURES WHICH HAVE BEEN CARRIED OUT ON THE RAW AND PROCESSED DATA FOR EACH VARIABLE. DEFINE EACH OF THE QUALITY CONTROL FLAGS WHICH ACCOMPANY THE DATA.

D.3 DATA EDITING PROCEDURES

GIVE DETAILS OF ANY DATA EDITING PROCEDURES WHICH HAVE BEEN CARRIED OUT ON THE RAW AND PROCESSED DATA.

D.4 DATA QUALITY

a) GENERAL COMMENT

b) KNOWN ERRORS OR UNCERTAINTIES

c) ARE ERRORS/ UNCERTAINTIES FLAGGED?

d) REPORT TIMING ERRORS (IF KNOWN) AND WHETHER CORRECTIONS HAVE BEEN APPLIED

D.5 OCEANOGRAPHIC ASSESSMENT

GIVE BRIEF DETAILS OF THE OCEANOGRAPHIC ASSESSMENT WHICH HAS BEEN PERFORMED ON THE DATA

D.6 ADDITIONAL COMMENTS, INCLUDING ANY ITEMS AFFECTING DATA OR HAVING A BEARING ON
SUBSEQUENT USE OF DATA.

SECTION 2.2

APPENDIX D

METEOROLOGICAL DATA

- B1 General Discussion
- B2 Quality Control of Meteorological Data
- B3 Documentation

SECTION 2.2, APPENDIX D1: METEOROLOGICAL DATA

1. GENERAL DISCUSSION

1.1 DATA COLLECTION PROCEDURES

Meteorological data collected from offshore platforms or buoys fall into two categories: firstly, wind speed, wind direction, gust speed, and gust direction which are recorded as an average over a predetermined period of time (usually 10 minutes for wind and 3 seconds for gust); and secondly, atmospheric pressure, relative humidity, air temperature, and sea surface temperature, which are recorded as spot values. The methods of sampling these data are discussed below:

a) Wind and gust velocity

Most wind anemometers and wind direction vanes generate an analogue dc voltage output. This output can either be sampled digitally at typical frequencies of 1Hz or 2Hz, or passed through a filter circuit which can generate running 10~minute, or 1-hourly, and 3-second means. Some systems obtain the 10-minute or 1-hourly mean by integrating the number of cup revolutions over that period. 10-minute or 1-hourly mean wind speeds and directions are referred to as mean wind speeds and directions. 3-second mean wind speeds and directions are referred to as gust speeds and directions.

Quality control on the raw data (the instantaneous wind speed and direction values) can be carried out only when the data are sampled digitally. Where digital data are not available quality control can be performed only on the resulting averaged value. In this context, the instantaneous digital data are referred to as raw data and the averaged values are referred to as processed data.

b) Other meteorological variables

As stated earlier, variables such as atmospheric pressure, relative humidity, air temperature, and sea surface temperature, are recorded as spot values, usually by interrogation of an analogue signal by a micro-processor. In order to maintain consistency in terminology, the spot samples (which in some cases may be the average of two adjacent samples collected 0.5 or 1 second apart) are referred to as processed data. Quality control is usually restricted to the processed data except in those cases where two instantaneous samples- can be compared for consistency. Where a spot reading is the average of two consecutive digital samples, then these digital samples must be considered to be raw data.

It should be noted that relative humidity data may be obtained from visual observations of wet and dry bulb thermometers, but in the meteorological instrument systems considered here they are generally values obtained from relative humidity sensors. Quality control of relative humidity data has therefore been defined in terms of relative humidity as a specific variable, rather than two separate temperatures.

1.2 AUTOMATIC QUALITY CONTROL OF RAW DIGITAL DATA

Quality control of raw digital data is limited to gross range tests, stationarity tests (flats in the data), and fluctuation tests (excessive variation between adjacent samples). Failure of any of these tests should cause a unique incrementing flag to be set, but no editing is performed on the raw data.

1.3 AUTOMATIC QUALITY CONTROL OF PROCESSED DATA

Automatic quality control of processed data is restricted to data limit checks, rate of change checks, and a check on the relationship between wind speed and gust speed. Failure of one of these tests causes a flag to be set, but this does not necessarily indicate that the data point is invalid, merely that further investigation is required.

Assessment of the data for meteorological reasonableness is the final quality control procedure, which takes place at two levels - a lower and a higher. The lower level is essentially aimed at the data set as a whole rather than at individual points. However, the analyst may determine that a particular data point or series of points is in error. Any such assessed errors should be described in the documentation which accompanies the data.

At the higher level, significant 'events' or anomalous data are investigated in detail, while additional checks are made on the data using further analytical methods.

SECTION 2.2, APPENDIX D2: METEOROLOGICAL DATA

2. QUALITY CONTROL OF METEOROLOGICAL DATA

2.1 RAW DATA QUALITY CONTROL TESTS

2.1.1 Raw Data Timing

Check $R_d = R_e$

where R_d is number of raw data values collected

R_e is number of digital raw data values expected as calculated from the sampling period and the sampling rate.

2.1.2 Gross error limits

Raw digital data are tested to ensure that they lie between predetermined maximum limits. Each occurrence of a data point outside these limits should cause a flag to be incremented, but no editing should take place. The gross limits upon which these tests are based are given below:

- a) $0 \text{ m/s} \leq \text{Wind speed} \leq 75 \text{ m/s}$
- b) $000^\circ \leq \text{Wind direction} \leq 360^\circ$

2.1.3 Spot readings

Where possible, spot readings of variables such as temperature and pressure should be checked by comparing the values of two successive digital samples. If they agree within predetermined limits then the value taken is their arithmetic mean if they do not agree, then the second and third samples are compared. If they in turn do not agree then the third sample is taken to be the measured value, and a flag is set. This sequence assists in avoiding the recording of spikes which exist in the digital record.

The predetermined limits for the spot readings may be the gross error limits defined for processed data quality control.

2.1.4 Stationarity tests

A flag should be incremented for each discrete occurrence of the following:

- a) wind speed - 20 consecutive values within 0.1 m/s
- b) wind direction - 20 consecutive values within 1°

2.1.5 Fluctuation tests

For each of the following three variables, a flag should be set at one of two levels:

- level 1 - for more than three occurrences of successive values not within the defined limits
- level 2 - for more than thirty occurrences of successive values not within the defined limits.

Wind speed - defined limits of 5m/s

Wind direction - defined limits of 20°

Gust speed - defined limits of 10 m/s or 20% of the mean value, whichever is the lesser.

2.2 PROCESSED DATA QUALITY CONTROL TESTS

2.2.1 Overall timing

For each variable, check $N_d = N_e$

where N_d is the number of records in the data set

N_e is the number of records expected from the deployment time or time interval between tape changes.

2.2.2 Checks on input data

a) Wind and gust speeds

Have mean wind and gust speed data been reduced to 10 m above sea level?

b) Wind direction

i) Are data in degrees true or magnetic?

ii) Does the magnetic correction applied lie between 0° W and 16° W.

c) Barometric pressure

Have pressure data been corrected to mean sea level?

2.2.3 Data Limit tests

Processed data are tested to ascertain whether they lie within predetermined limits which are reasonable for that area. Failure of these check tests does not necessarily indicate that the data are erroneous, only that they should be examined more closely. In addition to these 'check' tests, the data which are basically spot measurements are tested for gross errors, which imply with a degree of certainty that the data are erroneous. The results of check tests and gross error tests for these variables can be reflected in the value of one flag.

a) Gross error limits

i)	0 m/s	<	Mean wind speed	<	50 m/s
ii)	0 m/s	<	Gust speed	<	75 m/s
iii)	000°	<	Mean wind/gust direction	<	360°
iv)	-20° C	<	Air temperature	<	40° C
v)	900mB	<	Air pressure	<	1050mB
vi)	40%	<	Relative humidity	<	100%
vii)	-2° C	<	Sea surface temperature	<	25° C

b) Check limits

Check limits are imposed in order that anomalous data can be highlighted. These data may subsequently be shown to be either valid or invalid. Climatic variations over the area covered by U.K. waters rule out the specification of precise values for wind speed, air temperature, and sea temperature. There are good climatic records available for these variables, and check limits should be set after examination of the statistics. The values chosen should be at a level which is expected to be exceeded only occasionally per year for wind speed, or per month for air and sea temperature.

i) Mean wind speed

$$0 \leq \text{Wind speed} \leq \text{Site specific upper limit}$$

ii) Gust speed (maximum 3-second mean during defined sampling period)

$$\text{Wind speed} \leq \text{Gust speed} \leq \begin{matrix} (1.5 \times \text{wind speed}) \text{ or} \\ (\text{wind speed} + 5\text{m/s}) \\ \text{whichever is the greater} \end{matrix}$$

iii) Air temperature

$$\text{Site specific lower limit} \leq \text{Air temperature} \leq \text{Site specific upper limit}$$

iv) Air pressure

$$930\text{mB} \leq \text{Air pressure} \leq 1013\text{mB}$$

v) Relative humidity

$$51\% \leq \text{Relative humidity} \leq 99\%$$

vi) Sea surface temperature

$$\text{Site specific lower limit} \leq \text{Sea surface temperature} \leq \text{Site specific upper limit}$$

2.2.4 Processed data rate of change limits

Failure of a test should result in the setting of a flag; in each case the flag is set against the second measurement in the algorithm, i.e. V_2 , D_2 , T_2 , P_2 , and S_2 .

a) Mean wind speed

$$|V_1 - V_2| + |V_2 - V_3| \leq 26\text{m/s}$$

where V_1 , V_2 and V_3 are consecutive hourly wind speed measurements.

b) Mean wind direction

Maximum direction change in an hour, $\Delta\theta_{\text{max}}$, is related to the mean wind speed by

$$\Delta\theta_{\text{max}} = 85 / [\log_{10}(2V_{10})] \text{ degrees}$$

where V_{10} is the mean wind speed at 10 metres above sea level/mean sea level in metres/second.

Therefore $|D_1 - D_2| \leq 85 / [\log_{10} (2V_{10})]$ degrees

where D_1 and D_2 are consecutive hourly wind directions.

c) Air temperature

$$|T_1 - T_2| + |T_2 - T_3| < 5^\circ \text{ C}$$

where T_1 , T_2 , and T_3 are consecutive hourly temperature measurements.

d) Air pressure

$$|P_1 - P_2| \leq 2 \text{ mB}$$

where P_1 and P_2 are consecutive hourly pressure measurements.

e) Sea surface temperature

$$|S_1 - S_2| < 1^\circ \text{ C}$$

where S_1 and S_2 are consecutive hourly temperature measurements.

2.2.5 Stationarity Checks

a) Mean wind speed and direction, gust speed and direction

Mean wind and gust speeds and directions are unlikely to remain constant even for two consecutive observations, but they will occasionally for purely statistical reasons.

A flag for each variable should be set against each data point which is equal in value to the two previous values.

b) Air temperature, air pressure, relative humidity Air temperature, air pressure, and relative humidity may be constant for a short period of time.

A flag for each variable should be set against each data point which is equal in value to the three previous values (for hourly sampling).

c) Sea surface temperature

Constant sea surface temperature values are relatively common, and up to one day of consecutive values is allowed.

A flag should be set against each data point which is equal in value to the 24 previous values (for hourly sampling).

2.2.6 Gaps

Checks for gaps in the data from each sensor should ensure that any defined periods of gaps are consistent with the number of data points nulled or absent.

2.3 METEOROLOGICAL ASSESSMENT

2.3.1 Introduction

The assessment of meteorological data is essentially a manual and comparative process. At the lower level, which is considered to be the minimum, the data are checked for internal consistency, and for general agreement with the known climatology of the area.- At the higher level, the data may be compared with detailed synoptic data.

2.3.2 Lower Level

Visual inspection of presentations such as time series plots and distributions of mean wind speed by direction, plus comparison with general climatic data from adjacent sites, are essential parts of the final quality control process. Consideration should be given to:

- a) The general appearance of time series plots. These are important for highlighting errors not picked up by the automatic quality control, such as small spikes and step functions. However care must be taken to ensure real data which may appear as spikes, such as squalls, are not invalidated without further investigation.
- b) Trends in time series plots should correspond to expected trends for the time of the year - e.g. over the month of May sea surface temperature should be increasing.
- c) Meteorological 'events' should be cross-checked with other variables - e.g. the variation in mean wind speeds and directions with the variation in barometric pressure.
- d) Comparisons of the data with other meteorological data from the area. These can be very important - e.g. an unusually high frequency of winds from a particular direction during a month may be correct, or may be a result of an instrument fault.
- e) Anomalous data should be related to the regional synoptic situation e.g a high wind from an unusual direction should be correlated with synoptic charts of the barometric pressure field.

2.3.3 Higher Level

Higher level assessment may include the continuous monitoring of data in relation to the regional synoptic situation, or the further investigation of a particularly interesting or unusual event, such as the passing of an intense depression, or of anomalous data. In the latter instances, the data are compared in great detail with available synoptic charts or with time series data from a nearby measurement site. This comparison should take place over a sequence of charts, and may cover a two or three days in total. Aspects for consideration could include the strength and direction of the wind as indicated by the isobars, temperature changes at fronts, and the relationship between barometric pressure trend and the wind speed and direction.

2.4 FLOW DIAGRAM

A flow diagram illustrating the quality control procedures for meteorological data is presented as Figure D1.

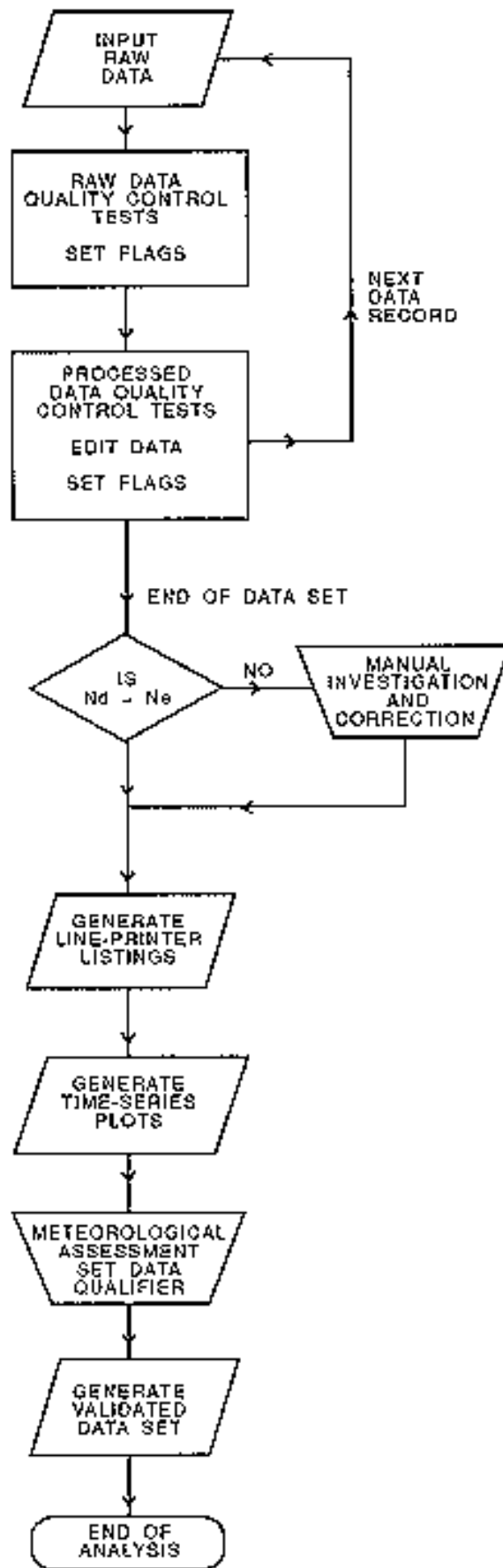

Figure D1 Flow Diagram of Quality Control Procedures for Meteorological Data

SECTION 2.2, APPENDIX D3: METEOROLOGICAL DATA

3. DOCUMENTATION

3.1 This form should accompany any tape of meteorological data which is submitted to the NODB for banking. The following notes provide some background information to the form:

3.2 DATA STANDARDS

Before data are submitted for banking it is expected that:

- a) all relevant corrections have been applied to the data
- b) all data are expressed in meteorological terms and in SI units which should be clearly defined
- c) the data have been fully checked for quality and pre-edited for errors such as spikes and constant values
- a) sufficient series header information and documentation are collated with the data so that they can be used with confidence by scientists/engineers other than those responsible for its original collection, processing, and quality control.

3.3 FORMATS

Data should be submitted on 9 track digital magnetic tape in a character form (e.g. BCD, ASCII, EBCDIC, ICL tape code). The tape should be unlabelled with no control words. Details of the format should be fully specified and each individual field, together with its units, clearly defined.

3.4 DOCUMENTATION

The documentation items defined in the form, which relate directly to standard instrumentation procedures, techniques etc. in operation at the originating laboratory, need only be described and submitted to the NODB once. Subsequent data should reference the standard documentation, highlighting any modifications and including those items that relate specifically to the data.

METEOROLOGICAL DATA

1. SERIES HEADER INFORMATION

1. SOURCE RESPONSIBLE FOR DATA COLLECTION
2. SOURCE RESPONSIBLE FOR PROCESSING AND QUALITY CONTROL (IF DIFFERENT FROM 1)
3. FOR WHOM DATA COLLECTED
4. RESTRICTIONS ON USE OF DATA
5. COLLECTOR'S REFERENCE NUMBER/NUMBERS FOR RECORDING LOCATION AND DATA SERIES
6. LATITUDE AND LONGITUDE OF RECORDING LOCATION
7. NAME AND DESCRIPTION OF OBSERVING PLATFORM (PLATFORM, RIG BUOY etc.) FROM WHICH THE DATA WERE COLLECTED
8. TIME ZONE
9. PARAMETERS MEASURED

10	WIND/ GUST VELOCITY	BAROM PRESS	AIR TEMP	REL HUMID	SEA SURFACE TEMP
a)	INSTRUMENT MODEL AND SERIAL NUMBER				
b)	HEIGHT ABOVE SEA LEVEL/MEAN SEA LEVEL				
c)	SAMPLING PERIOD				
d)	SAMPLING INTERVAL				
e)	DATA SERIES START AND END DATES AND TIMES				
f)	NUMBER OF DATA CYCLES				
g)	DATA RETURN BASED ON d), c), AND f)				
11.	a) HAVE MEAN WIND/GUST SPEEDS BEEN REDUCED TO 10 M ABOVE SEA LEVEL/MEAN SEA LEVEL? b) SPECIFY METHOD OF REDUCTION USED (WHERE APPLICABLE) c) ARE, DIRECTION DATA IN DECREES TRUE OR MAGNETIC? d) MAGNETIC CORRECTION USED (IF ANY) e) HAVE BAROMETRIC PRESSURE DATA BEEN CORRECTED TO MEAN SEA LEVEL? f) SPECIFY CORRECTION APPLIED (WHERE APPLICABLE)				

2. DOCUMENTATION

A. GENERAL

A.1 REASON FOR DATA COLLECTION

A.2 INDICATE IF THE DATA SERIES FORMS PART OF

a) A MULTI-LOCATION EXPERIMENT

b) A SERIES OF LONG DURATION

B. INSTRUMENTATION

WIND/
GUST

BAROM
PRESS
VELOCITY

AIR
TEMP

REL
HUMID

SEA
SURFACE
TEMP

B.1

a) TYPE OF INSTRUMENT

b) MODIFICATIONS

c) ACCURACY

d) RESOLUTION

B.2 UNITS IN WHICH
DATA ARE PRESENTED

B.3 CALIBRATIONS

FOR EACH SENSOR GIVE DETAILS of CHECKS AND CALIBRATION METHODS CHECK /CALIBRATION DATES, AND CALIBRATION EQUATIONS OR CURVES APPLIED TO THE DATA (DEFINE WHETHER THOSE USED WERE MEASURED OR MANUFACTURER'S)

B.4 INSTRUMENT MAINTENANCE

FOR EACH SENSOR GIVE DETAILS OF FREQUENCY OF SERVICING AND SERVICING PROCEDURES

B.5 INSTRUMENT PERFORMANCE

FOR EACH SENSOR GIVE DETAILS OF OPERATIONAL HISTORY, KNOWN MALFUNCTIONS, OR ANY EVENTS WHICH MIGHT HAVE AFFECTED THE DATA

C. SITE

C.1 BRIEF DESCRIPTION OF THE INSTRUMENT PLATFORM, ITS CONFIGURATION, AND ANY DETAILS RELEVANT IN INTERPRETING THE RESULTS

C.2 DESCRIBE THE POSITION AND EXPOSURE OF EACH SENSOR (PARTICULARLY WIND VELOCITY) GIVING DETAILS OF ANY KNOWN OR EXPECTED EFFECTS SUCH AS WIND SPEED SHELTERING OR WIND DIRECTION DEVIATIONS. PROVIDE PHOTOGRAPHS, PLANS, SKETCHES AS NECESSARY

D. DATA SAMPLING AND PROCESSING

D.1	SAMPLING SCHEME	WIND/SPEED	WIND DIRN	GUST SPEED	GUST DIRN	BAROM PRESS	AIR TEMP	REL HUMID	SEA SURF. TEMP
a)	TYPE OF RECORDING e.g. CONTINUOUS, SPOT, AVERAGED								
b)	AVERAGING PERIOD (WHERE APPLICABLE)								
c)	SAMPLING INTERVAL								
D.2	QUALITY CONTROL PROCEDURES AND FLAGS GIVE DETAILS OF QUALITY CONTROL PROCEDURES WHICH HAVE BEEN CARRIED OUT ON THE RAW AND PROCESSED DATA FOR EACH VARIABLE. DEFINE EACH OF THE QUALITY CONTROL FLAGS WHICH ACCOMPANY THE DATA.								
D.3	DATA EDITING PROCEDURES GIVE DETAILS OF ANY DATA EDITING PROCEDURES WHICH HAVE BEEN CARRIED OUT FOR EACH VARIABLE.								

D.4 DATA QUALITY

GIVE ANY INFORMATION ON DATA QUALITY INCLUDING GENERAL COMMENTS, DETAILS OF ANY KNOWN ERRORS OR UNCERTAINTIES IN DATA, AND INFORMATION AS TO WHETHER THERE ERRORS AND UNCERTAINTIES ARE FLAGGED.

D.5 METEOROLOGICAL ASSESSMENT

GIVE BRIEF DETAILS OF THE METEOROLOGICAL ASSESSMENT WHICH HAS BEEN PERFORMED ON THE DATA

D.6 ADDITIONAL COMMENTS, INCLUDING ANY ITEMS AFFECTING DATA OR HAVING A BEARING ON SUBSEQUENT USE OF DATA.

SECTION 2.3

Restricted distribution

D1BCP-VII/3
Paris, 6 December 1991
English only

INTERGOVERNMENTAL OCEANOGRAPHIC
COMMISSION (of UNESCO)

WORLD METEOROLOGICAL
ORGANIZATION



Seventh Session of the Drifting-Buoy Co-operation Panel
Toulouse, France, 15-18 October 1991

SUMMARY REPORT

CONTENTS

PLEASE NOTE ONLY PARTS OF THIS DOCUMENT HAVE BEEN REPRODUCED

Page No.
if included

Summary Report

1. Organization of the Session
 - 1.1 Opening of the session
 - 1.2 Adoption of the agenda
 - 1.3 Working arrangements
2. **Reports**
 - 2.1 Report by the Chairman of the Drifting-Buoy Co-Operation Panel
 - 2.2 Report by the Technical Co-ordinator
 - 2.3 Report by the Secretariats
 - 2.4 Reports by the Action Groups of the Panel
3. **Financial and administrative matters**
 - 3.1 Financial situation
 - 3.2 Review of contracts
 - 3.3 Future employment status of the Technical Co-ordinator and commitments for future funding
4. **Relationship with international programmes/organizations**
 - 4.1 World Climate Research Programme (WCRP)
 - 4.2 World Weather Watch (WWW)
 - 4.3 Integrated Global Ocean Services System (ICOSS)
 - 4.4 Global Ocean-Observing System (COOS) and Global Climate Observing system (GOOS)
5. **Reports On Current And Planned Drifting-Buoy Programmes**
6. **Co-ordination activities**
 - 6.1 Quality control of drifting-buoy data
 - 6.2 Code matters
 - 6.3 New Argos GTS processing chain
 - 6.4 Combined meteorological /oceanographic drifting buoys
 - 6.5 Formation of other action groups
 - 6.6 Other co-ordination activities
7. **Publications**
8. **Review of the Panel's operating procedures and of the Technical Coordinator's tasks**
9. **Election of the Chairman and the Vice-Chairman of the Panel**
10. **Date and place of the next session**
11. **Closure of the session**

ANNEXES

**Page No.
if included**

- I. Agenda
- II. Report by the Technical Coordinator
- III. List of GTS Bulletin Headers Used for GTS Distribution of Drifting-Buoy Data
- IV. Drifting-Buoy Cooperation Panel Account as at 30 September 1991
- V. GTS Chain Fund Account as at 30 September 1991
- VI. UCAR Financial Report for Year 1 June 1990 to 31 May 1991
- VII. Modification No. 2 to Support Agreement between World Meteorological Organization and University Corporation for Atmospheric Research
- VIII. Contract between World Meteorological Organization (WMO) and Service Argos Inc.
- IX. Draft UCAR Budget 1992/93
- X. Draft Table of Contributions for 1992/93
- XI. The WOCE/TOGA Surface Velocity Programme (VCP)
- XII. Proposed Operating Working Procedures for Drifting-Buoy Data Quality Control
- XIII. Project for a New Argos GTS Processing Chain
- XIV. Operating Procedures for the Drifting-Buoy Cooperation Panel
- XV. Drifting-Buoy Cooperation Panel Workplan and Objectives for the Seventh Year
- XVI. List of Participants
- XVII. List of Abbreviations and Acronyms

6. CO-ORDINATION ACTIVITIES

6.1 QUALITY CONTROL OF DRIFTING-BUOY DATA

The Technical Co-ordinator reported on quality control issues raised during the Sixth Session of the Panel and also presented new proposed operating working guidelines for drifting buoy data quality control. On the basis of this report and following discussions on the subject, the Panel agreed the actions described in the following paragraphs.

Considering the important delays involved between the time the statistics are produced and the time a needed change is actually implemented through contact with the owner of the buoy (4 to 10 days), the Chairman of the DBCP, in conjunction with the Technical Co-ordinator, decided during the intersessional period not to ask ECMWF to provide the Technical Co-ordinator with ECMWF statistics on a weekly basis. The Panel however asked the ECMWF Representative at the session whether the European Centre could: (i) take the originating LUT into consideration when producing such statistics, and (ii) provide the Technical Co-ordinator with the list at the beginning of each month as well as on the 15th of each month, using one month of data each time. The ECMWF Representative agreed to implement this proposal.

As far as using flags in GTS messages is concerned, for indicating data quality, it was pointed out that the new Argos GTS processing chain will provide for the BUFR code after 1993 and that flag information could be included in such messages. The Panel therefore agreed not to consider this issue further during the present session.

Early in 1991, following DBCP-V1 recommendations and discussions with the Technical Co-ordinator, and after having advertised it widely, the Ocean Product Center of NOAA resumed distribution of quality-controlled BATHY messages generated from original DRIBU messages of ATLAS moored buoys. The Panel expressed its appreciation to the OPC for its efforts in this regard.

Considering the importance of consistency between data being distributed from Argos Global Processing Centres and Regional Processing Centres, the Chairman of the DBCP asked CLS/Service Argos to allow global distribution on GTS of drifting buoy data from the Australian regional centre, received through the Melbourne Local User Terminal. Especially concerned are buoys belonging to the Australian Bureau of Meteorology, the New Zealand Meteorological Service and the US National Data Buoy Center (for TOGA). CLS/Service Argos informed the Panel that it was willing to do this, provided that the buoy description would be updated once a week only for buoys entering and leaving the LUT visibility. The Panel felt this was acceptable and thanked CLS/Service Argos for its kind offer.

New proposed operating working guidelines for drifting-buoy data quality control were presented by the Technical Co-ordinator and discussed in detail by the Panel. An outline of these guidelines is given in Annex XII. The main purpose of the guidelines is to speed up and rationalise the status change process for drifting buoys reporting data on GTS when action is felt necessary by meteorological centres (delayed-mode quality control). The scheme is based on a centralised electronic bulletin board shared by the various centres involved in the process. The Panel decided, in principle, to implement these guidelines as from 1 January 1992. In the meantime, Service Argos Inc., in conjunction with the Technical Co-ordinator would study relevant issues in detail so that the Chairman of the DBCP can make a decision on what bulletin board service to use (e.g. Omnet, Argos, other) and who should pay for it. Before 1 January 1992, a Sub-group of Experts including the Technical Co-ordinator, Mr. Archie Shaw (Service Argos Inc.), Mr. Ray McCrath (ECMWF), Dr. Paul Julian (NOAA), Mr. Pierre Blouch (Meteo France) and Mr. Flosi Sigurdsson (Icelandic Meteorological Office), was designated by the Panel to agree on a standardised format for exchanging information via the bulletin board. The NDBC, Meteo France, ECMWF, UKMO and ocean Product Center Representatives agreed in principle to participate in the procedures given in the guidelines, thus acting as Principal Meteorological or Oceanographic Centres responsible for drifting-buoy data quality control (PMOC). The Panel thanked these agencies for undertaking such very useful roles, which are likely to improve the overall quality of drifting-buoy data circulating on GTS.

It was decided that the working guidelines, as presented in Annex XII, could be changed by the Chairman of the DBCP, if felt necessary, and that the period between 1 January 1992 and the next DBCP session shall be considered as a trial period. Formal decision to continue with, or cease, these procedures shall be taken at the next Panel session, based on the trial results.

The question of introducing automatic real-time data quality control checks in the system and, particularly, to include these in the specifications of stage 3 for the new Argos GTS processing chain, was raised. These tests would generate alarms to the Technical Co-ordinator and/or flags in GTS messages but would definitely not remove data from GTS distribution. It was noted, however, that a decision as to whether or not to implement such checks was premature at this stage, in view of the introduction, from 1 January 1992, of the delayed-mode procedures agreed above. The Panel therefore decided to defer a decision on this issue until its next session, when it would have had a chance to assess the efficiency and relevance of these procedures.

SECTION 2.3, ANNEX XII

PROPOSED OPERATING WORKING PROCEDURES FOR DRIFTING-BUOY DATA QUALITY CONTROL

The following principles were adopted or agreed upon by the Panel at previous sessions:

- (i) Meteorological Centres are in the best position to undertake data quality control (DBCP-VI).
- (ii) Principal Investigators and Meteorological Centres share the responsibility of data quality control (DBCP-VI).
- (iii) The Technical Co-ordinator is in the best position to act as a focal point between GTS users and Principal Investigators (DBCP-V, VI).
- (iv) Argos is responsible for assuring that gross errors are automatically eliminated from reports distributed on GTS (DBCP-VI).

In order to implement these principles, the following operating procedures or actions are suggested:

1 . PGCs

Each Principal Investigator (PI) of an Argos programme reporting data on GTS to designate a person responsible for making changes on PTT or sensor information present in the Argos system. Let us call this person the Programme GTS Co-ordinator (PCC). The PCC can, of course, be the PI himself but could also be a designated programme Technical Co-ordinator, as is done for the EGOS programme. If such a person does not exist as yet, for a given Argos programme, the Technical Co-ordinator of the DBPC would contact the Principal Investigator and discuss the issue in order to find someone. In a few cases, when a PI allows his platforms being distributed on GTS but does not want to be involved in the process, the Technical Co-ordinator could act as a PGC (i.e. the Technical Co-ordinator of the DBCP can directly ask Argos to make a change).

2. PMOCs

If possible, the DBCP to request one or more agencies or institutions to volunteer as being Principal Meteorological or Oceanographic Centre responsible for controlling Argos GTS data on an operational basis (PMOC), for given physical variables, either regionally or globally. Presently, at least the following centres which are operating quality control procedures either in real time or deferred time, locally and /or globally, express the willingness to act as PMOCs:

- the Centre de Meteorologie Marine (METEO FRANCE /CNRM / CMM, Brest, France);

- the European Centre for Medium Range Weather Forecasts (ECMWF, Reading, United Kingdom);
- the National Data Buoy Center (NOAA/ND13C, Stennis Space Center, Mississippi, USA);
- the Ocean Product Center (NOAA/OPC, Camp Spring, Maryland, USA);
- the United Kingdom Meteorological office (UKMO, Bracknell, United Kingdom).

It is desirable that the following centres agree to act as PMOCs:

- the Australian Bureau of Meteorology (ABOM, Melbourne, Australia);
- the Japan Meteorological Agency (JMA, Tokyo, Japan);
- the New Zealand Meteorological Service (NZMS, Wellington, New Zealand);
- the South African Weather Bureau (SAWB, Pretoria, South Africa)* .

National focal points for drifting-buoy programmes should be requested to designate national PMOCs and possibly to act themselves as PMOCs.

3. Bulletin Board

After cost estimates which are performed by Service Argos Inc. and the Technical Co-ordinator, the Chairman of DBCP will propose a mechanism for creating a bulletin board (Omnet, Argos, others). The Panel proposed to name the bulletin board "BUOY.QC".

- 3.1 ECMWF, OPC, METEO FRANCE and UKMO monitoring statistics will be delivered on the bulletin board.
- 3.2 Any suggestion for modification (i.e. recalibrate or remove sensor from GTS or any problem noticed (e.g. bad location) on a drifting buoy reporting data on GTS should be placed on the bulletin board. Meteorological centres should be encouraged to make such suggestions.
- 3.3 Any feed back available on a recalibration actually implemented shall be placed on the bulletin board.
- 3.4 Any information deposited on a bulletin board shall remain for 30 days only.

4. Operating Procedures for Dealing with Potential Problems on GTS (Drifting-Buoy Data, see diagram)

- 4.1 PMOCs noticing potential problems on GTS should suggest an action via the bulletin board. A standardised, telegraphic format is proposed (see Appendix): one message per platform, showing the WMO number and the proposed change, directly in the "subject" line, with additional comments appearing in the text itself, using a free format if felt necessary by the PMOC (see example in Appendix). The format will soon be finalised by a sub-group of experts before these procedures are actually implemented.
- 4.2 PMOCs noticing bad location or bad sensor data episodically appearing an GTS message should copy the message on the bulletin board, indicating from which LUT the message was transmitted. Although it is recommended that LUT operators access the bulletin board as well, if not possible,

* The Government of the Republic of South Africa has been suspended by Resolutions 38 (Cg-VII) and 2/74/4 (Twentieth Session of the General Conference of UNESCO) from exercising its rights and enjoying its privileges as a Member of WMO and Member State of IOC, respectively.

the Technical Co-ordinator of the DBCP or the responsible PGC or a designated PMOC (see paragraph 4.6.2) would keep them informed by telefax.

- 4.3 A 7-day delay will be respected by the Technical Co-ordinator before he actually contacts the PGC to propose the change, so that other meteorological centres may also have the opportunity to comment on the suggestion and, in that case, the Technical Co-ordinator is given the responsibility to decide which request to consider. Other data users who access the bulletin board are encouraged to check its contents regularly.
- 4.4 Then, if the PGC accepts the modification, he will request Argos to make the change. In order to keep the GTS user community informed, Argos (CLS and SAI user offices) will announce the change by means of the bulletin board (a standardised message is proposed in the Appendix) between 24 and 48 hours before it is actually implemented and will effect the change as prescribed. It is recommended that the PGC also request appropriate LUTs to implement the same changes. However, before the new Argos GTS processing chain is operational, messages can be deposited by Argos within 48 hours around the time a change is implemented.
- 4.5 If the PGC is not willing to go ahead with a proposed change, the Technical Co-ordinator of the DBCP will deposit a standard message on the bulletin board (see Appendix) in order to inform PMOCs back.
- 4.6 Local User Terminals will be urged to adopt these proposed quality control operating procedures.
 - 4.6.1 It is desirable that LUTs not willing to participate distribute drifting-buoy data on GTS to local users only (i.e. no global GTS distribution).
 - 4.6.2 LUT operators participating and having access to the bulletin board should be encouraged to inform the bulletin board each time a change is implemented, using the same format as Argos (see paragraph 4.4). If LUTs have no access to the bulletin board, they should be encouraged to inform the Technical Co-ordinator of the DBCP of actual changes so that he can inform the bulletin board.
- 4.7 While the Technical Co-ordinator is on travel or away from his office, a PMOC will be asked to check the bulletin board on his behalf and take similar action. This responsibility could be assigned on a rotating basis.

5. List of PGCs

This list will be published by the Technical Co-ordinator on a monthly basis via the bulletin board or regular mail, so that action can still be taken while he is on travel or away from his office.

6. DBCP, WMO and IOC Secretariats

They will promote these quality control operating guidelines and encourage participation in this scheme.

SECTION 2.3, ANNEX XII, APPENDIX

Standardised Format for Information Deposited on the Bulletin Board

Notations:

- 1 - Uppercases are constant field values and will appear as shown in the subject line; e.g. ASK will appear as 'ASK' in the subject line.
- 2- Lowercases are used to designate variable data fields; If the name of the field is on 5 characters, then the field value must be coded using 5 characters (completed with spaces if necessary); e.g. it can be coded as 'AP' to indicate Air Pressure or as 'SST' to indicate Sea Surface Temperature.
- 3- The line 12345678901234567890123456789012 is just here to indicate the number of characters used (32 maxi) and their position; It has no other specific meaning.

Operating Guidelines for Drifting Buoy data Quality Control

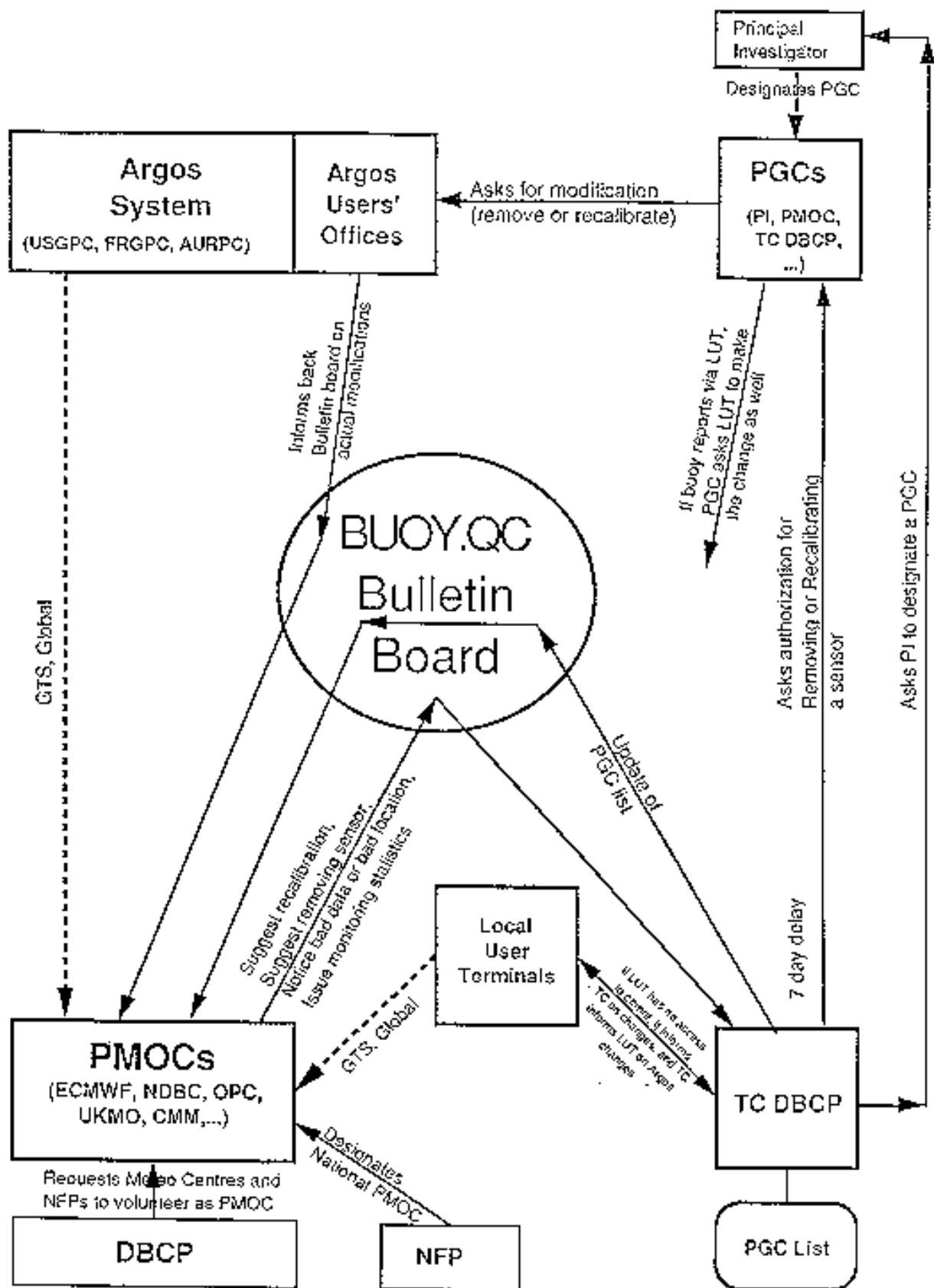

1 . Proposals for status change (by Meteo Centres, i.e. PMOCs):

When detecting bad data circulating on GTS, Meteorological Centres can propose changes on buoy status (remove or recalibrate sensor) via the bulletin board. Proposals are done using a standardised telegraphic format in the subject line. Comments can be added in the body text.

Format:

1	2	3	4	5	6	7	8	9	0	1	2	3
	4	5	6	7	8	9	0	1	2	3	4	5
	6	7	8	9	0	1	2					
h	A	S	K		t	t	t		w	m	0	#
	#		p	p	p		o	v	a		u	c

Meaning:

It is proposed to remove or recalibrate one or more sensors for one given buoy.

h: One figure, 1 to 9, to indicate the number of the request for the same buoy, for example, the first proposal would be coded 1 ASK..., and if another Meteo Centre feels necessary to comment on the same proposal, it can suggest another action and name it 2ASK, etc.

ttt: Type of proposal:
 RMV for removing sensor data from GTS
 REC for recalibrating a sensor
 CHK for checking data carefully

wmo##: WM0 number of the buoy (Albwnbnnb)

ppp: Physical variable (sensor) to consider:
 AP: Air Pressure (coded as 'AP')
 AT: Air Temperature (coded as 'AY')
 SST: Sea Surface Temperature
 WD: Wind Direction (codes as 'WD')
 WS: Wind Speed (coded as 'WS')
 APT: Air Pressure Tendency
 POS: Position of the buoy
 TZ: Subsurface temperatures (codes as 'TZ'): The depths of the probes and proposed actions should be placed in the body text, not in the subject line (not enough room)
 ALL: All buoy sensors (e.g. remove all buoy data from GTS)
 Blank:(coded as 3 space characters, i.e. ') Informations are detailed in the body text.

o: Operator to use for proposed recalibration (mandatory and used only when ttt='REC'):
 +: Add the following value to the calibration function
 -: Subtract the following value from the calibration function
 *: Multiply the calibration function by the following value (e.g. rate for recalibrating wind speed sensor)

value: Value to use for proposed recalibration (mandatory and used only when ttt='REC'); the value is coded on 5 characters and completed with space characters if necessary. It is provided using the following physical units:

Air Pressure:	Hecto Pascal
Temperatures:	Celsius degrees
Wind speed:	m/s
Wind Direction:	Degrees
Air Pressure Tendency:	Hecto Pascal
Positions:	Degree + Hundredth
Rate:	No unit

Examples:

No.	Delivered	From	Subject	Lines
1	Oct 15 10:53	NDBC.CENTER	1 ASK REC 17804 AP +2.2	0
2	Oct 15 13:15	NDBC.CENTER	1 ASK RMV 62501 ALL	5
3	Oct 16 8:02	J.ANDRE	2ASK REC 17804 AP +2.4	4
4	Oct 17 7:34	TOGA.ECMWF	1 ASK CHK 44532 POS	5
5	Oct 17 10:18	J.ANDRE	1 ASK REC 44704 US *1.5	0

Message1: NDBC proposes to recalibrate Air Pressure sensor of buoy 17804 by adding 2.2 hPa.

Message2: NDBC proposes to remove buoy 62501 from GTS distribution. Explanations are given in the body text (5 lines).

Message3: Meteo France comments (2ASK) on NDBC proposal for recalibrating air pressure sensor of buoy 17804. Meteo France suggests to add +2.4 hPa instead of +2.2 hPa. Argumentation is provided in the body text (4 lines).

Message4: ECMWF suggests to check positions of buoy 44532. Details are given in the body text (5 lines).

Message5: Meteo France proposes to recalibrate Wind speed sensor of buoy 44704, by multiplying data by 1.5.

2. Argos or LUT answer for changes actually implemented

When a change is implemented on GTS platforms, a message shall be deposited the bulletin board, by Argos or the LUT considered, no later than 24 hours after the change was implemented. All the information will be encoded into the subject line, the body text being empty. the format of the subject line is as follow:

Format:

```

1      2      3      4      5      6      7      8      9      0      1      2      3
      4      5      6      7      8      9      0      1      2      3      4      5
      6      7      8      9      0      1      2
c      c      c      c      t      t      t      w      m      o      #
      #      h      p      p      p      o      v      a      l      u      e
      h      h      :      m      m

```

Meaning:

Argos (i.e. the French Global Processing Center of Toulouse (FRGPC) or the US Global Processing Center of Landover (USCP0) or Local User Terminals (LUT) inform the bulletin board each time a change is actually implemented on a buoy status.

- cccc: Originating Center:
 - LFPW = FRCPC, Toulouse
 - KARS = USCP0, Landover
 - ENMI = Oslo LUT
 - BGSF = Sondre Stromfjord LUT
 - CWEG = Edmonton LUT

ttt, wmo###, ppp, ovalue: Same as for paragraph 1

hh:mm: UTC time the change is implemented in hours and minutes. The date is the date the message is deposited on the bulletin board and is therefore given by the mail system itself.

Example:

No.	Delivered	From	Subject		Lines
6	Oct 15 18:15	A.SHAW	KARS	REC 17804 AP +2.3 12:16	0

Message6: Buoy 17804 Air Pressure sensor was recalibrated by adding +2.3 hPa. The change was done at 12h16 UTC on 15 October. As you may notice, two proposal had been made for this buoy: NDBC proposed +2.2 hPa and Meteo France proposed 2.4 hPa. The Technical Co-ordinator of the DBCP contacted both agencies and it was then decided to apply a 2.3 hPa correction.

3. PGC Answer if the proposal was denied

Format:

1	2	3	4	5	6	7	8	9	0	1	2	3
	4	5	6	7	8	9	0	1	2	3	4	5
	6	7	8	9		1	2					
D	E	N	1		t	t	t		W	m	0	#
	#		p	p	p		0	v	a	1	U	e

Meaning:

The proposal was denied by the Principal GTS Co-ordinator (PGC) of the drifting buoy programme. No action was taken. Complementary information can be included in the body text.

ttt, wmo###, ppp, ovalue: same meaning as in paragraph 1. ovalue is mandatory and used only when ttt='REC'.

Example:

No.	Delivered	From	Subject		Lines
7	Oct 15 19:12	J.ANDRE	DENI	RW 62501 ALL	0

Message7: In the body text: Data were sent on GTS before deployment by mistake. The buoy is now deployed and data look good. There is therefore no need for removing data from GTS distribution.

SECTION 2.4

INTERGOVERNMENTAL OCEANOGRAPHIC COMMISSION

Manual of Quality Control Algorithms and
Procedures for Oceanographic Data Going into
International Oceanographic Data Exchange

(submitted by the Chairman of the Task Team on
Oceanographic Data Quality Control)

TABLE OF CONTENTS

	Page
FOREWORD	223
INTRODUCTION	225
1. ERROR SOURCES IN OCEANOGRAPHIC DATA	226
2. ALGORITHMS FOR DATA QUALITY CONTROL	228
2.1 Control of Accompanying Documents & Recording Formats	228
2.1.1 Magnetic Tape Testing	228
2.1.2 Control Printing	228
2.2 Checking whether the Data Set meet the Requirements of the Observation Programme as to its Completeness & Contents	230
2.3 Control of Physical Parameter Values & Descriptive Characteristics	230
2.3.1 Checking the Appropriate Ordering of Data	230
2.3.2 Checking the Completeness of Observations	230
2.3.3 Checking the Data Validity	230
2.3.4 Checking the Data for Obeying Physical Laws	230
2.3.5 Checking Statistical Tests	231
2.3.6 Checking the Regularities of Space & Time Variations of Data	231
2.3.7 Algorithm Description Form	231
3. OCEANOGRAPHIC DATA PREPARATION FOR INTERNATIONAL EXCHANGE	232
3.1 Checks & Calibration Instruments	232
3.1.1 Data Collection Programmes of Short Duration (less than 6 months)	232
3.1.2 Data Collection Programmes of Long Duration (beyond 6 months)	233
3.2 Recommendations as to the Data Set Layout	233
ANNEXES	
Annex 1	237
Annex 2	238
Annex 3	239
Annex 4	245
Annex 5	246
Annex 6	247
Annex 7	249
Annex 8	250
Annex 9	251
Annex 10	252
Annex 11	253
Annex 12	253

FOREWORD

The oceanographic community concerned with the reliability and compatibility of oceanographic observation materials adopted Resolution IODE - XII.9 (XII session of the IOC Technical Committee on International Oceanographic Data Exchange, Moscow USSR, 10-17 December 1986) whereby a Task Team on Oceanographic Data Quality Control was established whose terms of reference consisted among other things in preparing a Manual of Data Quality Control Algorithms and Procedures during the Intersessional period.

This draft is the first version of the Manual. It is forwarded to the TT members for review and comments which should be forwarded to the address:

6, Korolev Str.
Obninsk, Kaluga Region
249020 USSR
oceanographic Data Centre

V.I. Lamanov
Task Team on oceanographic Data
Quality Control, Chairman

INTRODUCTION

Field oceanographic observation data are the information base for studying physical-chemical, biological and geological-geophysical processes which are currently taking place in the ocean or took place in the past. Due to the heat-moisture-gas- and energy exchange between the ocean and the atmosphere continuously taking place on 70% Earth surface, the World Ocean is the major component of the planetary system "Ocean-atmosphere" whose state determines to a great extent environmental conditions in which man lives.

The increasing complexity is the main peculiarity of scientific and applied problems of the World Ocean study; it is also true of the management of its resources as well as the problems of studying the mechanism and various manifestations of the "atmosphere-ocean-land" interaction. Climate variability study, environmental monitoring, the economic activity of man at sea and other problems require huge volumes of various observation materials covering the ocean surface, its water column and the ocean surface atmosphere.

Over sixty countries make larger or smaller amounts of observations and analyse various parameters of the ocean and ocean surface atmosphere state from ocean-, land-, and space-based observation platforms. Due to the differences in the methods and specifications of the instruments, the measurement results or oceanographic data in different countries may differ as to their accuracy, time and space scales of measurements. Due to varying reliability of instrumentation and different primary data handling procedures the quality of data sets can also vary greatly.

It is obvious that using national data for solving the afore-mentioned problems as a mere sum can result in erroneous diagnostics inferences and consequently, erroneous forecasting. Hence, a need for international calibration of instruments and standardisation of algorithms and practices of data quality control.

There has been a case of joining efforts of a number of countries for instrument intercalibration and data validation in the practice of international scientific and technical co-operation in studying the atmosphere-ocean interaction. The positive result of this work in such international projects as GATE, IGOSS and FGGE, in particular is promising and makes us believe that continuing and expanding such efforts will yield new results of importance to the oceanographic community.

Data compatibility and reliability are essential to water temperature measuring with mercury and electric thermometers; to salinity measurements using hydrochemical technique and by measuring the electric conductivity of water; current measurements using current meters and on the basis of the electric field voltage in current conducting liquid; water temperature measurements with non-contact methods with different inclination of the scanning beam and different scanning time. Data quality control algorithms must be evaluated and standardised not only by the measured parameter type but also according to the measurement technique.

The completeness of national data sets which are incorporated in the international data holdings through the international exchange mechanism is also of importance. If quality control does not only imply the validity characteristic of the measurement co-ordinates the measured parameter value proper, etc., but also their fitness for solving the problems of an international (national) project, the space scale of observations, their complexity and duration may acquire ever increasing, even principal value. Note that the completeness and diversity of quality control procedures depend on the problem to be solved.

In this Manual an attempt is made to consider the algorithms and procedures of "basic" or general control which are unbiased to a maximum degree possible and based on well known physical laws and unambiguous logical categories. The Manual consists of three chapters and a few appendices. Chapter 1 contains a description of the main sources of erroneous and suspect values in bathometer observation sets. Chapter 11 contains algorithms and programmes meant for oceanographic data quality control. The structure of organisation-technological complex for oceanographic data quality control is presented in Chapter 111. The main requirements for the oceanographic data exchanged through the IODE are also given in the Manual.

To simplify the editing of checking algorithms, adding new control methods and simplifying their replacement, a formalised description of algorithms and procedures is given in the appendices. The algorithms given in the Appendices are used in the USSR (Russia) for classical oceanographic station checking while the procedures are used for control of geological-geophysical GF3-formatted data submitted through the IODE. For preparing the Manual the authors used the materials by the TC/IODE Chairman Dr. N. Flemming, containing requirements to oceanographic data beginning with instrumentation checks, their calibration and finishing with documentation and data quality control, data control algorithms for wave data current data, sea level and wind data; the materials submitted by the WG members from the GDR Drs. H. Lass, C. Wulf and R. Schwabe on quality control of sounding complex data. The paper was prepared by the VNIIGMI-WDC Oceanographic Centre head V.I.Lamanov (scientific supervisor) with the participation of Ye.D. Vyazilov, G.I. Prolisko, N.V. Puzova, A.A. Lykov and N.N. Mikhailov.

1. ERROR SOURCES IN OCEANOGRAPHIC DATA

Errors in oceanographic data diminishing their quality are due to various reasons. The character of the errors is essentially affected by the process of data conversion because of recurrent changes in the data presentation language. The sequence of changing languages of data presentation in the general case in the data processing system is as follows:

$$L_h \rightarrow L_{mr} \rightarrow L_{ap} \rightarrow L_c \rightarrow L_p$$

where L_h is the natural human language; L_{mr} is the language of main relationships (formulae, mathematical relations, equations); L_{ap} is the language of presentation of algorithms and programmes; L_c is the language of coded data presentation in the system; L_p is the language of presenting results to the user.

Each of the languages is associated with a certain stage of data processing. There can be three sources from which erroneous values get into the data sets:

- errors in the original data;
- errors resulting from data processing;
- computer failures.

The probability of errors at different stages of data processing obtained on the examples of operation of the USSR (Russian) Computation Centres is shown in Table 1.1. It follows from the Table that the probability of errors resulting from computer failures is a few orders of magnitude lower than those appearing in the course of data transfer from tables to computer-compatible media. It can thus be concluded that technical failures will not affect significantly the number and distribution of errors.

Errors in the original data result from imperfect measuring instrumentation, recording and transmission facilities. Parameter values outside the physically valid limits can result as well as coding errors of descriptive characteristic values, two similar levels with different parameter values, etc. There are a few reasons for duplication of levels. e.g., oceanological measurements at the same level can be made by different instruments. Second, if the parameter value seems suspect, the measurement is repeated and the first value is not deleted from the table. In this case assigning a quality flag requires some additional information on the distribution of the parameter in the given geographical area.

Table 1.1 Probability of errors in the course of data set construction

Operation	Error source	Probability of error
1. Data selection and filling tables	Data processing	$3 \cdot 10^{-4} - 10^{-5}$
2. Data transfer from tables onto computer-compatible media	Data processing	$10^{-2} - 5 \cdot 10^{-3}$
3. Data set input in the computer	Data processing	$5 \cdot 10^{-5} - 10^{-6}$
4. Data storage on computer-compatible media	Computer	$10^{-7} - 10^{-9}$
5. Data processing in the central processor	Computer	$10^{-8} - 10^{-10}$
6. Computer output on the printer	Computer	$10^{-6} - 10^{-7}$

Errors resulting from processing or rather from its stages when the parameter values or search attributes are manually written in the tables or transferred from the tables onto computer-compatible media are most numerous as well as accounting errors when data already submitted to the centre are entered into the basic set a second time.

Errors resulting from misplacing values into format cells are also added to errors in the original data in the course of data and descriptive characteristic transfer from paper to magnetic carriers. As a result there occur oceanographic stations which do not belong to the cruise, "broken" stations, differing numbers and types of observation on magnetic and paper carriers, erroneous quadrant values, confused level sequences, new erroneous parameter values, etc. These errors, unlike errors in formulae and those resulting from computer processing are not consistent, hence, more difficult to detect and correct.

Errors in the quadrant values originate from the initial data.

Erroneous quadrant value is commonly present in all the stations of the cruise. In this case some of the stations fall within land areas, others are shifted from the ocean areas to internal seas and other oceans. Detecting stations which appeared to be on land does not present any difficulty, while detecting those shifted to other ocean areas requires some additional information. It is not infrequent that such information is either not available or the parameter variability ranges in the actual and erroneous areas do not differ significantly. When observation time is recorded accurate to one hour, two stations with various co-ordinates may have the same observation date and hour. In this case "broken" stations appear after sorting by the level values and two bathythermograph stations yield several stations with one to two levels each.

Automating the recording of measured parameters from sensors directly on computer-compatible media decreases the number of errors dramatically but does not eliminate them altogether because part of descriptive data is entered manually, and sensors and other devices are prone to occasional errors or drift. Considering the character of most common errors it is useful to have two categories of oceanographic data quality control procedures and algorithms for data going to international exchange, i.e. formatting check and checks of ocean state parameters and descriptive characteristics.

The degree of detail and naming convention are different in different countries. Adopting a unified naming convention and designing agreed hierarchic schemes for quality control procedures are problems whose solution could contribute to data quality improvement.

2. ALGORITHMS FOR DATA QUALITY CONTROL

Data quality control consists in performing a number of tests allowing one to make sure the data can be used for solving various scientific and applied tasks. Three blocks of quality control for data on magnetic tape can be specified (Fig. 2.1). Note that the first two blocks of the set are basically a set of procedures and requirements to be observed so that no additional explanations and sending some additional information would be made unnecessary. The third block is commonly based on certain algorithms.

2.1 CONTROL OF ACCOMPANYING DOCUMENTS AND RECORDING FORMATS

Checks start with the visual examination of the magnetic tape reel and making sure that the tape labels are in place. The tape name, its owner, the recording density and the abridged name of the set should be given on the label.

If data exchange of the same data type is carried out on a regular basis, it is unnecessary to send detailed documentation every time, suffice it to send the certificate of the data carrier, which carries the following information: the tape name, the data sender and receiver, those responsible for the tape sending and receiving, the storage format name the archive and project names, number of cruises, squares and stations, dates of mailing and receiving. Two copies of the certificate are to be forwarded. After checking the tape one copy of the certificate is sent back to the sender with the results of the check.

A data documentation form which should accompany all data submissions to NODC is given in the Guide for Establishing a National oceanographic Data Centre. The form contains four sections:

- A. Originator Identification, containing such information as the name and address of institution, the name of expedition, platform, country, observation period, the geographical area;
- B. Scientific content of the data set (list of observed parameters, reporting units, methods of observation and instruments used, data processing);
- C. Data Format (record types used, recording model density, recording code used, file numbers and names, block and record lengths and record structure description (parameter name, position in the record, parameter length in bytes, a sample value);
- D. Instrument Calibration. Identification of the instruments used (instrument type, date of last calibration, when the calibration was performed).

For a better control of oceanographic data submissions the documentation should contain the above mentioned sections.

2.1.1 MAGNETIC TAPE TESTING

Testing the magnetic tape consists in checking the tape physical state, A procedure is used which enables obtaining information of the tape name, data file numbers and names and the numbers of blocks and records, number and types of failures file compilation dates.

2.1.2 CONTROL PRINTING

Obtaining control printing. Testing files on magnetic tape does not give an idea of the data set, before mailing the tape it is therefore necessary to have control printing of the beginning, middle and end of the tape. For this purpose use is made of programmes which allows printing according to the block number using the information obtained as a result of tape testing.

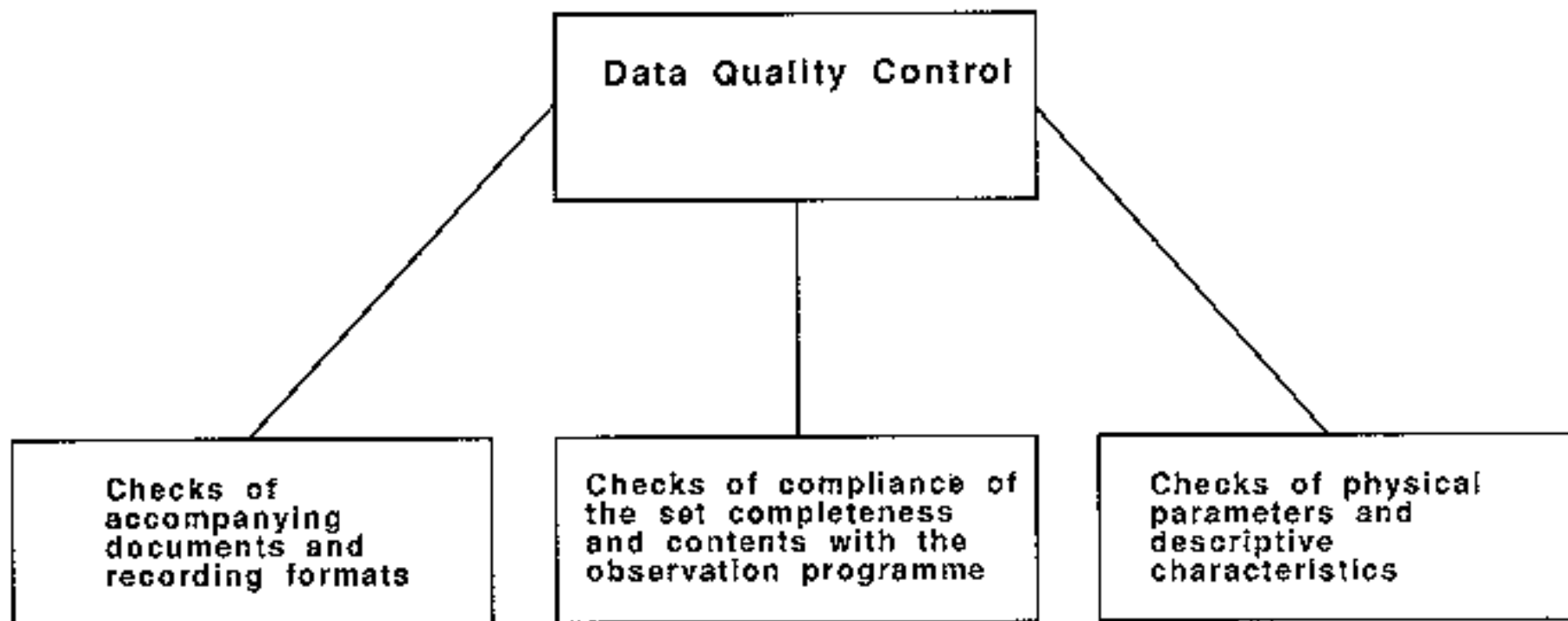

Figure 2.1 Data quality control procedures: Structure and sequence

2.2 CHECKING WHETHER THE DATA SET MEET THE REQUIREMENTS OF THE OBSERVATION PROGRAMME AS TO ITS COMPLETENESS AND CONTENTS

After the tape has been tested and the accompanying documentation has been studied it is necessary to make sure whether the data completeness and contents of magnetic tape correspond to the documentation submitted. With this in view programmes are developed for obtaining information on the data on magnetic tape according to the data set type (by cruise, by square or as time series).

In the case of cruise data sets a possibility of obtaining listings with data originator identification must be provided. Such information as the archival number, number of stations and levels, the presence of meteorological, pollution and hydrological data must also be incorporated.

The listing of the tape with data presented by squares commonly contains information on the observation amount by 5° Marsden squares and by months for long term and for the long-term period as a whole.

In the case of oceanographic data time series it is more important to have information on the time scale of observations (amount of observations per day, ten days, month and year for each time series).

2.3 CONTROL OF PHYSICAL PARAMETER VALUES AND DESCRIPTIVE CHARACTERISTICS

According to their functions, error detection methods can be classified as initial and specialised.

Initial checks must be extremely thorough and unbiased. Their task is revealing gross errors. A certain sequence is important here, i.e. the original sat is run through an array of filters beginning with simple and finishing with a most complicated ones.

Specialised tests are associated with solving a specific task. They can be more rigid and subjective. In this kind of checks it is advantageous to use parallel objective filters because minor error can only be detected by a combination of a few methods of control. Such an approach can save specialists' time and make control more effective and reliable. Besides, for decision making it is useful for the specialist to simultaneously see the response to several methods of control. Quality control as a whole consists of several checks.

2.3.1 Checking the appropriate ordering of data

A sample algorithm of the data order checking is given in Annex 3. With the help of this algorithm a station where stations are not given in the increasing order of levels is re-ordered.

2.3.2 Checking the completeness of observations

A separate-class of algorithms can be specified screening stations according to certain conditions. e.g. a station having less than three levels or no 0m level is not recorded on magnetic tape (Annex 2). In the course of statistical analysis observations with missing temperature and salinity can also be rejected.

Stations with discontinuities in temperature and salinity observations for which interpolation is possible are sampled with the help of algorithms POLN1, POLN2 (Annex 3).

2.3.3 Checking the data validity

This implies comparing the parameter values with their limits in the World Ocean. They may be global limits, local limits for each geographical area for each season, etc. (Annex 4, Tables 4.1, 4.2), whose choice depends on the tasks of the investigator.

2.3.4 Checking the data for obeying physical laws

In Annex 5 algorithms SIGMA are given revealing errors in the vertical distribution of density versus depth. SIGMA tolerates a density inversion between levels of 0.1 arbitrary units. It is to be noted,

however, that in some areas of the World Ocean the density inversion of over 0.1 sometimes occurs and the criterion is regionalised (also see Annex 6).

2.3.5 Checking statistical tests

Applying statistical tests sets the range of probable data values. Such tests used are 3σ Movene test, comparing the mean of the variance skewness and kurtosis computed for the control period and obtained for a long-term series (Annex 7). The 3σ -type test is useful in this case since 99% observations fall within 6σ range. Actual distribution, however, usually has the form which is far from normal. Besides, events having anomalous hydrophysical characteristics, i.e. statistically rare events can be extremely important when check criteria tests are set.

2.3.6 Checking the regularities of space and time variations of data

For checking daily and annual water temperature series for certain levels, regularities of daily and annual variabilities, respectively, can be applied. For checking the vertical distribution comparison with TS-curve typical of the given area is made. Control is also possible with the help of $S\sigma_1$ curve, $O_2\sigma t$ curve, and TO_2 curve. An example of the algorithm GRAD is given for revealing disturbances in the vertical distribution of temperature and salinity with depth at one oceanographic station (see Annex 8). This method can be employed for checking cruise data sets. The mathematical methods of control can be as follows: polynomial approximation, piecewise polynomial or optimal interpolation, cubic splines, differential equations, pair and multiple correlation methods, regression equations, Fourier and spectral analysis; statistical inhomogeneity tests, mathematical logic methods and the pattern recognition theory (Annexes 9, 10, 11, 12).

2.3.7 Algorithm description form

The control algorithms are described in Annexes, according to the following scheme:

1. algorithm name
2. algorithm author's code
3. purpose of the algorithm
4. algorithm descriptions input and output data
5. country name, originating organisation
6. name of document in which the algorithm has been published.

Such a description will make it possible to replace any outdated control method in the Manual and design a retrieval system. The author's code, input and output data are optional. For each algorithm recommendations as to its application can be given, e.g., the algorithm estimating the oceanographic station co-ordinates difference can be used for cruise data sets.

Certain control algorithms can be recommended for various types of data sets. e.g. in the case of cruise data sets it is useful to resort to general-purpose algorithms: estimating the allowed station co-ordinates difference, the ordering of the levels, checks for general limits, checks for observing the physical laws, When the data are recorded by squares, specialised methods of control can be used: statistical checks, checks for local limits. When the data have the form of time series, general purpose mathematical algorithms can be used, for example, spectral analysis.

3. OCEANOGRAPHIC DATA PREPARATION FOR INTERNATIONAL EXCHANGE

3.1 CHECKS AND CALIBRATION OF INSTRUMENTS

A rational approach to the checks and calibration of instruments is required from both the data gatherer and the client, in which the intention and scope of data collection programmes are fully recognised. Moreover, the approach should be developed and applied consistently and systematically, in order that confidence is maintained in the data, and that comparisons between different data sets are not distorted by unknown variations in sensor performance. It can not be over-stressed that the data are only as good as the sensors and processing equipment which have been used to measure them and without an adequate knowledge of sensor performance, the integrity of the data can only suffer as a consequence.

A distinction between checks and calibrations of instruments is recognised, and these are defined as:

- a) Checks comprise tests on the sensor output and processing equipment to ensure that they are functioning correctly and that they are performing within the manufacturer's specification.
- b) Calibrations comprise tests which provide sufficient information to allow the production of calibration curves or equations for the instrument or sensor, and these curves or equations are applied to the data obtained during the measurement period.

If problems are encountered with checks or calibrations, the following procedures are recommended:

- If a sensor is found to be performing outside the manufacturer's specifications during the predeployment check or calibration it should not be deployed until the instrument has been referred back to the manufacturer, because of uncertainty in the stability of the instrument.

- If a sensor is found to be performing outside the manufacturer's specification during the postdeployment check or calibration then the resulting action depends on the sensor involved. For those sensors which are relatively simple to calibrate, a second calibration should be performed, if not already undertaken. The results from the two calibrations should then be interpolated linearly between the times of deployment and recovery, unless step change is apparent in the data, indicating that the respective calibration may be applicable systematically up to and back to the step change.

For those sensors which cannot be readily calibrated, the data should be carefully scrutinised for any indication of changes in sensor stability or the performance of the processing equipment. If no unequivocal change in the data is evident, or no cause of the problem is readily identifiable, then the data must be considered to be compromised, unless a calibration is undertaken.

- If a sensor is lost during a data collection programme, so that no post-deployment check or calibration is possible, then any data obtained should be cautioned to this effect and particular attention paid during the data validation to any indications of sensor drift or instability.

- If a sensor has a known characteristic behaviour under certain environmental conditions, which results in a systematic error in the data, then the nature of the expected bias and details of any corrections applied to the data should be documented.

All checks and calibrations undertaken on instruments should be adequately documented, and any calibration curves or equations applied to the data should be defined.

Data collection programmes mainly fall into two different categories which are defined by the proposed duration of the measurements.

3.1.1 Data collection programmes of short duration (less than about six months)

Checks on the threshold of measurement (for mechanical sensors), or the zero offset (for acoustic and electro-magnetic sensors) should be undertaken both before deployment and after recovery of the sensor. Checks on the wind and current speed sensors performance over the expected range of speed

should be undertaken before deployment, unless the sensor has been checked during the previous six months and has not been deployed subsequently. These checks should ensure that the sensor is performing within the manufacturer's specification.

A full check should be carried out after recovery if it was not performed before deployment, or if there is any evidence of sensor instability or drift during the period of deployment.

Heave, pitch, roll sensors, together with the processing equipment used with them, should be checked both before and after deployment. The checks should include tests on the amplitude and phase response-of the heave sensor with frequency, the zero offset and the pitch-roll angles.

Other sensors include sensors for: direction, sea temperature, conductivity, underwater pressure, for either wave or tide, atmospheric pressure, air temperature, relative humidity and water level.

Calibrations should be performed on these sensors before deployment, unless the sensor has been calibrated during the previous six months and has not been deployed subsequently.

Checks should be performed upon recovery; although a calibration should be undertaken if it was not done before deployment or there is evidence of sensor instability or drift during its deployment.

3.1.2 Data collection programmes of long duration (beyond six months)

Programmes of long duration often continue five or more years. The checks and calibrations undertaken on sensors and processing equipment should be similar to that for programmes of short duration, but with certain additions.

Full checks and calibrations should always be undertaken at the start and end of the programme, and also at regular intervals during the programme.

3.2 RECOMMENDATIONS AS TO THE DATA SET LAY-OUT

Along with the oceanographic variables data sets must contain descriptive characteristics, on which data retrieval can be based in future. The characteristics should contain information on when, where and by whom the measurements were made, what instruments were used and what their accuracy is.

An oceanographic data set prepared for international exchange must be documented in such a way that general information on the set is made available and its quality is estimated.

A code table is recommended for describing the quality of a data set on magnetic tape:

- 0 - all data are correct;
- 1 - a small portion of data (0-10%) is suspect but can be used;
- 2 - an essential portion of data (00-50%) is suspect but can be used;
- 3 - over half the data (50-80%) are suspect but can be used;
- 4 - almost all data are suspect (80-100%) but can be used;
- 5 - a small portion of data (0-10%) is suspect and cannot be used;
- 6 - an essential portion of data (10 to 50%) is suspect and cannot be used;
- 7 - over half the data (50 to 80%) are suspect;
- 8 - reserve;
- 9 - no information on the data quality.

For deep-sea bathometer and marine hydrometeorological observations specific code tables are suggested:

Deep-sea bathometer data:

- 0 - the value is correct
- 1 - the value has been recovered

- 2 - the value is suspect as to the observations
- 3 - the value has been rejected
- 4 - no observations have been made
- 5 - the phenomenon did not occur
- 6 - according to the quality control algorithms the value is suspect
- 7,8 - reserve
- 9 - no quality control has been applied

Ship hydrometeorological data

- 0 - no control
- 1 - the value is correct
- 2 - the parameter is inconsistent with other parameters
- 3 - the value is suspect
- 4 - the value is erroneous
- 5 - the value has been changed as a result-of control
- 6,7,8 - reserve
- 9 - the parameter value is missing

List of requirements for oceanographic data intended for international exchange can be compiled as follows:

- 1 The data which are exchanged must be accompanied by documentation describing the data structure, containing information on their volume, their relation to an international project, the name and the address of the data originator.
2. The, data set descriptive characteristics must contain the following information: space-time coordinates of each observation, type of the platform, dimensionality of the parameter, measurement technique used and instrument type.
3. Results of oceanographic-measurements and computations in the form of values of hydrophysical and marine meteorological parameters with corrections for instrumental errors must go into international exchange.
4. The parameter values must be given to an accuracy corresponding to the instrument certificate characteristics and the possibilities of analyses techniques.
5. The values of each measured or derived parameter must be supplied with one of **the three quality flags**: - valid, suspect, rejected.

SECTION 2.4

ANNEXES

FORMALISED DESCRIPTION OF QUALITY CONTROL ALGORITHMS

SECTION 2.4, ANNEX 1: CHECKING THE ORDERING OF THE OCEANOGRAPHIC STATION DEPTHS

The author's code of the algorithm: RANG

Function: It is designed for verification of the proper order of the values (increasing with depth). It was used for cruise data checking.

The description of the algorithm:

$$S_{n, n-1} = H_{n-1} < H_n < H_{n+1} \quad (1.1)$$

where: n - depth number (from 1 through 99); H - observed depth, m.

Input data: a set of station depths.

Output data: a set of error-flagged data.

The originating country and organisation: the USSR, the VNIIGMI-WDC.

The full name of the document where the algorithm has been published:

A set of programmes for control and editing of cruise water-bottle data: the programme description /VNIIGMI-WDC, Goskomgidromet, OFAP. Ye.D. Vyazilov, G.I. Prolisko. Ye.N. Saveiko, M.N. Khvostova, M.I. Kabanov, IN. Zemlyanov - N 0432, Obninsk, 1987.

SECTION 2.4, ANNEX 2: CHECK OF COMPLETENESS

A.2.1 Check for the availability of oceanographic station depths

The author's code of the algorithm: POL 1.

Function: It is designed for detecting stations with missing 0 meter level depths.

The field of application: the processing of water-bottle data.

The description of the algorithm:

$$H_l = 0, n = 3 \quad (2.1)$$

where: n - level depth number; H - observed level value.

Input data: a set of station level depths.

Output data: a list of stations which do not satisfy the conditions.

The originating country and organisation: the USSR and the VNIIGMI-WDC.

The full name of the document where the algorithm has been published:

L.A. Golovanova. The description of a set of programmes for climatological and statistical computer processing of water-bottle data and their archival, VNIIGMI-WDC Proceedings, 1976, No. 33, pp. 32-57

A.2.2 Completeness of data collection

The author's code of the algorithm: POL 2.

Function: checking of digital data collection completeness.

The description of the algorithm:

$$R_d = R_e \quad (2.2)$$

where: R_d is the number of the digital values collected; R_e is the number of digital values to be computed using the initial time, the end time and the sampling interval.

Input data: oceanographic data represented in digital form (observation data series).

Output data: observation data series with "error control flag".

The originating country: United Kingdom.

SECTION 2.4, ANNEX 3: ESTIMATING INTERPOLATION CAPABILITIES OF OCEANOGRAPHIC PARAMETERS

The author's code of the algorithm: POL-N1

Function: It is designed for estimating the possibilities of oceanographic parameters interpolation onto standard depths if they are missing.

The description of the algorithm:

$$H_{n+1} - H_n < H_{n+3}^{standard} - H_n^{standard} \quad (3.1)$$

where: n - level number; H - observed level, m; $H^{standard}$ - standard level, m.

The originating country and organisation: the USSR, the VNIIGMI-WDC.

The full name of the document where the algorithm has been published:

A set of control and editing programmes for cruise water-bottle data: the programme description /VNIIGMI-WDC, Goskomgidromet, OFAP. Ye.D. Vyazilov, G.I. Prolisko, Ye.N. Saveiko, M.N. Khvostova, M.I. Kabanov, I.V. Zemlyanov - N 0432, Obninsk, 1987

The author's code of the algorithm: POL-N2

The algorithm description:

a) $d_1 \leq 400m; \quad d_2 < d_1 + 200m; \quad (3.2)$

b) $400 < d_1 \leq 1200; \quad d_2 \leq d_1 + 400; \quad (3.3)$

c) $d_1 \geq 1200m; \quad d_2 \text{ any one} \quad (3.4)$

d_1 - depth of the uppermost observation

d_2 - depth of the lowest observation

The originating country and organisation: the USA, NODC

The name of the document where the document has been published:

User's guide to NODC's data services. Key to oceanographic records documentation NI. U.S. Dept. of Commerce, NODC of NOAA. -Washington, D.C., 1974 - 72p.

Input data: 1. Observed depth oceanographic stations. 2. A set of standard depths.

Output data: A list of depths between which interpolation is impossible.

SECTION 2.4, ANNEX 4: DATA VALIDITY CHECK

A.4.1 Checking against physically valid limits

The author's code of the algorithm: LIMMAX, LIMMIN, OMINT, OMITS, OMAXT, OMAXS.

Function: It is designed for comparison of the observed values with physically valid limits of geophysical parameter values at one of the level depths.

The description of the algorithm:

$$X_{min} > X > X_{max} \quad (4.1)$$

Boundary conditions: in Table A.2.1 the values of variability limits of temperature, salinity and other hydrometeorological parameters for the whole World ocean are presented.

Input data: the observed values of water temperature, salinity and other hydrometeorological parameters.

Output data: validity and rejection flags for each parameter value.

The originating country and organisation: the USSR, the VNIIGMI-WDC.

The full name of the document where the algorithm has been published:

I.M. Belkin. Semantic control of oceanographic stations. - M. Gidrometeoizdat. VNIIGMI-WDC Proceedings, 1984, NI 13, pp.99-108.

Table A.4.1 Limiting values of parameters (physical oceanography)

Parameter	Limits
Identification information	
Latitude	From 0.00 to 90.00
Longitude	000.00 - 180.00
Year	1872-2000
Month	01-12
Day	01-31
Time (beginning and end of station/series etc.)	00.00 - 24.00
Depth to sea bottom, tens of meters	00000 - 11000
Ship hydrometeorological and wavemeter observations	
Water transparency, m	00-70
Water colour, scale	01-21
Wind direction, degs	000-360
Wind speed, m/s	00-80
Wave type, code	0-8
Wave shape, code	0-3
Description of sea state, numbers	0-9
Sea state, numbers	0-9
Wave direction, degs	000-360
Wave height, m	00-40
Wave length, m	00-500
Wave period, s	00-30
Visibility, km	0.1 -90.0
Air temperature, °C	- 50.0 + 50.0
Absolute humidity, mb	0.001 - 123.0
Relative humidity, >	001 -100
Air pressure, mb	700.0 - 1100.0
Present weather (WW), code	00-99
Total cloud amount, tenths	0-10
Cloud genera, code	0-10
Sunshine characteristic, code	1-3
Ice type, code	00-37
Ice shape, code	51-78
Past ice amount, tenths	0-10
Floating ice amount, tenths	0-10
Direction to ice edge, degs	000-360
Distance to ice edge, km	00-50

Table A.4.2 Temperature and Salinity Limiting Values

Layers of depth	Temperature, °C		Salinity ‰	
	min	max	min	max
0 - 50	-3.0	35	0	47
51 - 100	-3.0	30	1	40
101 - 400	-2.5	28	3	40
401 - 1100	-2.0	27	10	40
1101 - 3000	-1.5	is	22	38
3001 - 5500	-1.5	7	33	37
5501- 12000	-1.5	4	33	36.3

Table A.4.3 Water temperature and salinity limiting values for some of the seas

Sea	Temperature, °C		Salinity ‰	
	min	max	min	max
Azov	-1.0	33	0	20
Aral	-1.0	34	0	19
Baltic	-1.0	29	0	23
White	-2.0	28	0	35
Caspian	-1.5	36	0	17
Okhotsk	-2.0	27	0	35
Black	-1.5	32	0	23
Japan	-2.0	27	0	36
Red	5.0	42	0	46
Mediterranean	0.0	38	0	40

Table A.4.4 Refined limiting values of hydrochemical parameters

Parameter name	Refined limits	
	min	max
O ₂ , ml/l	0.0	19.0
O ₂ , %	0.0	190.0
PH, unit	7.4	8.4
Alkalinity, mg-eq/l	1.0	4.3
P ₀₄ , mcg/l	0.0	1500.0
P _{total} , mcg/l	0.0	250.0
SiO ₃ , mcg /l	0.0	25000.0
NO ₂ , mcg/l	0.0	1300.0
NO ₃ , mcg /l	0.0	3000.0
NH ₄ , mcg /l	0.0	8900.0
N _{org} , mcg/ l	0.0	400.0
Oxidizability, mcg/l	0.0	99.0
N _{total} , mcg/l	0.0	2500.0
chlorophyll, mcg/l	0.0	700.0
pheophytin	0.0	40000.0
H ₂ S, Ml/l		

A.4.2 Direction of wave propagation

The author's code of the algorithm: KNVOLNA

The description of the algorithm:

$$|\theta_1 - \theta_2| \leq 15^\circ \quad (4.2)$$

where: θ_2 is the general direction of wave propagation with high frequency; θ_1 - wind direction

$$\text{For wind waves} \quad |\theta_{ww} - \theta_1| \leq 30^\circ \text{ (with spectral peak)} \quad (4.3)$$

$$|\theta_{ww} - \theta_1| \leq 50^\circ \text{ (with other frequencies)} \quad (4.4)$$

Input data: wave direction

Output data: indicators of suspect or valid sampling

A.4.3 Current velocity

The author's code of the algorithm: KVTECHENIE

The description of the algorithm: the current velocity must not exceed the maximum speed which can be measured with the given current meter considering the period of operation and scale factor or 4 m/s irrespective of which one is smaller. The minimum current velocity must be 0 m/s.

$$0 \text{ m/s} \leq V \leq 4 \text{ m/s} \quad (4.5)$$

Input data: input current velocities

Output data: suspect and valid data indicators.

A.4.4 Sea level. "Coarse" limits

The author's code of the algorithm: KUROVEN

The description of the algorithm: maximum limits (amplitude HAT - LAT) (1.25 x mean amplitude of the storm surge for 100 years). For the Great Britain waters the maximum amplitude of the storm surge is 4m. Hence, the limits are defined as follows:

$$(LAT \text{ below } ML - 2.5\text{m}) \leq WL \leq (HAT \text{ above } ML + 2.5) \quad (4.6)$$

where: ML is the mean level, WL is the level to be determined; LAT is the minimum low tide level; HAT is the maximum high tide level.

A.4.5 Sea level. Control limits

The author's code of the algorithm: KKUROV

The description of the algorithm: the control limits are defined by the relation:

$$(LAT \text{ below } ML) < WL < (HAT \text{ above } ML) \quad (4.7)$$

where: LAT is the minimum low tide level; ML - mean level; HAT maximum high tide level; WL - the level to be determined.

A.4.6 Tide amplitude check

The author's code of the algorithm: KPRILIV

The description of the algorithm: this algorithm is meant for keeping the scale unchanged or matching two data series.

The tide amplitude between consecutive maxima and minima must lie in the range between the minimum quadrature tide and the maximum syzygial tide (HAT - LAT).

Hence:

$$\begin{array}{l} \text{maximum} \\ \text{amplitude of} \\ \text{quadrature tide} \end{array} \leq \begin{array}{c} |h_{\max} - h_{\min}| \\ \text{or} \\ |h_{\min} - h_{\max}| \end{array} \leq \text{Amplitude HAT - LAT} \quad (4.8)$$

where: hmax and hmin - consecutive maxima of water level. If the values are outside the limits the second value is supplied with a quality control flag.

A.4.7 Maximum and minimum levels time

The author's code of the algorithm: KTPRILIV

The description of the algorithm: for most cases the time difference between consecutive h_{\max} and h_{\min} and h_{\min} and h_{\max} must lie between $4 \frac{1}{4}$ and $8 \frac{1}{4}$ hours.

Thus:

$$4 \frac{1}{4} \leq \begin{array}{c} |Th_{\max} - Th_{\min}| \\ \text{or} \\ |Th_{\min} - Th_{\max}| \end{array} \leq 8 \frac{1}{4} \quad (4.9)$$

$Th_{\max} - Th_{\min}1$

$T_{\min} - T_{h_{\max}}$ where: $T_{h_{\max}}$ and t_{\min} are times of consecutive maximum and minimum water levels.

If the values are outside the limits the second value is supplied with a quality control flag.

Input data: sea level measurements.

Output data: quality indicators for sea level measurements and times of its maximum and minimum.

The originating country: United Kingdom.

SECTION 2.4, ANNEX 5: CHECKING FOR REALISTIC PHYSICAL RELATIONSHIPS

The author's code of the algorithm: SIGMA

Function: It is designed for identifying disturbances in the vertical distribution of density with depth at one oceanographic station (at standard depths).

The description of the algorithm:

$$(\sigma_n - \sigma_{n+1}) \leq 0.1 \quad (5.1)$$

where: σ_n - conditional density at n_m depth; σ_{n+1} - conditional density at the next depth.

The conditional density is calculated by empirical formula, depending on the World Ocean region.

Input data: values of conditional density and depth.

Output data: validity and rejection flags for temperature and salinity values.

The originating country and organisation: VNIIGMI-WDC and the USSR.

The full name of the document: D.M. Filippov. Algorithm for computerised climatological and statistical processing of water-bottle data. Gidrometeoizdat, Proceedings of VN11CM1-W13C, 1976, No 33, pp.5-31.

SECTION 2.4, ANNEX 6: CHECKING OF CONSISTENCY IN DIFFERENT PARAMETER VALUES

A.6.1 Water freezing temperature

The author's code of the algorithm: TMIN

Function: It is designed for identifying the agreement of the calculated water freezing temperature at a given salinity with the observed temperature value at one oceanographic station.

The description of the algorithm:

$$\tau = -0.0137 - 0.05199 \cdot S - 0.00007225[S]^2 - 0.000758 \quad (6.1)$$

$$\tau = -0.036 - 0.499S - 0.0001125S^2 - 0.00759P \quad (6.2)$$

for salinity $S=27-35 \text{‰}$;

where: T - observed water temperature; S - water salinity; z - depth, m; P - hydrostatic pressure; r water freezing temperature.

Input data: temperature, salinity and depth values.

Output data > validity and rejection flags for temperature and salinity values.

The originating country and organisation: the USSR and VNIIGMI-WDC.

A.6.2 Checking of the wave steepness

The author's code of the algorithm: KVOLN

Function: checking of the agreement of the calculated wave height and period values.

The description of the algorithm:

$$H_s > T_z^2 \leq 0.22 \quad (6.3)$$

where: H_s - wave height; T_z - wave period.

Quality flags should be set for those values for which manual inspection of the data is required.

The originating country: United Kingdom.

SECTION 2.4, ANNEX 7: STATISTICAL CONTROL OF DATA

A.7.1 Data control according to Smirnov - Grubbs criteria

The author's code of the algorithm: Smirnov - Grubbs.

Function: It is designed for testing the null hypothesis (H_0) of homogeneity of the oceanographic parameter sampling x_1, \dots, x_n . The testing is applied to several oceanographic stations of the same geographical region for the same depth according to Smirnov - Grubbs and Dixon criteria.

The description of the algorithm:

$$SG = \frac{\max |x_i - \bar{x}|}{S} \quad (7.1)$$

$$Di = \frac{y_n - y_{n-1}}{y_n - y_1} \quad (7.2)$$

where: \bar{x} - mean value in the sample; $\max |x_i - \bar{x}|$ - maximum modulus of deviation from the mean value; S > root-mean square deviation of the sample.

$$S = \sqrt{\frac{\sum (x_i - \bar{x})^2}{n-1}} \quad (7.3)$$

y - the values of x_i to which $\max (x_i)$ and $\min (x_i)$ correspond;
 y_{n-1} - the value of x_i nearest to the value of y_n .

Boundary conditions:

$$X_i > f(DAY_i) + E_i \quad (7.4)$$

where: DAY_i - the day number in the year; E_i the - deviation from annual variations.

H_0 testing is realised against the sampling.

The originating country and organisation: the USSR, VNIIGMI-WDC.

The full name of the document, where the algorithm has been published:

1. L.N. Bolshev, N.V. Smirnov. Tables of mathematical statistics. Moscow. "Nauka", 1983, pp.415.
2. W.J. Dixon. Processing data for outliers. Biometrics, 1953, vol. 9, pp.74-89.
3. A.A. Lykov. A set of programmes for calculation of annual water temperature variations. VNIIGMI-WDC Proceedings, 19859 No 123, pp. 77-81.

A.7.2 Wavemeter observations. Data validity

The author's code of the algorithm: VOLNA

Function: Data validity check in one sample.

The description of the algorithm:

$$|T_o - T_{cp}| \geq 25\text{sec.} \quad (7.5)$$

$$|A_8 - A_{cp}| \geq 0.2m. \quad (7.6)$$

$$|\sigma_8 - \sigma_{cp}| \geq 0.4 \text{ m} \quad (7.7)$$

where: T_o - current zero wave period; T_{cp} - mean sampling period; A_8 - one mean value in eight equal segments, into which the wave sampling is divided; A_{cp} - mean value of the entire sample; σ_8 one standard deviation in eight segments, into which the wave sample is divided; σ_{cp} - standard deviation, calculated for the entire sample.

Input data: wave sample.

Output data: "Data Error Flag" is set for the segments of the wave sample.

The originating country: United Kingdom.

A.7.3 Wavemeter observations. Check limits

The author's code of the algorithm: PREDEL

Function: It is designed for identifying values greater than statistical check limits.

The description of the algorithm:

$$H_o \geq 4\sigma \quad (7.8)$$

$$H_{\sigma p} \geq 8\sigma \quad (7.9)$$

where: σ - root-mean square deviation, where: H_o - the value of "Data Error Flag" parameter; $H_{\sigma p}$ rejected value.

Input data: wavemeter observation set.

Output data: quality flags for individual points of the set.

The originating country: United Kingdom.

SECTION 2.4, ANNEX 8: CHECKING OF THE VERTICAL TEMPERATURE AND SALINITY DISTRIBUTION

The author's code of the algorithm: GRAD

Function: It is designed for identification of disturbances in the vertical distribution of temperature and salinity with depth at one oceanographic station.

The description of the algorithm:

$$\left| T_m - \frac{T_{m+1} + T_{m-1}}{2} \right| - \left| \frac{T_{m-1} - T_{m+1}}{2} \right| < \Delta T \tag{8.1}$$

$$\left| S_m - \frac{S_{m+1} + S_{m-1}}{2} \right| - \left| \frac{S_{m-1} - S_{m+1}}{2} \right| < \Delta S \tag{8.2}$$

where: T,S - values of temperature and salinity; m level depth number.

Boundary conditions: T=2.0°C, S=0.1‰.

Input data: the oceanographic station temperature and salinity values.

Output data: the flags of suspect values for two level depths.

The originating country: FRG

The full name of the document where the algorithm has been published: Guide to operational procedures for the collection and exchange of oceanographic data (BATHY and TESAC) IOC, UNESCO, 1984, Manuals and Guides No3.

SECTION 2.4, ANNEX 9: CHECKS BASED ON INTERPOLATION

The author's code of the algorithm: GMAX

Function: replacement of an individual data point which failed certain tests. The interpolation condition is defined.

The description of the algorithm:

$$\Delta G > \Delta G_{\max} \quad (9.1)$$

$$\Delta G_{\max} = \left[\sigma S_{\max} \pi \left(\log_e \left(\frac{T \sqrt{g S_{\max}}}{8 \pi \sigma} \right) \right) \right]^2 \cdot \Delta t \quad (9.2)$$

$$\Delta > 6\sigma \quad (9.3)$$

where: ΔG is deviation of the current value from the mean; σ is standard deviation; S_{\max} is maximum allowable wave steepness (1/5); T is record length; Δt is sampling interval.

Input data: wave gauge record of 1024 seconds sampled at 2Hz.

Output data: points to which interpolation is to be carried out to remove single spikes.

Originating country: United Kingdom.

SECTION 2.4, ANNEX 10: CHECK OF THE OCEANOGRAPHIC PARAMETER RATE OF CHANGE

Function: It is designed for detecting errors in oceanographic parameter measurements.

A.10.1 Water temperature and conductivity (salinity)

The author's code of the algorithm: VTEMP, VSOL

The description of the algorithm:

$$|T_1 - T_2| \leq \Delta t / 60^\circ C \quad (10.1)$$

where T_1 and T_2 are consecutive temperature measurements and Δt is the sampling interval in minutes.

Conductivity (salinity)

$$|S_1 - S_2| \leq \Delta t / 60^\circ ppt \quad (10.2)$$

where S_1 and S_2 are consecutive salinity measurements and Δt is the sampling interval in minutes.

Input data: water temperature and conductivity (salinity) measurements.

Output data: quality flags for individual values of sea water, T°C and S‰.

A. 10.2 Check of level rate of change

The author's code of the algorithm: VUROV

The description of the algorithm: The theoretical differences between consecutive samples h_1 and h_2 for various sample speed t , assuming semidiurnal tidal current with a period of 12, 42 hours are given in Table A.10.1.

Input data: measured level values.

Output data: quality flags for sea level samples.

The originating country: United Kingdom.

Table A.10.1 Theoretical differences between consecutive samples

t min	Theoretical difference $h_1 - h_2$	Allowable difference $h_1 - h_2$
10	0.0843 A	0.05 (HAT-LAT)
15	0.1264 A	0.08 (HAT-LAT)
20	0.1685 A	0.10 (HAT-LAT)
30	0.2523 A	0.15 (HAT-LAT)
60	0.5001 A	0.30 (HAT-LAT)

where: A is the tidal amplitude. The allowable differences, given above, are based on an amplitude 0.5 (HAT - LAT) with a 20% increase to account for asymmetry in the tidal curve.

Quality flag is set to the second sample, h_2

SECTION 2.4, ANNEX 11: ESTIMATING OF THE PERMISSIBLE OCEANOGRAPHIC STATION CO-ORDINATE DIFFERENCE

The author's code of the algorithm: RAST, RAST 1

Function: It is designed for estimating the permissible oceanographic station co-ordinate difference versus the vessel speed.

The field of application - checking cruise data sets,

The description of the algorithm: formulae:

$$S_{n, n-1} > V(t_n - t_{n-1}) \quad (11.1)$$

where: $S_{n, n-1}$ - distance between two successive stations of the cruise, miles; $t_{n, n-1}$ - time between successive stations, hours; V - vessel speed, knots.

$$S_{n, n-k} = \sqrt{(a \Delta \varphi_k)^2 + \Delta \lambda_k^2 \cdot 60 \text{ miles/degrees}} \quad (11.2)$$

$$a = \text{COS}(|\varphi_1 - \varphi_2| / 2) \quad (11.3)$$

where: $S_{n, n-k}$ - distance between the successive stations, miles; $\Delta \varphi_k$ - difference in latitudes between the successive stations, degrees; $\Delta \lambda_k$ - difference in longitudes between the successive stations, degrees.

Input data: the set of cruise oceanographic stations chronologically ordered.

Output data: the controlled set of oceanographic stations.

The originating country and organisation: the USSR, the VNIIGMI-WDC.

The full name of the document where the algorithm has been published:

A set of control and editing programmes for cruise water-bottle data: the programme description /VNIIGMI-WDC, Goskomgidromet, OFAP. Ye.D. Vyazilov, G.I. Prolisko, Ye.N. Saveiko, M.N. Khvostova, M.I. Kabanov, IN. Zemlyanov - N 0432, Obninsk, 1987

SECTION 2.4, ANNEX 12: CHECK OF OCEANOGRAPHIC DATA CONSISTENCY

Function: It is designed for detecting erroneous oceanographic parameter measurements.

A.1 2.1 Non-directional waves

The author's code of the algorithm: CVOLNA

The description of the algorithm:

$$H_1 > H_2 = \dots = H_{10} \quad (12.1)$$

Occurrence of 10 and more consecutive points with similar values of wave height.

Input data: wave records

Output data: quality flag for sample

A. 12.2 Current speed

The author's code of the algorithm: CTECHEN

The description of the algorithm: constant current speed is uncommon, although theoretically two consecutive values may be the same.

A quality flag should be set against each current speed data point, which is equal to the two previous values regardless of the sampling interval.

$$V_1 > V_2 > V_3 \quad (12.2)$$

where: V - current speed

Input data: current speed measurements

Output data: quality-flags for separate current speed values.

A.1 2.3 Current direction

The author's code of the algorithm: CNTECH

The description of the algorithm: almost constant current direction can be generated by topographic effects, although actual direction constancy will depend also on the resolution of the current meter compass and the sampling interval.

The following numbers of consecutive equal values (direction) are allowed, depending on sampling interval:

Table A.12.1 Dependence of the number of consecutive equal values on sampling interval

t (min)	Number of consecutive equal values
5	12
10	6
15	4
20	3
30	2
60	2

A flag should be set against each current direction data point, which is equal in value to the previous 12, 6, 4, 3 or 2 previous values (as applicable).

Input data: current direction measurements

Output data: quality flags for separate current direction values

A. 12.4 Temperature and salinity

The author's code of the algorithm: CTEMP, CSOL

The description of the algorithm:

$$T = 24 \cdot \frac{60}{\Delta t(\text{min})} \quad (12.3)$$

where: T - allowable number of consecutive equal values; t - the sampling interval in minutes.

Input data: sea water temperature and salinity measurements.

Output data: quality flags for sampling T°C and S‰.

A. 12.5 Hydrostatic pressure

The author's code of the algorithm: CDAV

The description of the algorithm: the number of allowable consecutive values depends on the sampling interval.

Table A.12.2 Dependence of the number of consecutive equal values on the sampling Interval

t (min)	Number of allowable consecutive equal values
5	24
10	12
15	8
20	6
30	4
60	2

This implies that stationary up to 2 hours is allowed, but anything exceeding this is flagged.

Input data: hydrostatic pressure measurements.

Output data: quality flags for the sampling intervals.

A. 12.6 Level

The author's code of the algorithm: CUROV

The description of the algorithm: Theoretically for a sine or cosine curve a maximum number of two consecutive samples can have the same value (assuming that there are no erroneous values). However, in practice, the number of consecutive equal values depends on the tidal range and nature of the tidal curve at a site, the resolution of the tide gauge and the sampling interval. Suggested numbers of consecutive equal values allowed depending on the sampling interval are:

Table A.12.3 Dependence of the number of consecutive equal values on the sampling Interval

t (min)	Number of allowable consecutive equal values
10	12
15	8
20	6
30	4
60	2

This Table implies that stationarity of up to 2 hours is allowed but any periods exceeding this are flagged.

Input data: level measurements

Output data: quality flags for samples.

The originating country: United Kingdom

SECTION 2.5

IN THE PURSUIT OF HIGH-QUALITY SEA LEVEL DATA

Bernard J Kilonsky
Patrick Caldwell

Reprinted from
IEEE OCEANS PROCEEDINGS
Vol. 2, October 1-3,1991

IN THE PURSUIT OF HIGH-QUALITY SEA LEVEL DATA

Bernard J Kilonsky
TOGA Sea Level Center
University of Hawaii, MSB 317
1000 Pope Road 1000
Honolulu, Hawaii 96822

Patrick Caldwell
Joint Archive for Sea Level
University of Hawaii, MSB 316
Pope Road
Honolulu, Hawaii 96822

Abstract

The Indo-Pacific Sea Level Network consists of an array of sea level gauges installed in harbors or lagoons of tropical islands and along the continents. Most stations were installed by the University of Hawaii, which also collects, processes, and archives the data. The Tropical Ocean-Global Atmosphere Sea Level Center receives data from this network and other stations in the region operated by national agencies. The steps essential to producing high-quality sea level information and their specific application to the TOGA permanent data archive are depicted. The sea level data processing techniques used by the joint Archive for Sea Level will be examined to demonstrate quality control methodology. The processing of the data involves the use of standardized formats and quality control management to insure the scientific validity of the data. Emphasis is on the timing of the samples and the linking of the data to a reference level. These procedures produce high-quality data at hourly, daily, and monthly intervals for the permanent archive at the World Data Centers, from which the sea level data are available to the scientific community for exchange and analysis.

INTRODUCTION

The sea-surface topography (sea level), the integrated indicator of a broad range of physical processes, is one of the fundamental quantities in oceanographic and geophysical research. In the higher frequencies, it is dominated by surface waves, tides, and occasionally tsunamis. Slower variations are associated with ocean circulation patterns and short-term climatic changes. Extended time series of sea level will eventually result in information about the relative variations of land and sea, tectonic changes, and the adjustment of water and ice volumes.

The potential of sea level observations for the interpretation of ocean dynamics and the associated linkage to weather and short-term climatic variations was identified by Wyrтки in 1973.¹ This led to the establishment during the North Pacific Experiment (NORPAX) of a network of gauges in the equatorial Pacific to study the potential of sea level observations for ocean monitoring.² This newly created network was successfully used to monitor the large water-mass displacements during the 1976³ and the 1982-83 El Niño events.⁴

The NORPAX stations were originally developed through grants from the National Science Foundation (NSF), and a lifetime of ten years was projected. However, the information derived from the network has proved to be sufficiently important for the monitoring, analysis, and understanding of oceanic processes that the Tropical Ocean-Global Atmosphere project (TOGA) with joint support from NSF and the National Oceanographic and Atmospheric Administration (NOAA) continued its operation, and additionally established the International TOGA Sea Level Center (SLC) to concentrate the efforts of acquiring, processing, and archiving data in the tropics. As the quantity of data collected by the TOGA SLC increased, expertise in data management was provided by the National Oceanographic Data Center (NODC) with the establishment of the joint Archive for Sea Level (JASL) at the University of Hawaii (UH) in 1987.

The effects of the oceans on climate, specifically the effects of El Niño on weather, dramatically increased the demands for timely sea level data, and directly led to the production of synoptic maps of sea level for the Pacific Ocean. As part of the effort to meet this requirement the University of Hawaii with the co-operation of the Pacific Tsunami Warning Center (PTWC) and the Atlantic Oceanographic and Meteorological Laboratories (AOML) has upgraded over 40 stations in the Pacific with the

installation of satellite platforms and redundant instruments.⁵ These upgraded sites not only enabled the University of Hawaii to provide real and near-real time data sets for the monitoring and analysis of oceanic events, but also provided PTWC with invaluable information on the generation and propagation of Tsunamis.

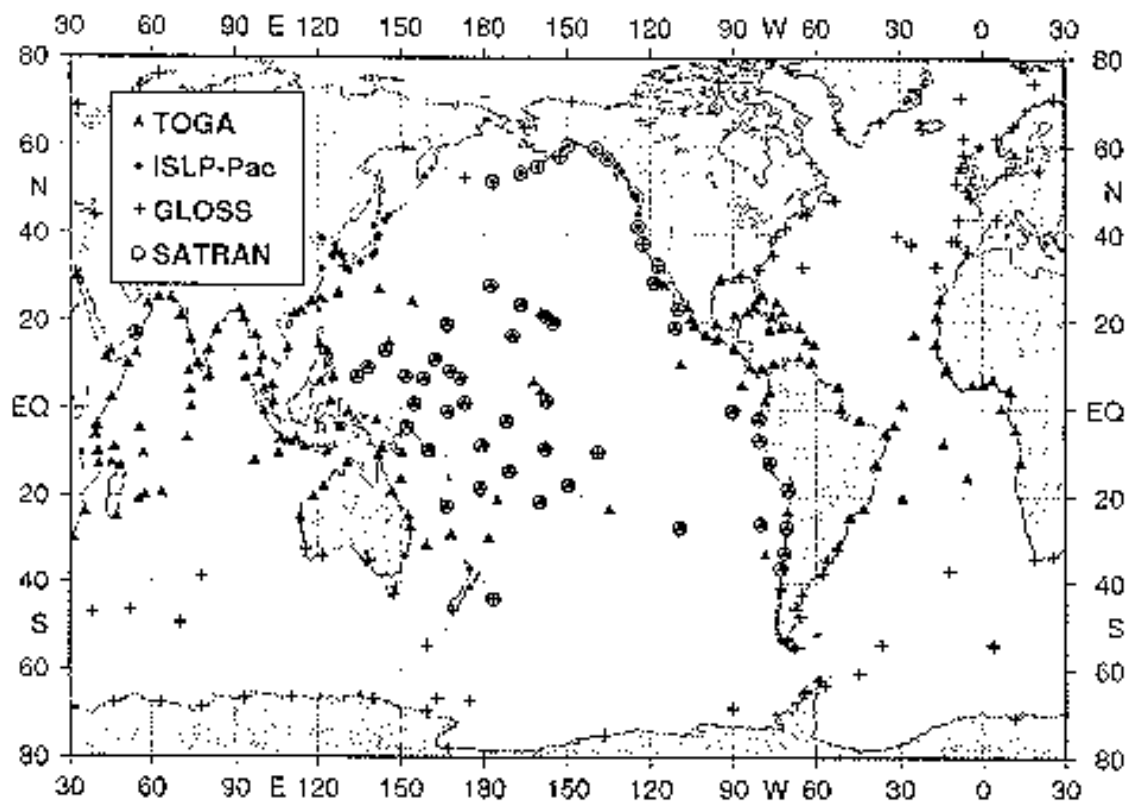

Figure 1. Sea Level stations within the TOGA, ISLP-Pac, and GLOSS networks. A circle around the station indicates that it transmits to the University of Hawaii over one of the geostationary satellites.

The success of the Pacific network has also spawned a similar network in the Indian Ocean, and since 1985 more than 20 sea level sites have been newly established or re-activated by the University of Hawaii. In co-operation with host country national agencies, a program is now underway to upgrade these sites with redundant sensors and satellite platforms. In the summer of 1991, the first upgraded station was installed in Salalah, Oman, and the near-real time data transmitted to the TOGA Sea Level Center at the University of Hawaii via the Global Telecommunication System (GTS) of the World Meteorological Organization (WMO).

With the onset of the World Ocean Circulation Experiment (WOCE) and the launching of satellites with altimeters capable of monitoring the sea surface topography, the Indo-Pacific Sea Level Network has attained a new dimension. Information from the network will provide ground truth for these satellites⁶ and allow independent checks on their results.⁷ The Indo-Pacific Sea Level network will also help form the basis for the establishment of the Global Sea Level Observing System (GLOSS) in the Indian and Pacific Oceans.⁸ With the development of new geodetic techniques based on very long baseline interferometric measurements (VLBI) and the Global Positioning System (GPS), the network will provide the capability to establish a global reference frame to link sea level measurements and obtain absolute measurements of global sea level for the first time.

This paper will focus on the methodology necessary to produce high-quality sea level data sets. First, the considerations in establishing the Indo-Pacific Sea Level Network are discussed. Then, the schemes of data acquisition, quality control, and assessment used by TOGA SLC and JASL personnel are detailed.

NETWORK DESIGN

The primary purpose of the Indo-Pacific Sea Level Network is to monitor the large-scale, long-period changes in the sea-surface topography of the tropical Indian and Pacific oceans. The network is physically constrained to land-based stations and was designed to take optimal advantage of island groups in both oceans. Studies have shown that there are various spatial and time scales over which sea level changes are significant.⁹ The spatial scales of the low-frequency sea level variations required only one gauge in each island group¹⁰ and at intervals not less than 1000 km along continental coasts.¹¹ Figure 1 shows the current and projected GLOSS and TOGA sea level stations.

INSTALLATIONS AND INSTRUMENTATION

During the planning for the network, it was decided that float-type gauges with standard stilling wells would be used as the primary sensor, and that the sea level information would be referenced via tide staffs using bench marks. The sea level gauges would be placed in harbors and on piers in lagoons where the installation would be protected. Other site criteria stipulated that the water be sufficiently deep, the station away from heavy ship activity, and the location be convenient for the tide observer and technicians and thus less costly to maintain. The use of shallow water pressure gauges was rejected for several reasons. They could not be easily referred to bench marks and the pressure transducers drifted, requiring costly calibration trips. In those few locations where a well installation was not feasible, bubbler gauges have been successfully installed.

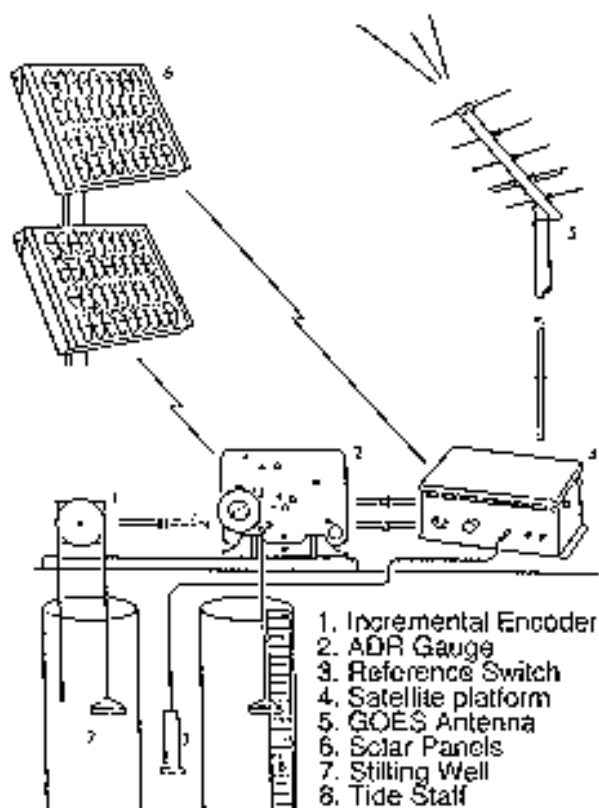

Figure 2. Typical Indo-Pacific sea level station installation.

Presently, the Indo-Pacific network stations are most commonly fitted with two or more redundant sensors to reduce data gaps, a data collection platform (DCP) with telemetry capabilities, electric power sources, and a weather-proof enclosure. The hub of each satellite-transmitting sea level station is the DCP, which manages the logging and transmission of the data from the various gauges. In addition, all stations include a tide staff and an automated reference level switch, which are linked by surveying with local bench marks, and used to align the gauge measurements with a common zero reference level (Figure 2). The different types of gauges installed within the Indo-Pacific Sea Level Network are analog-to-digital recorders, magnetic incremental shaft encoders, pneumatic devices, and pressure transducers.¹²

STATION MAINTENANCE

A local employee, who is trained on-site by University of Hawaii oceanographic technicians, is responsible for tide staff readings, and minor repairs and servicing. Because of the vastness of the Pacific basin, the remoteness of the island stations, and fiscal considerations, there is no fixed schedule of network maintenance. Only when necessary, will UH technicians visit the site for the repair of serious problems. Thus the local attendant is very important to the reliability of the installations. The use of a local employee also greatly reduces the occurrences of vandalism. Most installations are on small islands with limited populations, so a competent local attendant is usually able to identify culprits, recover any stolen materials, i.e. solar panels, and reinstall them to prevent station down-time. The technicians are responsible for all on-site installation decisions and for all surveying of tide staffs, switches, and bench marks.

REFERENCE LEVELS

For research in longer time and space scales, sea level data must be related to a very stable datum. In the Indo-Pacific Sea Level Network each station has its own local datum, defined by the zero of its tide staff, for the referencing of sea level heights. This zero reference has traditionally been established by linking a tide staff to a system of surveyed vertical control points. Visual staff readings and spot gauge data pairs are then used to statistically calculate the tide staff zero reference level correction constants. The University of Hawaii has developed an automated reference level switch that can be used at DCP sites. It produces reference level information that accommodates the improved performance of the modern tide gauge. This switch is surveyed directly into the existing benchmarks. It utilizes the microprocessor-based DCPs to produce very accurate reference level information.

TELEMETRY

The DCPs at remote sites transmit sea level data at precisely timed intervals and occasional special tsunami broadcasts via NOAA's Geostationary Operational Environmental Satellite (GOES) Data Collection System (DCS), Japan's Geostationary Meteorological Satellite (GMS) DCS, and the European Organization for the Exploitation of Meteorological Satellites (EUMETSAT) Meteorological Satellite (METEOSAT) DCS. At the programmed transmit time, the DCP radios are activated and the stored sensor data is phase encoded into a UHF carrier. The data is received by the GOES transponder and retransmitted in the S band to the National Environmental Satellite, Data, and Information Service (NESDIS) Command and Acquisition Facility at Wallops Island, Virginia. After demodulation, the platform messages are relayed to the National Weather Service (NWS) Telecommunication Gateway and routed to the TOGA SLC over NWS telecommunication lines where they are logged on a dedicated microcomputer. Although message formats vary among stations, they usually include at least two channels of sea level height, reference level switch information, and battery voltages and other DCP engineering information. Collection and processing steps are separated into daily and monthly routines. Data messages are normally received in Hawaii three to five minutes after transmission from the DCP.

DATA PROCESSING

The processing of sea level data is another function of the Indo-Pacific Network and the TOGA SLC. The methodology is formulated to produce a scientifically valid data set in a concise standard archive that can be readily exchanged or analyzed. Staff and students perform the systematic processing and archiving of the sea level data using a network of microcomputers. Data from various instruments are categorized by channel as shown in Table 1.

Table 1 Sea Level Data Channel Types

CHANNEL	GAUGE TYPE
ADR*	Leupold Stevens Analog-to-Digital Recorder
SDR	Leupold Stevens ADR
ENC	Handar Encoder
PRS	Pressure Transducer
BUB	Bubbler Pressure Sensor

* Received on punch paper tape, all other channels transmitted via satellite.

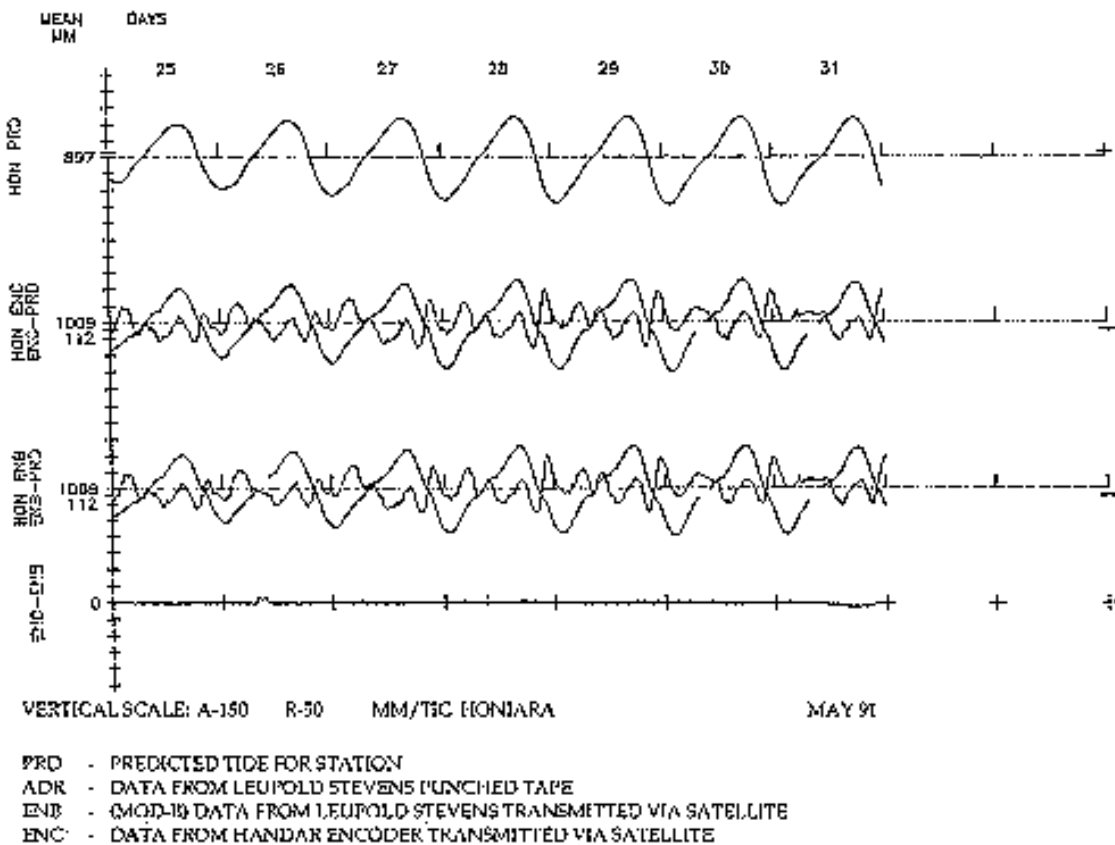

Figure 3. Nine day time section showing data, residuals, and differences for channel data.

The ADR data are normally very clean and need little operator intervention. However, several techniques are employed to insure their integrity. First differences of consecutive values are calculated and compared to threshold values. If a flagged value occurs, the paper tape is checked for miscoding, and if possible, corrected. Monthly time series plots of the original ADR data and the residuals between

the ADR and the predicted tides (PRD) for a station are analyzed for possible problems. Detectable errors can be categorized as random erroneous signals, reference level shifts, timing errors, and data gaps. All of these errors are most evident in the residual plots, and can be usually resolved to produce a quality data set.

The satellite-transmitted sea level data are logged at the TOGA SLC on a dedicated microcomputer. Processing operations are divided into daily, weekly, and monthly routines. A daily plot of the data is inspected for possible instrument or transmission failures. The weekly activities include examining the data quality and backing up the data. Finally, the monthly operations include inspecting the data for scientific validity and intermediate archiving.

The daily review of the satellite-transmitted data is essential. Instrument and platform failures are addressed in a timely manner, and unresolved problems passed to the UH technicians for repair action. A request for visual inspection can be given to the local observer, and if necessary, a visit to the station planned for the technician. Once a week, a summary of the time series plots is given to the TOGA SLC manager and director, and the teletype line messages uploaded over the network for archiving on magnetic tape.

After a complete month of data has passed the daily checks, monthly processing and quality control are carried through for one station at a time. A station file is created that contains data from all available channels and the predicted tides. It also contains reference level information for each channel and serves as the merging point for the punch paper tape and satellite data. From these files, time series plots of the data, residuals between the predicted tides and data, and differences between all available channels for a station are generated for overlapping nine-day time segments (Figure 3). The plots are examined for obvious errors, and when possible the data corrected.

As stated previously, the sea level data must be related to a very stable reference. It is during the monthly processing that the initial linking of the data to the tide staff is accomplished. A cumulative log of the reference level offset between the tide staff readings and the ADR gauge observations is received in the mail along with the ADR punch paper tape. The data from this log are used to create a statistical summary of the staff reading/gauge data pairs and to calculate the additive constant for the zero reference level. This correction is added to the header of the ADR data, and is used to compile intermediate daily and monthly means. The sea level data are not adjusted to tide staff zero until after the annual assessment of the reference level by TOGA and JAR staff. The channels of data transmitted over the satellite use an automated reference level switch that provides the exact time the ocean passes a surveyed level. Using this information, the level of the individual channels of data can be statistically related to the tide staff and benchmarks, and the additive correction developed. The repeatability of the level correction produced by this system is typically a few hundredths of a foot.

DAILY AND MONTHLY MEANS

One of the advantages the UH group has over some other collectors of sea surface topography is their active involvement in research. This is the best check on the scientific validity of a data set. Preliminary daily and monthly means are computed and time series plots of progressive fifteen-month periods are generated. These plots are used by the TOGA SLC director and scientist to provide a first look at the non-tidal variations of the sea level. The investigators can identify phenomena with time periods from days to months and monitor indicators of short-term climatic fluctuations such as the arrival time of an equatorial Kelvin wave at the west coast of America.

The monthly means of sea level are also used by the Special Oceanographic Center (SOC) for Mean Sea Level in the Pacific, which is co-located at the TOGA SLC, to produce near-real time synoptic maps of sea level as part of the Integrated Global Ocean Services Systems (IGOSS) Sea Level Program in the Pacific (ISLP-Pac) (Figure 4). The maps are published approximately 28 days after the end of the month. They are distributed to a mailing list of about 140 users, and are redistributed by the national contacts of several participating countries. The maps are also reproduced in the monthly Bulletin of the Climate Analysis Center of NOAA and in the monthly Bulletin of the World Climate Program published by the WMO.

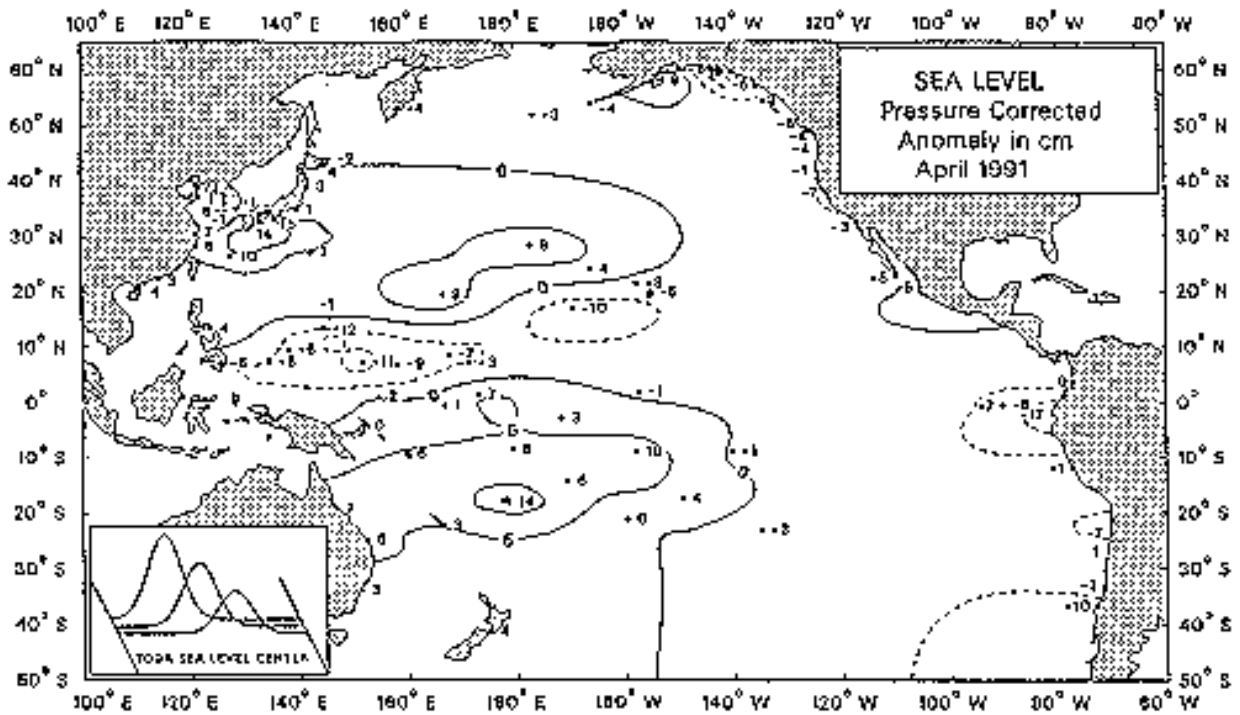

Figure 4. Anomaly of sea level (cm) for April 1991.

ANNUAL ASSESSMENT AND ARCHIVING

The final stage of data processing and the preparation for the permanent archive is performed at yearly intervals. The SLC director reviews the complete twelve months of data from the last calendar year and assigns the final referencing of the sea level heights to tide-staff zero. The basic assumption in selecting a constant offset is that the gauge data are stable, and that significant changes during a given year are normally associated with replacement or maintenance of the gauges or satellite platforms. Thus, the reference level of the data does not track the small month-to-month changes in the staff readings, but is only changed upon evidence that an incident has caused the level of the data to move in the vertical.

After the data from the Indo-Pacific stations have been leveled, values are calculated from a primary sensor that has minimal gaps by using a three point Hanning filter centered on the hour. Caps in the primary data Channel are replaced by data from the redundant sensors. This hourly data set is then added to the TOGA SLC permanent archive, and used by the JASL staff to produce daily and monthly values for distribution to other TOGA data centers, to the Permanent Service for Mean Sea Level (PSMSL), and to World Data Centers A and B for Oceanography.

JASL DATA PROCESSING

The hourly data sets form the focal point for quality assurance and assessment for all data sources. The hourly data generated from the Indo-Pacific network needs little quality control. However, data from the analog rolls and data received as hourly values from international sources require closer examination. Quality control involves the same steps taken with the high-frequency data. They include the replacement of obviously wrong data values and short gaps, correction of timing drifts, and maintenance of reference level stability. Checks begin with an examination of a plot of residuals. Obviously wrong data values are removed from the record. Timing errors of exact increments of one hour are corrected by shifting the data. Simple daily values and differences of these values with neighbouring stations are computed and plotted to monitor the stability of the reference level. These daily values are not archived. If a shift is suspected, the responsible agencies are informed and requested to investigate. If the agencies cannot provide information, obvious shifts are corrected with

the best available information and documented in the quality assessment. Unresolved shifts are also documented. If the reference levels on either side of a reference level shift are not linked by levelling to the same bench marks, the record for that station is broken into separate data sets. Upon completion of quality control for the hourly values, all data are relative to GMT and in millimeters.

Daily values are obtained using a two-step filtering operation. First, the dominant diurnal and semidiurnal tidal components are removed from the quality controlled hourly values. Secondly, a 119-point convolution filter centered on noon is applied to remove the remaining high-frequency energy and to prevent aliasing in the daily values. The 95, 50, and 5% amplitude points are 124.0, 60.2, and 40.2 hours, respectively. The Nyquist frequency of the daily data corresponds to period of 48 hours which has a response of about 6% amplitude, thus, aliasing is minimal. The primary tidal periods have a response of less than 0.1 % amplitude.

The filtering operation incorporates an objective procedure to handle gaps. This objective technique simply replaces the filter weight at any missing observation with a zero and renormalizes the sum of the modified weight function to unity. This technique is equivalent to interpolating the missing observation with an estimate of the local mean of the time series. The local mean is defined as the mean of a given segment of length equal to the length of the filter. The error associated with this technique can be estimated objectively and is used as a criterion for accepting or rejecting a daily value computed in an area of the time series which contains a gap or gaps. This error depends on the ratio of the standard deviations of the input (hourly) and the output (daily) data.

The monthly values are calculated from the daily data with a simple average of all the daily values in a month. If seven or fewer values are missing, the monthly value is calculated. The number of missing days for the calculation of each monthly value is also recorded.

JASL ASSESSMENT

A quality assessment is formed for each station based on the residuals of the hourly data. This information accompanies each data file in the permanent archive. The assessment includes general information such as station location, the contributor and originator, instrumentation, and processing notes, as well as the policy upon which the evaluation was made. A Completeness Index (CI) is defined as the percentage of days with data for each year. A Quality Index (QI) is defined as the percentage days in a year with available data that do not contain questionable fluctuations in the residuals. In general, fluctuations in the residuals are considered significant and are noted if the fluctuations are greater than 25 cm. However, each case is subjectively analyzed to determine if the fluctuation is a natural event, an indication of mechanical problems with the gauge or instrument setting, or a result of unreliable predicted tides. The predicted tides for locations with shallow water, river mouths, or complex coastal geometry and sea bottom topography can be unreliable if the harmonic analysis does not accurately compute all the necessary harmonic components. Such features are also noted in the quality assessments.

Since the daily and monthly data are derived from the quality controlled hourly data, the assessment based on the hourly data is also given in the permanent archive of daily and monthly values. The CI of the hourly data may be biased low for the daily and monthly data because of the gap handling characteristics of the 119-point filter.

THE JASL PERMANENT ARCHIVE

Hourly, daily, and monthly data constitute the permanent archive of sea level. For the tropical oceans, the archive presently contains 1516 station years of data from 177 stations. The data and quality assessments are stored digitally on magnetic tape. When the data have passed quality control and the assessments contain all the necessary general information, they are submitted to NODC. This submission occurs about 18 months after the calendar year in which the data were collected.

DATA REQUESTS

Send requests for data to:

The National Oceanographic Data Center
User Services E/OC21
1825 Connecticut Avenue, N. W.
Universal Bldg. Rm. 412
Washington, D. C. 20235 USA phone: 202-673-5549

Some stations may have unresolved problems. These data are retained at the TOGA Sea Level Center and may be obtained on a case-by-case basis. Send for these data and questions concerning data preparation and reports to:

The joint Archive for Sea Level c/o The TOGA Sea Level Center University of Hawaii 1000 Pope Rd. MSB
317 Honolulu, Hawaii 96822 USA phone: 808-956-6574

ACKNOWLEDGEMENTS

Support for the TOGA Sea Level Center has been provided under NOAA Co-operative Agreement NA85ABH00032. It is only with the expertise and enthusiastic support of the technicians who have installed and maintained the installations, the tide observers who have carefully taken tide staff readings, the computer programmers and data processors who have prepared the data, and the many agencies that have contributed data, that the network and center are a smoothly functioning reality. Dr Klaus Wyrтки is the director of the network and the center. Dr. Gary Mitchum provided helpful guidance in the development of the quality assessment criteria. The National Oceanographic Data Center provided an employee to perform quality control and assessment, and to prepare the final archive.

REFERENCES

- [1] K. Wyrтки, 1973. Teleconnections in the equatorial Pacific Ocean, *Science*, 180, 66-68.
- [2] K. Wyrтки, 1979a. Sea level variations; monitoring the breath of the Pacific. *EOS*, 60(3), 25-27.
- [3] K. Wyrтки, 1979b. The response of sea surface topography to the 1976 El Nino. *J. Phys. Oceanogr.*, 9, 1223-1231.
- [4] K. Wyrтки, 1985. Sea level fluctuations in the Pacific during the 1982-83 El Nino. *Geophys. Res. Letters*, 12(3), 125-128.
- [5] B. J. Kilonsky, 1984: Satellite-transmitted sea level stations - 1981. Ref. HIG-84-2, University of Hawaii, Honolulu, 40 pp.
- [6] K. Wyrтки, 1987. Comparing GEOSAT altimetry and sea level. *EOS*, 68(35), 731.
- [7] K. Wyrтки and G. Mitchum, 1990. Interannual differences of GEOSAT altimeter heights and sea level: the importance of a datum. *J. Geophys Res.* 95(C3), 2969-2975.
- [8] UNESCO, 1990. Global Sea Level Observing System (GLOSS) Implementation Plan. Intergovernmental Oceanographic Commission of UNESCO. IOC Tech. Ser. 35, SC-90/WS-39, Paris, 1990, 90 pp.
- [9] G. Mitchum and K. Wyrтки, 1988. Overview of Pacific sea level variability. *Mar. Geodesy.* 12, 235-245

- [10] K. Wyrтки, B. J. Kilonsky, and S. Nakahara, 1988a. The IGOSS pilot project in the Pacific. Univ. of Hawaii, JIMAR 88-0150, 59 pp.
- [11] D. Roach, G. Mitchum, and K. Wyrтки, 1989. Length scales interannual sea level variations along the Pacific margin. *J. Phys. Oceanogr.*, 19, 122-128.
- [12] K. Wyrтки, and P. Caldwell, K. Constantine, B. J. Kilonsky, G. T. Mitchum, B. Miyamoto, T. Murphy. and S. Nakahara, 1988b. The Pacific island sea level network. Univ. of Hawaii, JIMAR 88-0137, 71 pp.
- [13] P. Bloomfield, 1976. *Fourier Analysis of Time Series: An Introduction*. New York: John-Wiley and Sons. pp 129-137.

SECTION 2.6

Data Quality Control at the TOGA Subsurface data Centre

**report prepared by J P REBERT for the GTSP Workshop
(New-York January 1990)**

DATA QUALITY CONTROL AT THE TOGA SUBSURFACE DATA CENTRE

report prepared by J P REBERT for the GTSP Workshop
(New-York January 1990)

1. INTRODUCTION

The data arrive to the TOGA subsurface data Centre in two modes: in real time (transmitted monthly by the French IGOSS Centre) and in delayed mode (transmitted by TOGA VOS managers and data Centres). Most of the data are therefore loaded two times and must pass twice through the controls which are briefly described below.

These controls have been implemented at the beginning of the activity of TOGA Centre and had to be improved-or modified several times according to the bad results we had with the previous versions. They have not been modified since two years now, though we are aware of their deficiencies and drawbacks. But any attempt to improve them more, given the present scheme of the data base structure, lead to prohibitive data loading times.

A complete re-analysis of the controls has therefore been made, taken into account the experience gained with the present system, and should be implemented in the future version of the data management scheme. We give in annex the flow chart of this proposed new version of the controls (in French). We are expecting from the GTSP some firm conclusions on the common sets of controls which should be achieved by all the Centres, to add them in the new procedures.

2. PRELIMINARY CONTROLS

A) FORMAT CHECKING

Several formats are currently accepted: GF3, TSDC input format, IGOSS format, diverse submitted formats. If the format doesn't meet any of these format, the principles are:

- check the amount of reformatting necessary
- check if reformatting would be done by the submitted
- check the size and interest of this data set
- check if the data can be accessed or reformatted elsewhere
- take a decision and create a new submitted format or not

B) ENTRANCE CONTROLS

All the profiles not passing these tests are rejected in an auxiliary file where they can be recovered and corrected:

Date: Year lower than current year
Month between 1 and 12
Time: Day between 1 and 31
Hour between 0 and 23
Minute between 0 and 59
Position: Latitude between -30 and 30
Longitude between -180 and 180

Temperature always positive
Number of levels positive (at least one data)

Deficiencies: No control on depths (depths inversions are checked further. The profiles are cut at the first depth inversion). No control on the deepest level of the profile (10 meters and at least two levels seem to be the minimum acceptable requirement for TOGA data).

System drawback: The DBMS has no "DATE" type fields. Data collected in February 31 found. Needs complete programming.

C) TEMPERATURE RANGE CONTROLS

This test is applied to the deepest level of the profile. All the data trespassing these thresholds enter in the data base and are automatically flagged 3 (doubtful). The ranges have been chosen given the specificity of the TOGA area:

0 meter	12°C to 33°C
300 meters	6°C to 21°C
500 meters	4°C to 18°C
1000 meters	3°C to 10°C
2000 meters	1.5°C to 5°C
3000 meters	1°C to 3°C

Drawback: All the deep profiles in the Red Sea are flagged 3 and must be reflagged.

3. PRE PROCESSING DUPLICATE CONTROLS

Given the large amount of data exchanged and the terms of commitment of the TOGA Centre (replace the real time data by the delayed mode data), this represents the most complex part of the controls and the longest to achieve.

Basically there is strictly no way to automatically detect all the duplicates (we mean "not exact duplicates"), since the sources of errors are random and unknown. The aim is to minimise their number. The minimum acceptable level of duplication is unknown. The only limit is the maximum acceptable time that can be devoted to this task. We have therefore adopted the following principles:

- The duplicates should be eliminated before entering the data base
- The loading time of a data set must not exceed one night
- Better accept a duplicate than reject a non duplicate
- A delayed mode profile replaces a real time profile
- A real time profile doesn't replace a delayed mode profile
- A profile doesn't replace a profile of the same type
- The procedure is automatic

PRACTICAL RULES

To reduce the time of research of all the profiles which can duplicate, a first selection on keys is done for possible duplicate. The key contains the Ocean abbreviate and the 1 ' latitude/longitude square containing the profile. The profiles from this key and the contiguous ones are selected.

The comparison is done on date, time, position and type of profile, not on the data.

a) If the profile comes from an NODC data set and is composed of XBT or SBT.

- Transform the NODC vessels code into call sign using a cross reference table.
- If the call sign is not found, reject the profile in a temporary file where the call sign can be modified. If the call sign is not found after further investigations, it is replaced by a string composed of "NODC" and the NODC code.
- Begin the loading

b) If the call sign is not "SHIP"

- if the call signs are identical

- if year, month, day are identical
- if the difference in time is less than one hour

Profiles are considered as duplicates an XBT replaces the real time profile, otherwise the profile is rejected in an auxiliary file.

c) If the call sign is "SHIP"

- if year, month day are identical
- if the difference between latitude and longitude is less than .5"

Profiles are considered as duplicates Same rule applies and the call sign replaces "SHIP" if the data base profile was labelled 'SHIP'.

MAIN DEFICIENCIES OF THE PRESENT PROCEDURE:

This procedure eliminates more than 90% of the duplicates. But it is inadequate to detect the following discrepancies:

- Differences in call signs
- Large position error (more than 1° lat/long), quadrant errors
- Difference on year, month, day. Particularly bad detection of data collected around midnight

Furthermore this procedure rejects some non duplicate data which must be reloaded further without control: particularly XBT sent in time, sequential form where the first measurement is bad and repeated just after.

It is therefore safer to load small data set where the auxiliary files containing rejected XBT are not too large and can be carefully inspected. Anyway, during the loading, messages on causes of rejection are delivered for each rejection.

4. POST PROCESSING DUPLICATE CONTROLS

As the preprocessing of duplicates leaves in the data base some amount of redundant profiles and unknown call signs, we implemented additional duplicate controls which are achieved when large data sets have been loaded. These second sets of controls must be different from the first one, so their principle is based not on index but on sorting. These controls are currently done off line on a microcomputer in a two steps procedure.

PRINCIPLES

- select a yearly headers data set
- transfer it in a microcomputer DBMS

a) First step

- sort the data set on call sign and time
- scan the data set
- apply a speed test

Rules:

If two contiguous profiles for the same vessel are distant of

- less than 20 minutes in time
- less than 3 miles in distance
- or if speeds exceeds 25 knots
- and not sent by the same Institution

Then

- eliminate the real time profile if met by an XBT
- stop and wait for the operator's decision for profiles of the same type.
- Put all the deleted headers in a file for transfer to the main frame where the profile will be cancelled.

b) Second step

- sort the new header data set on time irrespective of the call sign
- scan with the following rules:

If two contiguous profiles are separated by

- less than 15 minutes
- less than 5 miles in latitude and longitude

Then

- same as before
- print all headers duplicating

c) Third step

If repeated duplications occur for two different vessels then put a filter on these vessels names and repeat the operation.

If two different vessels have been found to fully duplicate for some cruises, check and correct the headers in the data base and the cross reference table NODC code/call sign, inform the NODC of the decision taken and possible erroneous identifiers in their data.

Transfer the deleted header file on the main frame and cancel all profiles.

Remark: All the constants used above have been determined by experience, as representing the best compromise between speed/number of duplicates detected/number of non duplicates erroneously detected.

Advantages of this procedure: This procedure is very powerful:

- It regularly allows detection and suppression of 4% of duplicates in the data base which were not detected by the entrance procedure.
- It allows to detect unknown vessels and correct erroneous vessels identifiers (call sign)

We found that 2% of the Identifiers do not match in a merged real time delayed mode data base (100,000 profiles inspected)

Drawbacks of this procedure:

- Highly interactive therefore slow
- Doesn't look at the data therefore unable to choose the good profile in case of doubt.
- Needs a good knowledge of oceanographic data exchange problems from the operator and the origin of the errors that might have occurred, otherwise can be dangerous.

5. QUALITY CONTROLS AND DATA FLAGGING

A) PRINCIPLES

- The procedure is identical for delayed mode and real time data.
- Priority is given to the qualification of delayed mode data (real time data have been qualified at the French IGOSS Centre according to the procedures described in the IOC/WMO Manual 3), as the real time data will be further replaced by delayed mode one.

- Priority is given to data collected in the Atlantic and Indian Ocean as the Pacific Ocean data have been qualified by the NODC.

In the TSDC output format there is first in character 59 of the header of each station a number which indicates if this profile has been checked or not. This could be called the "version" of quality control (referring to the Quality Control Manual presented at the GTSPP meeting at OTTAWA).

- 0 means that we did not yet check this profile at the TSDC (though this profile may have been qualified elsewhere).
- 1 means that this profile has passed the first version of our quality control.

B) PROCEDURES

Version 1 of the controls consists of a screening of the profiles, compared subjectively to the LEVITUS monthly climatology at the same location. "Subjectively" means that, as there is no standard deviation in this climatology, we use an arbitrary envelope around the climatological profile, say 2 degrees wide, and some operator's "knowledge" concerning variability in the different layers, possible areas and size of temperature, inversions, etc.

While the profiles are passing this test, the flags fields are filled.

Version 2 and higher are reserved for future and higher level quality controls (consistency, models, etc ...). So there are only presently 1 or 0 in this field.

Once the profile has passed the control, the field "profile quality flag" (character 60 of the header) is filled as well as the flags attached to each of the profiles data. The fields "position flag" and "date flag" are not filled as they have not been controlled during this test.

In fact we check the positions and dates during other controls (mainly when the data base is scanned for "hard" duplicates elimination) and with ship's speed control. These tests are unfortunately not applied routinely when the data are but off line on a microcomputer. The consequence is that these flags fields are not yet filled even if position and date have been controlled. However for large errors in date or position which can be corrected (hemisphere change for instance) the flag should be 5 according to the IGOSS scale.

C) FLAGS SIGNIFICATION AND RULES

Flags attached to the data

The scale is the IGOSS scale. Of course the distinction between a doubtful (flag 3) and an erroneous (flag 4) feature is sometimes not very easy. However we have to take decisions and therefore to adopt some rules.

- spikes are flagged 4
- temperature inversions are flagged 3 for solitary profiles or for areas without referenced or known occurrence of inversions.
- Temperature increases at the bottom of the profile are flagged 4.
- When we hesitate we flag 3. Rationale: draw the attention of the user on a possible problem with this data.

For the user's life simplification we don't use flag 2 (some inconsistencies) which is **hard to interpret**. So our data are considered either as good, doubtful or wrong. Flag 2 will be used in upgraded "versions".

Profile quality flag

This flag must summarise the flags attached to the profiles data. We adopted the following rules:

- When a profile doesn't even look like a temperature profile it is rejected from the data base

- A profile flagged 4 is unusable (all the data flagged 4). Major causes: instrumental error or large uncorrectable position error.
- A profile flagged 3 contains data flagged 3 and/or 4 and may be partly usable for some purpose (the user must determine if he can or not). The most frequent case is that this profile is good down to some depth.
- A profile flagged 1 is good and contains only data flagged 1

D) COMMENTS AND RESULTS

This procedure allows the control of 400 to 800 profiles per day depending on their quality. It can be applied in an operational mode for the data collected in the TOGA area. It could not work for the WOCE area (more than one operator full time, considering that the data are collected twice).

The procedure is too dependent on the operator's constancy and knowledge. Future versions must be standardised using statistical properties.

The problem of the order of the operations is not properly solved (e.g. it is important to check and correct positions before comparing them to a climatology)

The present status of data qualification is

Years 85 and 86 completely qualified and sent to NODS/JPL for the TOGA CD ROM.

Years 87 to 89 completely qualified for delayed mode data Atlantic and Indian Oceans, partly for real time data and Pacific Ocean.

The proportion of doubtful and erroneous data per Ocean is

	Doubtful	Erroneous
Atlantic Ocean	4.7%	1 %
Indian Ocean	3.3%	2.6%
Pacific Ocean	3%	0.8%

5. CONCLUSIONS

We presented here the different controls applied to the data without major modification since the beginning of the activity of the TOGA Centre. As already mentioned in the introduction, though we are aware of the deficiencies of this system, it has not been modified because:

Basically these procedures work even if they are sometimes subjective and often cumbersome.

Any major improvement would require a fundamental modification of the structure of the data base itself.

Introducing the rules and principles based on the operator's knowledge during some operations (like the duplicate controls) to make them automatic would lead to a very complex expert system and require very large programming times.

However to process very large global data sets these procedures could not be used satisfactorily. A new system will therefore be built very soon, taking into account our own experience with the TOGA data, the recommendations of the GTSP and the requirements of the future programmes.

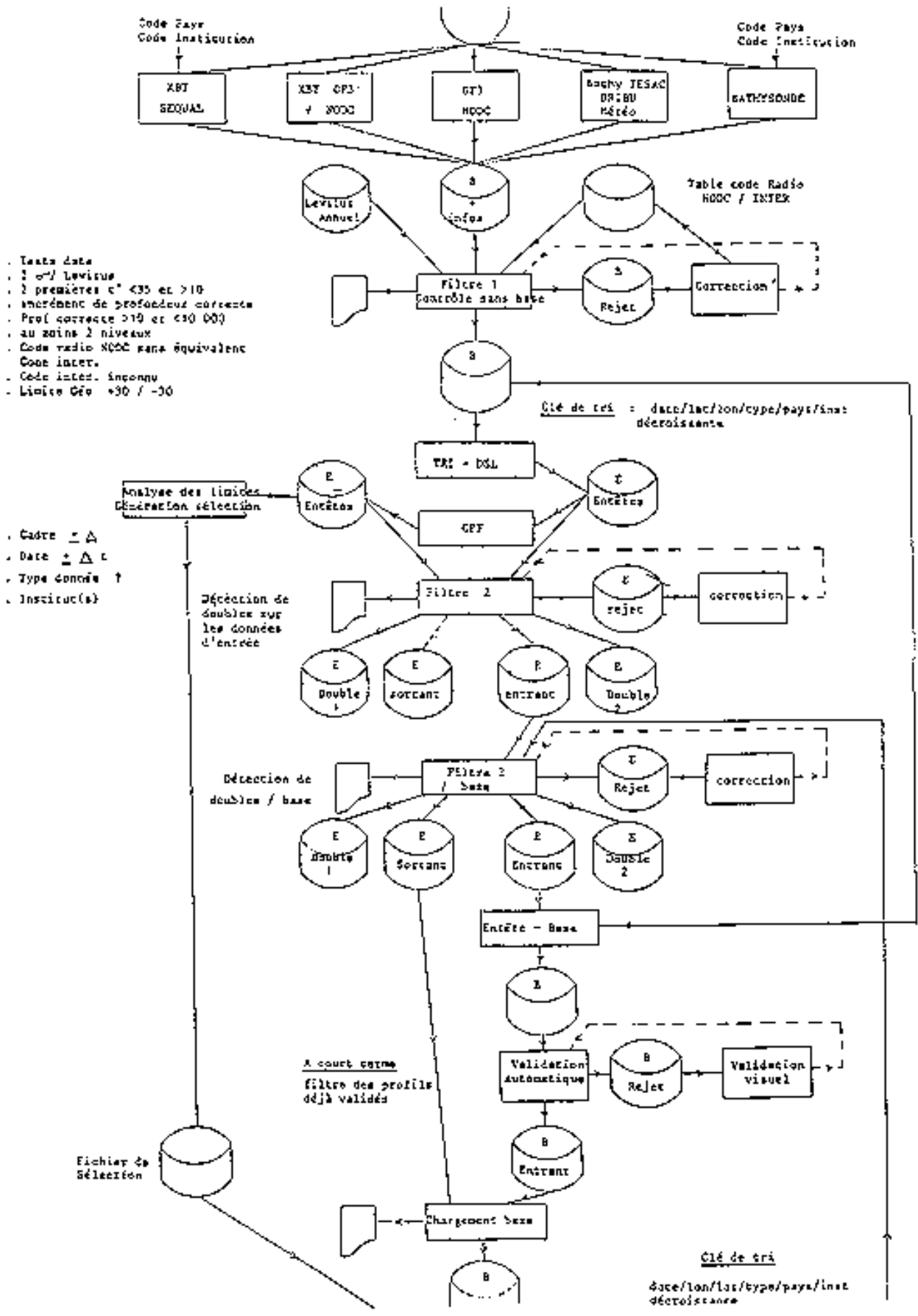

- . Tests date
- . 1 \leq Niveau
- . 2 premières \leq 435 et $>$ 10
- . incrément de profondeur correcte
- . Prof correcte $>$ 10 et \leq 100
- . au moins 2 niveaux
- . Code radio MDDC sans équivalent
- . Code inter.
- . Code inté. inconnu
- . Limite Géo \pm 30 / -30

- . Cadre \leq Δ
- . Date \leq Δ c
- . Type donnée \uparrow
- . Instituc(s)

01/13/90

TOGA SUBSURFACE DATA CENTRE

Total number of data

Year	BATHY	TESAC	XBT	CTD and Nansen	Total real- time data	Total delayed data	Total
** Ocean: Atlantic							
85	1735	63	3927	938	1798	4865	6663
86	1742	435	2963	187	2177	3150	5327
87	1017	217	3739	0	1234	3739	4973
88	995	31	3038	51	1026	3089	4115
89	2450	210	1181	0	2660	1181	3841
**Subtotal **							
	7939	956	14848	1176	8895	16024	24919
**Ocean: Indian							
85	1657	454	2435	99	2111	2534	4645
86	815	386	2325	0	1201	2325	3526
87	947	690	2798	0	1637	2798	4435
88	647	505	2494	0	1152	2494	3646
89	1978	523	759	0	2501	759	3260
**Subtotal **							
	6044	2558	10811	99	8602	10910	19512
**Ocean: Pacific							
85	2238	792	10927	66	3030	10993	14023
86	3073	778	10754	75	3851	10829	14680
87	5350	1191	11366	45	6541	11411	17952
88	4997	915	6926	89	5912	7015	12927
89	10218	711	200	58	10929	258	11187
**Subtotal **							
	25876	4387	40173	333	30263	40506	70769
***Total ***							
	39859	7901	65832	1608	47760	67440	115200

SECTION 2.7

INTERNATIONAL
HYDROGRAPHIC
ORGANIZATION



INTERGOVERNMENTAL
OCEANOGRAPHIC
COMMISSION (of UNESCO)

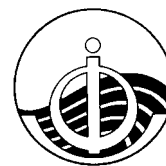

G E B C O

**GUIDELINES FOR THE
GENERAL BATHYMETRIC CHART
OF THE OCEANS**

September 1991

Published by the
INTERNATIONAL HYDROGRAPHIC BUREAU

7, avenue President J.F. Kennedy
B.P. 445 - MC 98011 MONACO Cedex
Principaute- de Monaco
Telex: 479 164 MC - INHORG
Telefax : (33) 93 25 20 03

G E B C O

GUIDELINES FOR THE GENERAL BATHYMETRIC CHART OF THE OCEANS

PLEASE NOTE ONLY PARTS OF THIS DOCUMENT HAVE BEEN REPRODUCED

Page No.
if included

PART 1	GEBCO Organizational Framework
PART 2	Bathymetric Data Management Section A Analog Data Section B Digital Data (To follow)
PART 3	Digital Bathymetric Data (Single-Beam Echo Sounders)
PART 4	Digital Bathymetric Data (Multibeam Echo Sounders) (To follow)
PART 5	Underway Geophysics Data
In addition, three Annexes are attached to the Publication, i.e.:	
ANNEX 1	Assembly Diagram for GEBCO sheets [5th Edition].
ANNEX 2	Specifications for International Bathymetric Charts (IBC) produced under IOC's regional ocean mapping projects.
ANNEX 3	Acronyms and Abbreviations

SECTION 2.7, PART 1, ANNEX A

Operational Procedure, Systems and Formats supporting the Banking of Bathymetric Data at the IHO Data Centre for Digital Bathymetry (DCDB)

The IHO DCDB operates on the basis that the prime responsibility for quality control of the data rests with the collector or custodian of the raw data. DCDB receives data from IHO Member States' Hydrographic Offices or other national Institutions or Agencies in oceanic regions on 9-track magnetic tape, by direct computer-to-computer transfer over the networks, on floppy diskette, or on specially agreed-upon transfer media. Contributors are responsible for providing digital cruise data and headers (which list general information about the cruise and data acquired during the cruise) preferably in MGD77 format. The MGD77 format is described in a separate document available from DCDB. Data provided in other formats are accepted when accompanied with concise documentation. If data are provided to DCDB in an alternate format, written headers on MGD77 coding forms are accepted.

As soon as the data package arrives, DCDB reviews the accompanying written enclosures, checks the physical condition of the data storage media and assigns the data a project number used as a permanent identifier. Documentation which should be provided as enclosures with the data by each contributor is listed in Appendix 1. If data are not provided in MGD77 format, a concise description of the format used and completed MGD77 header coding forms should be included. DCDB provides enclosure forms and header coding forms to contributors on request. If the data and headers are in MCD77 format, or if the data are in a well documented alternate format with completed MGD77 header coding forms, data processing begins. Acknowledgement via mail or electronic mail is sent to the contributor within one week of receipt of the data. If necessary the acknowledgement includes a request for any information needed by DCDB to begin processing.

Within 3 weeks of the arrival of the data to DCDB they are copied for archival protection reasons and are scanned electronically using a digital scanning routine to determine whether the format matches that described in the written documentation. A manual check of the printout of the scanning routine is completed to determine if the data are entered in the proper record fields. After this scanning review is completed, a follow-up letter or electronic mail notice is sent to the contributor explaining the results and describing the expected date of completion of assimilation. This notice will also include a request for further documentation on any received format not familiar to DCDB staff.

The first step of assimilation occurs when the data are electronically transferred to a personal computer (DCDB now uses a 386 PC) to begin error checking. Software known as "QC77" is employed to routinely check several parameters. Latitude and longitude are checked to determine whether they fall within the normal ranges of 90° to -90° and 180° and -180° respectively. Each depth value, 2-way travel time, magnetic value, and gravity value is checked against physically possible values. Any value not physically possible (see Appendix 2) is flagged by the QC77 software. Navigation is also checked by comparing the time and navigation points for accelerations and/or course changes physically possible on an oceanic vessel. If there are errors discovered in the navigation check, plots of the navigation are reviewed. If there is a discrepancy, a staff person further reviews the situation and communicates with the contributor as necessary.

There are two checks done by DCDB staff at this point in the assimilation process. First the header record is reviewed for possible data entry errors. Second, randomly selected depths of the survey are compared to GEBCO chart depths as a check for two possible errors - mismatched units of depth such as fathoms instead of meters or the misplacement of a decimal point in the depth record.

The staff at DCDB reviews any errors discovered and flagged by the QC77 software or during the two checks discussed above. If there are relatively few errors, the processing continues. But if there are a significant number of flagged errors, the contributor is notified and asked to correct and resubmit the data or provide enough information so the errors can be corrected by DCDB staff.

Next, software known as "77HI" is used to create an inventory file, which is a compacted version of each cruise. Normally the inventory file includes just enough data to define the trackline of the original cruise, usually about 2 percent of the total. The inventory file includes a list of the total number of data

records for each parameter in the data set and a complete header for each cruise. The trackline of the inventory is displayed on a computer screen, where it is reviewed for obvious errors such as ship travel across a land mass, gaps in the cruise track or unusual navigational deviations. Quality Control processing is now complete.

The final assimilation steps are data management and archival functions. All assimilated cruises are added to the master inventory which is available for IHO Member States' hydrographic offices and other appropriate Agencies as described in documentation establishing the IHO DCDB. A copy of the master data file for each cruise is archived on-site and another off-site for added security. The inventory file, which is used by DCDB as part of the data request system, is also duplicated and stored in two locations. After the data are archived, the results of the DCDB QC77 checks are offered to the contributor of the data along with a copy of the assimilated data set.

SECTION 2.7, PART 1, ANNEX A, APPENDIX 1

Documentation to be Provided with Data

ITEM	EXAMPLES
Contributor	Royal Australian Navy
Project Name	1986 Offshore Cruises
Contact	John Smith
Address	self explanatory
Telephone number	self explanatory
Facsimile number	self explanatory
Electronic mail address	(if applicable)
Digital Data Format	Internal J.O.D.C. (provide complete documentation)
Cruises Names	OFF8601, OFF8602
Storage Media	9-track tape
Density	6250 BPI
Character Code	ASCII or EBCDIC (only)
Record Size	120 bytes
Block Size	1920 bytes
Other Media Specific Information	(if applicable)
Cruise Information	MGD77 Header Coding Forms
Comments	Anything that will assist DCDB staff in the data processing.

SECTION 2.7, PART 1, ANNEX A, APPENDIX 2

Data Range limits

DATA PARAMETER	ALLOWABLE RANGE
Latitude	90° to -90°
Longitude	180° to -180°
2-way Travel Time	greater than 0 less than 15 seconds
Corrected Depth	0 to 11,000 metres
Magnetic Total Field	20,000 to 72,000 nanoteslas
Gravity	977,000 to 985,000 mgals.

SECTION 2.7, PART 3

3.1 INTRODUCTION

- 3.1.1 This chapter is concerned primarily with the storing and documenting of digital deep sea (>100m) data from single beam echosounders. It is recognised that magnetic field and gravity data are often collected simultaneously with echosounder data and there are good reasons for maintaining these data together with the sounding and navigation data. When magnetic and gravity data are also collected the contents of this chapter should be read in conjunction with Part 5 which gives guidelines for storing and documenting underway magnetic and gravity data.
- 3.1.2 The MGD77 format and the GF3 format are the preferred magnetic tape formats for the exchange of underway bathymetry (single beam), magnetic field and gravity data expressed in digital form. The guidelines presented in this chapter are compatible with these forms. The documentation standards for navigation and bathymetry are also compatible with the requirements of IHO Special Publication No. 44, Book 2 on "Classification Criteria for Deep Sea Soundings".

3.2 GUIDELINES FOR DATA ORGANISATION

- 3.2.1 It is recommended that the data should be stored on a cruise by cruise basis and that the data for each cruise should be organised in the form of a time series. A cruise is usually considered as a port-to-port operation -on occasions this may be synonymous with a cruise leg or "survey". Alternatively, the data may be grouped for convenience into surveys or survey legs. The important concept to maintain is that the grouping should relate to a specific vessel and to a specific period of time. It is recommended that the data be arranged in ascending sequence of date/time rather than as a spatial progression of positions and their associated depths. The time information provides for the possibility of valuable quality control checks and correlation with other associated data sets.
- 3.2.2 The data for each "cruise" should be stored as a single time series into which is merged navigational information and the bathymetric depths. Where available, underway measurements of the earth's magnetic and gravity fields should also be merged into the time series - the collection of these auxiliary parameters is strongly encouraged.
- 3.2.3 It is recognised that, in the initial stages of data preparation, separate time series may exist for the navigation, bathymetry, magnetics and gravity data. Indeed, the navigation data may exist with separate time series for the fixes from each navaid and a further time series of course and speed. It is essential that the navigation should be worked up into a single best fit track for the cruise such that geographic position (latitude and longitude) is directly available as a unique function of date and time - separate navigation files should not exist for the bathymetry, magnetic and gravity data (the vessel can only be in one position at a given time!!!). The final navigational time series should contain sufficient points such that when the bathymetry, magnetic, gravity etc. data time series are merged into it (with data at intervening times) the geographic position at each measurement time can be derived by simple interpolation.
- 3.2.4 In the preparation of the best fit navigation time series for the cruise and the subsequent merged data time series, it is recommended to retain and clearly identify within the series all good prime navaid fixes and turning points, irrespective of whether other measurements were collected at these times.
- 3.2.5 When other underway information is collected simultaneously with the time series data - for example seismic profiling, multibeam or swath-type echosounding etc. - the start and stop times for these data should be encoded within the time series so that automated track inventories may be maintained for these additional data types.

- 3.2.6 Whereas the time labelling of data is strongly encouraged, it is recognised that, on some surveys, shot point numbers, event marks or sonic other fiducial reference may be used in place of ship's time - in such cases the data should still be maintained in a sequential time-ordered form.
- 3.2.7 An essential part of any digital data series is the documentation describing how the data were collected and processed, the instrumentation used, the reference datum, the methods used for correcting the data, the originator's assessment of the quality of the data, the notification of instrument malfunctions or other effects influencing the quality of the data etc. It is strongly recommended that such documentation be stored in computer compatible form together with the data.

3.2 ECHOGRAM DIGITISATION

- 3.3.1 One of the weaknesses of the present day process of reporting deep sea soundings is that only a small part of the continuous sea bed profile is presented. If the data are archived on 1:1 million collected soundings sheets there is an obvious limit on the number of soundings that can be clearly displayed along the track. However, with digital storage there are no such limitations, although techniques are not yet available for storing all the information in the echosounding trace in an easily usable form.
- 3.3.2 It is recommended that, in preparing data in digital form, as much information should be extracted as to ensure that straight lines between the digitised soundings agree with the actual seabed within the tolerance established by the sounding accuracy - this implies that all peaks, deeps and points of change, of bottom slope should be digitised. Where practical considerations prohibit this level of data extraction, the original echograms or flow-film microfilm should be safely preserved in national or institutional archives.
- 3.3.3 Where data have been manually digitised it is important to check for any transcription errors that may have occurred in logging values or in keying them into computer compatible form. Particular care should be taken to avoid introducing errors at changes in the echogram recording scale. Data collected using a digitiser associated with an echosounder should also be subjected to close scrutiny.

3.4 CONTENTS OF DIGITAL DATA FILES

The preferred formats for data exchange are the MGD77 format or the GF3 format. In order to maintain compatibility with these formats, the following guidelines should be adhered to in the design of any format for the storage of underway geophysics data.

- 3.4.1 For exchange purposes the data should be stored in character format (ASCII or EBCDIC in fixed length records with fields in integer or fixed point format (or alphanumeric format for flags) in fixed positions within the record. Each record should at least contain fields compatible with the following items. (Note that the high precision to which **fields are stored is not** a reflection of expected data accuracy but is rather to maintain relative precision between adjacent readings):
- 3.4.2 Date/Time: should be expressed in UT and include year (YYYY), month (MM), day of month (DD), hours (HH) and either minutes to thousandths (MM.MMM) or minutes with seconds to hundredths (MMSS.SS).
- 3.4.3 Geographic Position: should be expressed as a latitude and a longitude either in:
- 3.4.4
- i) degrees to hundred thousandths, i.e. +/- DD.DDDDD (or +/- DDD.DDDDD) or
 - ii) degrees and minutes to ten thousandths, i.e. +/- DD +/- MM.MMMM (or +/- DDD +/- MM.MMMM)

The fields should be signed according to the convention North and East positive. For option ii) minutes and degrees should be treated as additive, i.e. both should be signed (the prime reason for signing minutes as well as degrees is to avoid ambiguities within a degree either side of the equator or the Greenwich meridian). In creating tapes for exchange, avoid minus zero (-0) as this cannot be read on some computers.

Although optional the following two items are recommended for flagging the quality of the geographic position:

3.4.3.1 Fix indicator: a single character flag field set to 'F' if the geographic position is the direct result of a good prime navaid fix ~ otherwise left blank.

3.4.3.2 Position quality: may be expressed in one of two forms:

i) using a one character flag indicating whether or not the position is considered suspect by the originator (e.g. blank = unspecified; "A" = acceptable; "S" = suspect) - supporting documentation will normally be provided to explain why positions are considered suspect; or

ii) using an error ellipse expressed in terms of its semi-major and semi-minor axes and major axis azimuth, and calculated according to a specified confidence level. For the present, this use will normally be for TRANSIT satellite fixes but, as navigation techniques develop, it may be used to assign an error ellipse to each point along the track that can then be used to determine how much each point can be shifted. The method of determination, and confidence level, of the ellipse should be described in the supporting documentation.

3.4.4 Bathymetric Depth

There are a number of different common practices for storing depth values from echosoundings depending on how the problem of correcting (or not correcting) the depth for the true speed of sound through the water column is addressed. It is strongly recommended that one, or a combination of the following standard fields should be used:

3.4.4.1 Corrected depth: expressed in metres to tenths (MMMMM.M) and standardised on the Third Edition Echo-Sounding Correction Tables (see Annex A) unless more accurate local or in situ measurements of sound velocity are available.

3.4.4.2 Uncorrected two-way travel time: expressed in seconds to 0.0001 secs (SS.SSSS).

3.4.4.3 Uncorrected depth: assuming a nominal sound velocity of 1500m/s and expressed in metres to tenths MMMMM.M) - use of a nominal sound velocity of 800 fms/s is strongly discouraged.

3.4.4.4 Whichever standard is used it is essential that the data are accompanied by a clear and unambiguous statement of the standard used, of the corrections that have been applied and of the sound speed setting of the echo sounder. It is strongly recommended that the depth is corrected for the transducer depth and, if possible, for the state of the tide (shallow water only i.e. in water depths of less than 200m).

3.4.4.5 If a valid depth value is missing, e.g. the record coincides with other measurements (magnetic field, gravity or simply a navigation fix), an appropriate null value should be entered in the depth fields. It is recommended to standardise on zero as the null value for the depth fields whatever null value is adopted should be consistently used throughout the series and clearly documented.

3.4.4.6 Bathymetry quality: a one character flag indicating whether or not the depth value is considered suspect by the originator (e.g. blank = unspecified; "A" = acceptable; "S" = suspect) - supporting documentation will normally be provided to explain why depths are considered suspect.

3.4.5 Magnetic Field Data (Optional): see 5.2

3.4.5 Gravity Data (Optional): see 5.3

3.4.7 Other Instrumentation (Optional): single character flags to indicate the availability of other underway information collected simultaneously with the time series, e.g. side scan sonar, multibeam or swath-type echosounding, seismic profiling. One flag should be assigned to each type of instrumentation so indicated. The following coding is recommended for the flag: '1' (one) - instrumentation in use; '0' (zero) - instrumentation not in use; blank - unspecified. The use of these flags provides an excellent method for generating track charts indicating the availability of other types of data, and for linking navigation information to the time base of these data.

3.5 DATA DOCUMENTATION

It is essential, when data are exchanged, that clear documentation is provided defining precisely:

- a) the format in which the data are stored and;
- b) the conditions under which the data were collected and processed (data documentation).

The data documentation should preferably be stored in computer compatible form together with the data but, if this is not possible, it may be provided in hard copy form. The forms on the following pages serve two purposes:

- a) as a ready made form for preparing hand-written documentation or,
- b) as a checklist of the items of information that should be included in computer compatible form with the data.

There are three components to the documentation viz:

- a) details about the cruise and platform;
- b) information about the navigation data and;
- c) information about the bathymetric data.

GENERAL DOCUMENTATION ABOUT THE CRUISE

INSTITUTION RESPONSIBLE FOR COLLECTING DATA:

NAME:

COUNTRY:

SHIP FROM WHICH DATA WERE COLLECTED:

SHIP NAME:

SHIP TYPE:

SHIP CALL SIGN:

LENGTH OF SHIP:

CRUISE IDENTIFIERS:

PROJECT:

CRUISE (LEG):
(OR SURVEY)

CHIEF SCIENTIST:

START DATE OF CRUISE/LEG/SURVEY - DD/MM/YY:

END DATE OF CRUISE/LEG/SURVEY - DD/MM/YY:

PORT OF DEPARTURE (name and country):

PORT OF ARRIVAL (name and country):

PURPOSE OF CRUISE AND BRIEF NARRATIVE:

.....
.....
.....
.....

SUPPORTING DOCUMENTATION FOR NAVIGATION DATA

NAVIGATION SYSTEM: systems should be clearly identified - avoid general terms such as satellite navigation or radio navigation systems - more precise information is required (e.g. Decca Hifix, LORAN C, GPS etc.)

* Prime Navaid

* Secondary Navaid:

DATUM: differences between geodetic datums, local datum and geocentric satellite navigational datum may amount to several hundred metres. It is important, therefore, that the datum should be specified when the geographic accuracy is better than 500m, either by a recognised term (e.g. "Tokyo datum", WGS84) or by quoting the reference ellipsoid constants a and 1/f and the datum translation components X₀, Y₀ and Z₀ that give the co-ordinates of the centre of the datum relative to the geocentre.

METHOD OF DETERMINING ALONG TRACK POSITIONS:

ACCURACY ASSESSMENT: estimate the geographic accuracy of 95% of the navigation fixes circling one of the following:

- <50m
- <100m
- <500m
- <2km
- <10km
- >10km

ADDITIONAL COMMENTS: include any additional information that has a bearing on the quality of the navigation, e.g. a) average number of good prime navaid fixes/day, b) identify any periods of suspect navigation (e.g. due to instrument malfunctions or lack of good fixes); c) relative position accuracy between tracks (for systematic surveys of large areas) etc.

SUPPORTING DOCUMENTATION FOR SINGLE BEAM ECHO SOUNDING DATA

NAME AND TYPE OF ECHO SOUNDER:

TOTAL BEAM WIDTH (between the -3db points):

ECHO SOUNDING SIGNAL FREQUENCY (kHz):

TIMING ACCURACY (% of travel time): circle one of the following: <0.1% <1% <2% >2%

INSTRUMENTAL SAMPLING RATE (soundings/sec): enter the instrumental sampling rate or sweep rate i.e. the rate at which the data were originally collected. NB This is not the same as the digitisation rate which, if regular, is entered under 'Sounding Selection Criteria'.

SOUNDING SELECTION CRITERIA: indicate the criteria used for extracting depth values from the echogram - such as a) peaks and troughs; b) points of change in slope; c) sea bed smooth between soundings within specified limits; d) values extracted at given time intervals - the interval should be specified; e) spot soundings etc.

.....
.....

NOMINAL SOUND VELOCITY OF ECHO SOUNDER:

PROCEDURES FOR CORRECTING FOR SOUND VELOCITY: state clearly whether the soundings were corrected for sound velocity and, if so, by which method e.g. a) in situ measures at the time of survey; b) Third Edition NP139 of the Hydrographic Department of the UK (recommended at the XIIth IHC, Monaco, 1982); c) Second Edition NP139 - Matthews Tables; d) other (please specify).

.....
.....
.....

DATUM CORRECTIONS: it is assumed that a) corrections will have been made for transducer depth (if not, then this should be clearly indicated, together with the transducer depth). Note - for towed transducers this may vary with ship speed and should be continually monitored; b) corrections will not have been made for the height of the tide unless appropriate (e.g. over seamounts or in shallow water) any corrections made should be clearly indicated, together with the tidal datum.

.....
.....
.....

ADDITIONAL COMMENTS: report on malfunctions, errors or any other factors that have a bearing on the quality of the data.

.....
.....

SECTION 2.7, PART 3, ANNEX A

THIRD EDITION ECHO-SOUNDING CORRECTION TABLES

In 1980 the Third Edition of Echo-Sounding Correction Tables was published by the Hydrographic Department of the UK to replace the tables of the Second Edition, commonly referred to as Matthews Tables, for the correction of echo-soundings for the varying speed of sound in sea water. The tables were extensively revised to incorporate the large number of temperature and salinity measurements obtained since 1939, and use an improved formula for the speed of sound in sea water derived in recent years. Computations for the revised tables were carried out by D.J.T. Carter of the Institute of Oceanographic Sciences Deacon Laboratory, Wormley, Surrey, using oceanographic station data provided by the United States National Oceanographic Data Center, Washington.

The XIIth International Hydrographic Conference at Monaco in 1982 decided to adopt the Third Edition Tables in place of Matthews Tables. The revised tables, together with a detailed description of their preparation, are contained in 'Echo-Sounding Correction Tables: Third Edition N.P. 139' published by Hydrographic Department, Ministry of Defence, Taunton, in 1980. This publication is available from Admiralty Chart Agents, whose addresses may be obtained from UK Hydrographic Office, or directly from:

The Sales Section,
Hydrographic Office,
Ministry of Defence,
Taunton, Somerset, TAI 2DN,
U.K.

The revised tables are applicable for use throughout the world in water depths of greater than 200 metres, and cover depth to the sea bed in each of 85 echo-sounding correction areas. As the boundaries between echo-sounding correction areas lie along exact degrees of latitude and longitude, the tables are particularly suited for automatic use on computerised systems. Although the published tables are listed at 10 metre intervals, values between 100 metre intervals were derived by linear interpolation, so only 100 metre values need be stored for access by a computer program.

A computerised version of the Third Edition Tables is now available, enabling echo-soundings to be corrected automatically given the ship's position. It contains copies of the two Fortran 77 sub-routines necessary to produce the corrections, together with the requisite data, i.e. the computerised echosounding correction area definitions and correction tables. The sub-routines and their data are designed for portability between different computer systems, and are obtainable on magnetic tape or floppy disk from:

- | | |
|---|--|
| i) British Oceanographic Data Centre,
Proudman Oceanographic Laboratory,
Bidston Observatory,
Birkenhead,
Merseyside. L43 7RA
U.K.
(at a charge of £50 sterling)* | or ii) World Data Center-A
(Marine Geology and Geophysics).
NOAA/E.GC3,
325 Broadway,
Boulder, Colorado 80303,
U.S.A.
(at a charge of \$100 U.S.)* |
|---|--|

* charges made to defray costs of copying the tape and postage/ packing; subject to change.

SECTION 2.7, PART 5

5.1 INTRODUCTION

This chapter contains guidelines for storing and documenting underway magnetic and gravity data collected concurrently with single beam echo-sounding data. It should be read in conjunction **with Part 3**.

5.2 STORAGE OF MAGNETIC DATA WITHIN TIME SERIES RECORDS

It is recommended that magnetic field data be expressed in terms of the following items:

- 5.2.1 Total Magnetic Field: expressed in nanoteslas to tenths (FFFFFF.F)
- 5.2.2 Residual Magnetic Field (Optional): expressed in nanoteslas to tenths (+/-RRRR.R); sometimes referred to as magnetic anomaly

$$\text{Residual field} = \text{Total field} - \text{Reference Field}$$

The reference field used should be clearly identified in the accompanying documentation.

- 5.2.3 Magnetic Field Correction (Optional): expressed in nanoteslas to tenths (+/-CCC.C) and containing the correction applied to the total magnetic field to compensate for diurnal, storm or other effects as described in the data documentation. If used, total and residual fields are assumed to have been already corrected. If set to a predefined null value (e.g. -999.9) then total and residual fields are assumed to be uncorrected.
- 5.2.4 Magnetic Field Quality: a one character flag indicating whether or not the magnetic field value is considered suspect by the originator (e.g. blank = unspecified; "A" acceptable; "S" = suspect).
- 5.2.5 It is important that the total magnetic field value should always be stored rather than be replaced by the residual magnetic field. This is to ensure that the residual field can be easily redefined should an improved reference field become available after the original processing of the data, or should a subsequent user of the data wish to standardise on another reference field.

5.3 STORAGE OF GRAVITY DATA WITHIN TIME SERIES RECORDS

It is recommended that gravity data be expressed in terms of the following items:

- 5.3.1 Observed Gravity: expressed in milligals to tenths (GGGGGG.G) and corrected for Eotvos, drift, bias and tares. The reference system (datum) should be clearly stated in the accompanying documentation, together with information on the base station and the method of tying the data into the system.
- 5.3.2 Free-air Gravity Anomaly: expressed in milligals to tenths (+/-FFF.F)

$$\text{Free-air anomaly} = \text{Observed Gravity} - \text{Theoretical Gravity}$$

The theoretical gravity formula used should be clearly identified in the accompanying documentation.

- 5.3.3 Eotvos Correction Applied to the Observed Gravity (Optional): expressed in milligals to tenths (+/-EEE.E)
- 5.3.4 Gravity Quality: a one character flag indicating whether or not the observed gravity value is considered suspect by the originator (e.g. blank = unspecified; "A" = acceptable; "S" = suspect).
- 5.3.5 Information note: Theoretical Gravity Formulae

Heiskanen 1924:	$\gamma_o = 978.052(1 + 0.005\ 285 \sin^2\varphi - 0.000\ 0070 \sin^2 2\varphi + 0.0\ 027 \cos^2\varphi \cos^2(\lambda. - 18^\circ))$
International 1930:	$\gamma_o = 978.0490(1 + 0.005\ 2884 \sin^2\varphi - 0.000\ 0059 \sin^2 2\varphi)$
IAG System 1967:	$\gamma_o = 978.03185(1 + 0.005\ 278895 \sin^2\varphi + 0.000\ 023462 \sin^4\varphi)$
IUGG (1980) Somigliani:	$\gamma_o = 978.0327(1 + 0.0053024 \sin^2\varphi - 0.000\ 0058 \sin^2 2\varphi)$

5.4 DATA DOCUMENTATION

When the time series file also includes magnetic and/or gravity data then additional data documentation should be provided along the lines indicated on the following forms.

SUPPORTING DOCUMENTATION FOR UNDERWAY MAGNETIC DATA

NAME AND TYPE OF MAC NETOMETER:
(including make and model)

INSTRUMENTAL SAMPLING INTERVAL (seconds):

DIGITISATION CRITERIA: indicate the criteria and method used for extracting field values from the original instrumental record e.g. peaks and troughs, changes of slope, fixed time intervals (specify the interval), or combinations of the foregoing etc.

.....
.....
.....

MAGNETIC SENSOR TOW DISTANCE:

MAGNETIC SENSOR DEPTH:

DESCRIPTION OF CORRECTIONS APPLIED: indicate whether, and if so how, corrections were made for diurnal variations, magnetic storms, effect of the ship's field, or other effects.

.....
.....
.....
.....

REFERENCE FIELD IDENTIFICATION: identify the Reference Field used in computing magnetic anomaly by a recognised term such as DGRF 1975, PGRF 1975, IGRF 1980 etc. - local or other fields should be clearly described.

.....
.....

ADDITIONAL COMMENTS (e.g. originator's assessment of data quality and report on any malfunctions or errors):

.....
.....
.....
.....

SUPPORTING DOCUMENTATION FOR UNDERWAY GRAVITY DATA

NAME AND TYPE OF GRAVIMETER:
(including make and model)

INSTRUMENTAL SAMPLING RATE:

DIGITISATION CRITERIA (including digitisation rate):
.....
.....

GRAVITY BASE STATION (DEPARTURE) Description of Station (including name, location and reference no.):

.....
.....

Sea level gravity at station (milligals):
(network value preferred)

GRAVITY BASE STATION (ARRIVAL): Description of Station (including name, location and reference no.):

.....
.....

Sea level gravity at station (milligals):
(network value preferred)

GRAVITY REFERENCE SYSTEM: e.g. Potsdam system, System IGN71 - local or other systems should be clearly described:

.....

THEORETICAL GRAVITY FORMULA USED: e.g. Heiskanen 1924, International 1930, IAG System 1967, IUGG (1980) Somigliani - if other then specify fully:

.....

SOURCE OF VELOCITY FOR EOTVOS CORRECTION: Indicate method used e.g. a) Differentiated navigation track; b) Direct measurement from satellite doppler; c) Other (please specify) and/or provide an estimate of accuracy of velocity used for Eotvos:

.....

DESCRIPTION OF CORRECTIONS APPLIED: describe a) method of tying data to Reference System (Datum) and b) corrections applied for drift, tare and bias. Include an estimate of errors and value of corrections applied, and assessment of data quality and a report on any equipment malfunctions:

.....
.....
.....

SECTION 2.8



GTSPP REAL-TIME QUALITY CONTROL MANUAL

GTSP REAL-TIME QUALITY CONTROL MANUAL

CONTENTS

	Page
1.0 Introduction	309
2.0 Quality Flagging	309
3.0 Instrumentation Knowledge	311
4.0 Test Monitoring	311
5.0 Pre- & Post-Processing	311
6.0 Quality Control Tests	312
7.0 Suggested Additional Tests	313
8.0 Acknowledgements	313
9.0 Bibliography	313

ANNEXES

Annex A Duplicates Management System	315
Annex B GTSP Quality Control Tests	318
Annex C Suggested Additional Tests	432

1.0 INTRODUCTION

This Manual has been produced within the context of the Global Temperature-Salinity Pilot Project (GTSP). Because the work- of assuring the quality of data handled by the Project is shared amongst data centres, it is important to have both consistent and well documented procedures. This Manual describes the means by which data quality is assessed and the actions taken as a result of the procedures.

The GTSP handles all temperature and salinity profile data. This includes observations collected using water samplers, continuous profiling instruments such as CTDs, thermistor chain data and observations acquired using thermosalinographs. These data will reach data processing centres of the Project through the real-time channels of the IGOSS program or in delayed mode through the IODE system.

The procedures described here are intended to cover only the above-mentioned data types and specifically for data sent through the IGOSS system. However, there are obvious generalizations that can be made to other data types. Because of this, it is expected that this Manual will serve as a base on which to build more extensive procedures for the aforementioned data types and to broaden to other types, as well. Indeed, in sonic cases, tests of data types that are not strictly part of this Project are incorporated into this Manual simply because they are of obvious use and because these data types are often associated with the data of interest to the GTSP.

Updates to this Manual are carried out as new procedures are recommended to the (GTSP). and as these are accepted by the project Steering Group. Readers are encouraged to make suggestions on both how to improve existing tests, and of new tests that should be considered. In both cases, it is important to explain how the suggestion improves or expands upon the existing suite of tests. Suggestions may be forwarded to any participants of the GTSP and these will be directed to the Steering Group. As tests are suggested but before incorporation, they will be documented in a section of the Manual. This will provide a means to accumulate suggestions, to disseminate them and solicit comments.

This Manual describes procedures that make extensive use of flags to indicate data quality. To make full use of this effort, participants of the (GTSP). have agreed that data access based on quality flags will be available. That is, (GTSP). participants will permit the selection of data from their archives based on quality flags as well as other criteria. These flags are always included with any data transfers that take place. Because the flags are always included, and because of the policy regarding changes to data, as described later, a user can expect the participants to disseminate data at any stage of processing. Furthermore, (GTSP). participants have agreed to retain copies of the data as originally received and to make these available to the user if requested.

The implementation of the tests in this Manual requires interactive software to be written. The operator is consulted in the setting of flags or possibly in changing data values. In each case, information is provided to the operator to help them decide what action to take. In the descriptions of the tests, certain specific items of information and data displays are included. So, for example, when a station position fails a test of platform speed, a track chart of the platform is used. The amount of information displayed and the presentation technique is dependent upon the hardware and software capabilities at the implementation site. For this reason, the information to be displayed, and the method of presentation should be treated as recommendations.

2.0 QUALITY FLAGGING

The purpose of this Manual is to set standards for quality control of real-time data and to describe exactly the screening process that is employed. By reading this document, users may assess the applicability of the procedures to their requirements and thereby judge whether they need do further work before using the data.

Attached to every profile is a number indicating the version of the Quality Control Manual which describes the tests employed. As the procedures documented by this Manual are expanded to include

others or to refine the older tests, a new version flag will be assigned. It is recognized that the suite of tests performed will undergo modifications with time. For this reason it is necessary to record which version of quality control procedures have been applied to the data. This version number is associated with updates to this Manual. The version applied is to be each profile as it is processed and to be carried thereafter with the data. This document constitutes version 1.0.

Also attached to every profile is a number that indicates which tests have been employed. This number is constructed as follows. Each test of the Quality Control Manual is assigned an index number to base 2. The number that describes the suite of tests employed against a profile is the sum of the index numbers of the tests used. The index number is given with every test documented in this Manual. This number is then written in base 16. So the digits 0 through 9 represent numbers from 0 through 9, A=10 through to F=15. As an example, if there are 10 tests, and all are employed, the Test Number is then 3FF

If a participating Data Center applies tests other than those described in this Manual, it should supply documentation with the data to explain the other tests. The use of other tests is indicated by a version number for the Manual that has a digit in the hundredths place. So, for example, a Version of 1.02 indicates that a Data Center has used the tests described in version 1.0 of the QC Manual but have also applied other tests (indicated by the digit 2) of their own. Each Data Centre may assign this last digit in a fashion suitable to their own operations.

The second type of flag is used to indicate the quality of the data. It is considered unproductive to attach a flag describing the result of each test performed to every observation since this may result in numerous flags that generally would not be used. Instead, it is deemed necessary to be able to assign flags to individual or groups of data values to indicate the confidence in the value. Participants of the GTSP have agreed that the following rules shall apply.

1. Both independent and dependent variables can have a flag assignment.
2. Data aggregations (in the case here these are entire profiles) can also be assigned a flag. So the word element used later implies aggregations as well.
3. The flags indicating data quality are those currently used in IGOSS processing with one extension.

0	= No quality control has been assigned to this element
1	= The element appears to be correct
2	= The element appears to be inconsistent with other elements
3	= The element appears doubtful
4	= The element appears erroneous
5	= The element has been changed
6 to 8	= Reserved for future use
9	= The element is missing

The general philosophy for flag assignment adopted by this Manual is that it is generally inadvisable to change data. Changes should only be instrumentation knowledge if available. It is expected that subsequent made when it is clear what the change should be and that if a change versions of the Manual will improve on this. were not made the data would be unusable.

The test descriptions allow for inferring values for those that have failed the test procedures. The inference of a correct value is done at the discretion of the person doing the quality control. It should be based on information which is not available to the test procedure but which the operator has at hand and assists in knowing what the correct value should be. Values should be changed only when there is certainty what is the correct value. In the instance where data values are changed, the original value is also preserved and is available to users or to other tests if needed.

Finally, because quality assessment is shared over processing centres, it is possible that data flagged as doubtful by one centre will be considered acceptable by another or vice versa. Flags can be changed by any processing centre as long as a record is kept of what the changes are.

The use of the flagging scheme described here will meet the stated requirements of the (GTSP). It is recognized that as new testing procedures are developed, it will be necessary to re-examine data. With version flags preserved with the data, it will be possible to identify what has been done, and therefore how best to approach the task of passing data through newer quality control procedures.

3.0 INSTRUMENTATION KNOWLEDGE

It is recognized that knowledge of the instrumentation used to make an observation can be useful in the assessment of the quality of the data. Likewise, knowledge of the platform from which the data were collected can also be used. Where available, this instrumentation knowledge should be sent with the data to the GTSP participants. The present version of this Manual suggests tests that make use of instrumentation knowledge if available. It is expected that subsequent versions of the Manual will improve on this.

4.0 TEST MONITORING

All processing centers should monitor the performance of their quality control tests. In this way, deficiencies can be identified and recommendations made to improve procedures. These recommendations should be sent to the Steering Group designated to maintain this Manual. They will be discussed and included as appropriate in subsequent versions of the Manual.

5.0 PRE AND POST PROCESSING

The quality control tests described in the appendix assume a basic scrutiny has been applied to the data. Explicitly, the data have passed a format checking procedure which ensures that alphanumerics occur where expected and no illegal characters are present. It does not assume that values of variables have been checked to see if they are physically possible.

None of the tests described here automatically assigns a quality flag without the approval of the person doing the quality assessment. When a value or element fails a test, a recommendation of the flag to be assigned is made. The person doing the quality assessment then must decide the appropriate flag to use from a list of recommendations. The tests do restrict the flags that may be assigned in that a user is not permitted to assign any flag to a value or element failing a test.

There is a need to find and remove data duplications. A check for duplicate reports is necessary to eliminate statistical biases which would arise in products incorporating the same data more than once. In searching, the distinction between exact and inexact duplicates should be kept in mind. An exact duplicate is a report in which all the physical variable groups (including space-time coordinates) are identical to those of a previous report of the same type from the same platform. An inexact duplicate will have at least one difference.

Annex A contains the algorithm proposed by the Marine Environmental Data Service for the identification of duplicates. It discusses the implementation of the technique for data received in both real-time and delayed mode. In the context of this Manual, only the discussions of the handling of realtime data is relevant. The algorithm is based on near coincidences of position, and time. This means that tests 1.1 to 1.4 and test 2.1 of this Manual must be applied before duplications are sought. The basic criteria for a possible duplication is based on the experience of the TOGA Subsurface Data Centre. So, if stations are collected within 15 minutes or 5 km of each other, they may be duplicates. The identification of the stations of potential duplicates are then examined as well as the data to resolve

whether or not a duplication exists. Then, other tests of the quality control are run on the output of the duplicates test. In this way, as little as possible is done before duplications are tested for.

There also be a need for assessment of the data- quality. This would involve subjecting the data to a different set of tests by applying knowledge of the characteristics of the processes from which observations have been collected. It may also be that more data may be gathered together so that more sophisticated statistical tests can be applied-. As such tests become generally accepted and an established application procedure developed, they could be incorporated into the context of this Manual and become part of the regular screening process conducted by participants of this project.

6.0 QUALITY CONTROL TESTS

The complete set of tests is included in Annex B. Each description has a number of sections that are always present. A description of the information that each contains follows:

Test Name: This is the short name of the test. Each test is numbered for case of reference.

Prerequisites: This describes what tests are assumed to have applied before and what preparation of the data set is suggested before application of the test. It will also describe what information files are required.

Description: This section describes how the test is implemented and what actions are taken based on the results of the test.

History: This records any changes that have taken place in the test procedure and the date on which they were recorded. This section will record the evolution of a test procedure through the various versions of the Manual.

Rules: This section lists the rules that are applied to effect the various tests. Their numbering is for reference value only since they have been written so that they may be implemented in any order.

The tests have been grouped according to stages. The first stage is concerned with determining that the position, the time, and the identification of a profile are sensible. The second stage is concerned with resolving impossible values for variables. The next stage examines the consistency of the incoming data with respect to references such as climatologies. The next section looks at the internal consistency within the data set.

The grouping of the tests suggests a logical order of implementation in that the simpler, more basic tests occur before more complicated ones. The order of presentation of tests within a stage does not imply an order in implementation. In fact, should a value be changed as a result of a test, the new value should be retested by all of the tests within the stage. Indeed, since data values can be changed, the implementation of these tests cannot take place in a strictly sequential fashion.

The tests detailed by this Manual cannot be mutually exclusive in examining the various properties and characteristics of the data. As much as possible, each test should focus on a particular property to test if the data value or profile conforms to expectations. Modifications to old tests will be incorporated as they refine the focus of the test. New tests will be added to examine properties of data that are not adequately covered by this version.

Each of the tests has been written from the point of view that the data being examined have not been before. The difference this makes is that quality flag assignments do not check if the flag has already been set to something other than 0 (meaning no quality control has been performed). If this is not the case, the rules as written will need modifications to check if the flag has previously been set. If this is the case, and a flag indicates the value was changed, the user should be informed of the original value of the data before another change is performed. Then, if the flag is reset, the changed value should be preserved in the history of the station if the flag is set to be anything else. In other cases, where a flag is

changed but the observation is untouched, it is not necessary to record the old flag, but simply to record that data have passed through a second organization and the quality tests done there.

The tests described in stage 5 represent a visual Inspection of the data as received and after all other tests have been completed. This stage is necessary to ensure that no questionable data values pass through the suite of tests employed without being detected. The testing and flagging procedure of this stage relies upon the experience and knowledge of the person conducting the test. As experience is gained with the tests contained within this Manual, the processes used in the visual inspection of stage 5 will be converted to objective tests included in other sections of the Manual. However, there will always be a need to conduct this visual inspection as the final judgement of the validity of the data.

7.0 SUGGESTED ADDITIONAL TESTS

Other tests that have been suggested are listed in Annex C. These have not yet reached the stage of being incorporated into the Manual but have been suggested as worthy of consideration. They are noted here so that participants may record their experiences with their use and so that they may be considered for future versions.

8.0 ACKNOWLEDGEMENTS

Contributions to the contents of the manual were made by J.R. Keeley, S. Levitus, D. McLain, N. Mikhailov, C. Noe, J.-P. Rebert, B. Searle, and W. White. Others have assisted in suggestions of how to improve tests and clarify the text. Information describing test procedures carried out by various organizations are noted in the Reference section. This Manual reflects the knowledge described by the references.

9.0 BIBLIOGRAPHY

1. Guidelines for evaluating and screening bathythermograph data, ICES Working Group on Marine Data Management, September, 1986.
2. Note sur les controles effectuees A Paris sur les donnees BATHY et TESAC par le centre SMISO, P. LeLay, Member of IGOSS OTA, 5 July, 1988.
3. Guide to Data Collection and Location Services Using Service Argos, Marine Meteorology and Related Oceanographic Activities Report 10, WM0/TD-No.262, 1988, Revised edition, 104pp.
4. Guide to Drifting Buoys, ICC/WMO Manuals and Guides 20,1988,69pp.
5. Ocean Temperature Fields, Northern Hemisphere Grid, 1985-1988, Office of Ocean Services, National Ocean Service, NOAA, June, 1988.
6. Ocean Temperature Fields, Southern Hemisphere Grid, 1985-1988, Office of Ocean Services, National Ocean Service, NOAA, July, 1989.
7. Guide to Operational Procedures for the Collection and Exchange of IGOSS Data, IOC/WMO Manuals and Guides 3, Revised June, 1989, 68pp.
8. Personal Communication, N. Mikhailov, 19 September, 1989.
9. Quality Improvement Profile System (QUIPS), Functional Description, R. Bauer, Compass Systems, 1987.

10. Seasonal Anomalies of Temperature and Salinity in the Northwest Atlantic in 1983, Canadian Technical Report of Hydrography and Ocean Sciences #74, March, 1988.
11. Reineger and Ross Interpolation Method, in Oceans IV: A Processing, Archiving and Retrieval System for Oceanographic Station Data, Manuscript Report Series #15, 1970, pp40-41.
12. Marine Data Platforms - An Interactive Inventory, C. Soneira, W. Woodward and C. Noe, 7pp.
13. Guidelines for Evaluating and Screening Bathythermographic Data, ICES Working Group on Data Management, September, 1986, 4pp.
14. Data Monitoring and Quality Control of Marine Observations, W.S. Richardson and P.T. Reilly.
15. IOC/IODE "Manual of Quality Control Algorithms and Procedures for Oceanographic Data Going into International Oceanographic Data Exchange", draft, 1989.
16. IOC/WMO Guide to Operational Procedures for the Collection and Exchange of IGOSS Data, Manuals & Guides #3, 68pp, 1988.
17. UNESCO Technical Papers in Marine Science #44, Algorithms for the Computation of Fundamental Properties of Seawater, UNESCO, 1983.

SECTION 2-8, ANNEX A: DUPLICATES MANAGEMENT SYSTEM

The first step is to prepare the input file for the program. This involves a prescan of the input file to identify the date/time range covered by the data to be processed through the duplicates management system and loaded into the database.

Once the prescan has identified the date/time range, a retrieval of data from all ocean vertical profile type databases for that time range is submitted. The data from the databases and the input file are sort/merged by date/time and the resulting file serves as input to the duplicates management program.

This process enables the duplicates management system to deal with duplicates in the input file, and between the input file and the databases. It provides for the identification, for example, of a CTD observation duplicating an IGOSS TESAC received earlier and will specify the de-activation of the TESAC so that requests for temperature and salinity data will not result in duplicate observations being given to the user.

Potential duplicates are reviewed with respect to a target message. The review is forward in time for a window of Δt . There is no need to go backwards as the target message would already have been reviewed with respect to a previous target.

The list of potential duplicates is established by examining each message in the Δt window with respect to the target message in terms of

- i) coincidences of platform identification, date and time; and
- ii) both observations occurring in a delta time, delta position window (15 minutes and 5 km in the initial implementation of the system).

Once the list of potential duplicates is established with respect to the target observation and all observations within the Δt window forward, more detailed analysis of the list occurs.

The first step is to attempt to remove entries from the list according to two criteria. Each observation is examined once more relative to the target. If the position is different from the position of the target by more than Δd (5 km) the observation is removed from the list. This can occur in the case of an identification/ time duplicate.

The second check examines the subsurface information for the target and each other observation on the duplicates list.

At this point it becomes necessary to consider an additional factor, the source of the observation which is carried in the databases as a variable named `STREAM_IDENT`.

The `STREAM - IDENT` identifies the observation source and a MEDS BATHY, delayed mode XBT, an observation from the scientific QC stream, etc. It is relatively easy to compare sub-surface profiles from two IGOSS BATHY messages because a duplicate observation should have the same depths and temperatures, or very nearly so. However, a comparison of a BATHY trace to a delayed mode XBT trace is not straight forward. MEDS does not yet have a sufficiently reliable algorithm for this purpose.

This means that the subsurface test can at this time only be carried out automatically on observations from the same or similar streams. Similar streams would include the delayed mode XBT and scientific QC streams as the sub-surface variables are not changed in this step.

At this time, the concept of reviewable and non-reviewable decisions by the duplicates checking program is introduced. Once the duplicates checking program has produced an output file containing all data and the database update decision, a post processor is run to permit review and alteration of "reviewable" decisions by an operator. At the post processor stage, non-reviewable decisions are accepted and are not referred to the operator.

As implied above, there are "reviewable- and "non-reviewable" decisions. The following are the tests and types of decisions (i.e. reviewable or non-reviewable) that are included in the sub-surface checking algorithm. Note that the algorithm must deal cases of different profiles attached to the two messages. This would occur for a CTD reporting salinity as well as temperature when the IGOSS message included only temperature.

1. If the observations are from non-similar streams, the profiles are assumed to be duplicates and the decision is reviewable.
2. If for all profiles, the depths and variables are the same, the profiles are assumed to be duplicates and the decision is non-reviewable.
3. If for all profiles, the depths and variables to some level involving more than n levels or X% of the maximum depth range are the same, the profiles are assumed to be duplicates and the decision is reviewable.
4. If more than 80% of depths and variables are different for all profiles the observation is assumed not to be a duplicate and is removed from the duplicates list. The decision is non-reviewable.

The goal of this strategy is to refer all grey area decisions to the operator in the post-processor phase. As the AI capabilities in MEDS improve, attempts will be made to implement software to reduce the requirements for operator review.

After completion of the final duplicates list, further processing becomes a question of making decisions on the action to be taken with each observation on the final duplicates list. These decisions are based on a prioritization of the STREAM_IDENTs occurring in the input file (which now contains the data from the database as well) stream and whether the observations come from the original input stream or the database.

The next group of decisions regarding the duplicates list is to decide the actions necessary in regard to updating the observations into the database, removing them from the database, or altering their "active status". The principles are as follows.

1. Duplicates from the same or similar input stream are not entered into the database. If such a duplicate occurs, then the decision depends on a control parameter set for the run. This control parameter specifies either "database priority" or "input stream priority". If the control parameter specifies "database priority", then the database copy and the duplicate in the input stream are marked to be "ignored" at database update which leaves the existing copy in the database. If the control parameter specifies "input stream priority" then the database copy is marked to be "deleted" from the database and the input stream copy is marked to be "updated" into the database which replaces the copy in the database with the input stream copy.

This facility provides the ability to correct data in the database by reprocessing the data and then updating it back into the database

2. If there are duplicates from two different input streams, then the observation with the highest priority in the STREAM_IDENT priority list is chosen to be the active copy. The observation(s) in the database with the lower priority will be marked to be "flagged inactive" during the update. The highest priority will be flagged to be "updated" if it is not already in the database or it will be flagged to be in the update if it is already in there and is to be left there.

Thus all observations in the input stream to the duplicates management system (including the ones that have been extracted from the databases following the prescan) are written to an output file with flags to indicate the appropriate action to be taken at update time. This output file is passed to the post processor.

The post processor is an interactive program that presents textual and graphic information to the operator in a form that allows him or her to judge whether the decision made by the duplicates management system was appropriate. If the operator disagrees with the decision, the decision can be altered at this stage relative to the observations that were on the final duplicates list. The final product of the post processor program is a data file that is ready for input to the database update system.

Note that in the MEDS implementation of the duplicates management system, there will be several separate databases including (present thinking) a BATHY database, a TESAC database, a bottle database, an MBT/XBT database, a foreign BT database, and a CTD database. The processing systems described here open and deal with all these databases during duplicates checking and update phases of the data, management system as if they were in fact one database.

SECTION 2.8, ANNEX B: GTSPQ QUALITY CONTROL TESTS

This Annex lists the tests names with their index number in parentheses after each. They are grouped by stages, and within Stage 1 they are presented in order of application. Tests in other Stages may be applied in any order, but generally, stage 2 tests should be done before stage 3 and so on.

Contents:

	Page
Stage 1: Location and Identification Tests	
1.1 Platform Identification (1)	290
1.2 Impossible Date/Time (2)	293
1.3 Impossible Location (4)	314
1.4 Position on Land (8)	318
1.5 Impossible Speed (16)	323
1.6 Impossible Sounding (32)	330
Stage 2: Profile Tests	
2.1 Global Impossible Parameter Values (64)	332
2.2 Regional Impossible Parameter Values (128)	339
2.3 Increasing Depth (256)	341
2.4 Profile Envelope (512)	344
2.5 Constant Profile (1024)	348
2.6 Freezing Point (2048)	355
2.7 Spike (4096)	359
2.8 Top and Bottom Spike (8192)	363
2.9 Gradient (16384)	369
2.10 Density Inversion (32768)	
Stage 3: Climatology Tests	
3.1 Levitus Seasonal Statistics (65536)	377
3.2 Emery and Dewar Climatology (131072)	382
3.3 Asheville Climatology (262144)389	389
3.4 Levitus Monthly Climatology (524288)	392
Stage 4: Profile Consistency Tests	
4.1 Waterfall (1048576)	396
Stage 5: Visual Inspection	
5.1 Cruise Track (2097152)	402
5.2 Profiles (4194304)	402

TEST NAME: 1.1 PLATFORM IDENTIFICATION

Prerequisites: A list of known platform identifiers Sort the file by identifier

Description:

This test is the very first to be done. It takes a data file and compares the station identifiers to a list of known identifiers. If the incoming identifier is not known, the user can either keep the station or try to infer the correct identifier.

The test starts by checking the identifier of the first station in the incoming file against a list of known identifiers to see if there is an exact match. If there is, the station is checked to determine if it is the last in the file. If it is, the test is complete. If it is not, the identifier is set to be the next in the file and this is checked against the list of known identifiers.

If the identifier was not in the list of known identifiers, the file is checked to determine if there is another identifier exactly the same in the incoming file. If so, it is added to a list of known identifiers and the identifier checked to see if it is the last in the file. If there is only one of the identifier in the file, it is assumed to be wrong.

The user can choose to infer the correct identifier. If this is not chosen, the identifier is added to the list of known identifiers. Then, the identifier is checked to see if it is the last in the file and processing continues as already described.

If the user chooses to infer the correct identifier, a corrected value may be supplied. Then a track chart is displayed of the stations in the file with the supplied identifier.

The user can then choose to accept the inferred identifier. If accepted, the identifier is changed and then checked to see if it is the last in the file and actions continue as described previously. If all choices are rejected the results from the second rule are presented and so on. If all possible inferences are rejected, the user may choose to preserve the identifier as already described.

History: None

Rules:

- 1.1.1 : Set the ID to be the first identifier in the file
: 1.1.2
- 1.1.2 IF: The identifier exists in the list of known identifiers
THEN : 1.1.3
ELSE : 1.1.5
- 1.1.3 IF: The ID is the last in the file
THEN : Next test
ELSE : 1.1.4
- 1.1.4 : Set the ID to be the next in the file
: 1.1.2
- 1.1.5 IF: There is more than one identifier in the incoming file
THEN : 1.1.6
ELSE : 1.1.7
- 1.1.6 : Notify the user that the ID was added to the list of known identifiers
: Add the ID to the list of known identifiers
: 1.1.3

- 1.1.7 IF: The user chooses to infer the correct identifier
THEN : 1.1.8
ELSE : 1.1.9
- 1.1.8 : Accept the user supplied new identifier
: Display the track chart of the new identifier;
: 1.1.9
- 1.1.9 IF: The user chooses to accept the inferred identifier
THEN : 1.1.11
ELSE : 1.1.10
- 1.1.10 IF: The user chooses to try another inference
THEN : 1.1.8
ELSE : 1.1.6
- 1.1.11 : Preserve the original identifier
: Substitute the identifier
: Set the quality flag on the identifier to be "5" changed

Test 1.1 Platform Identification

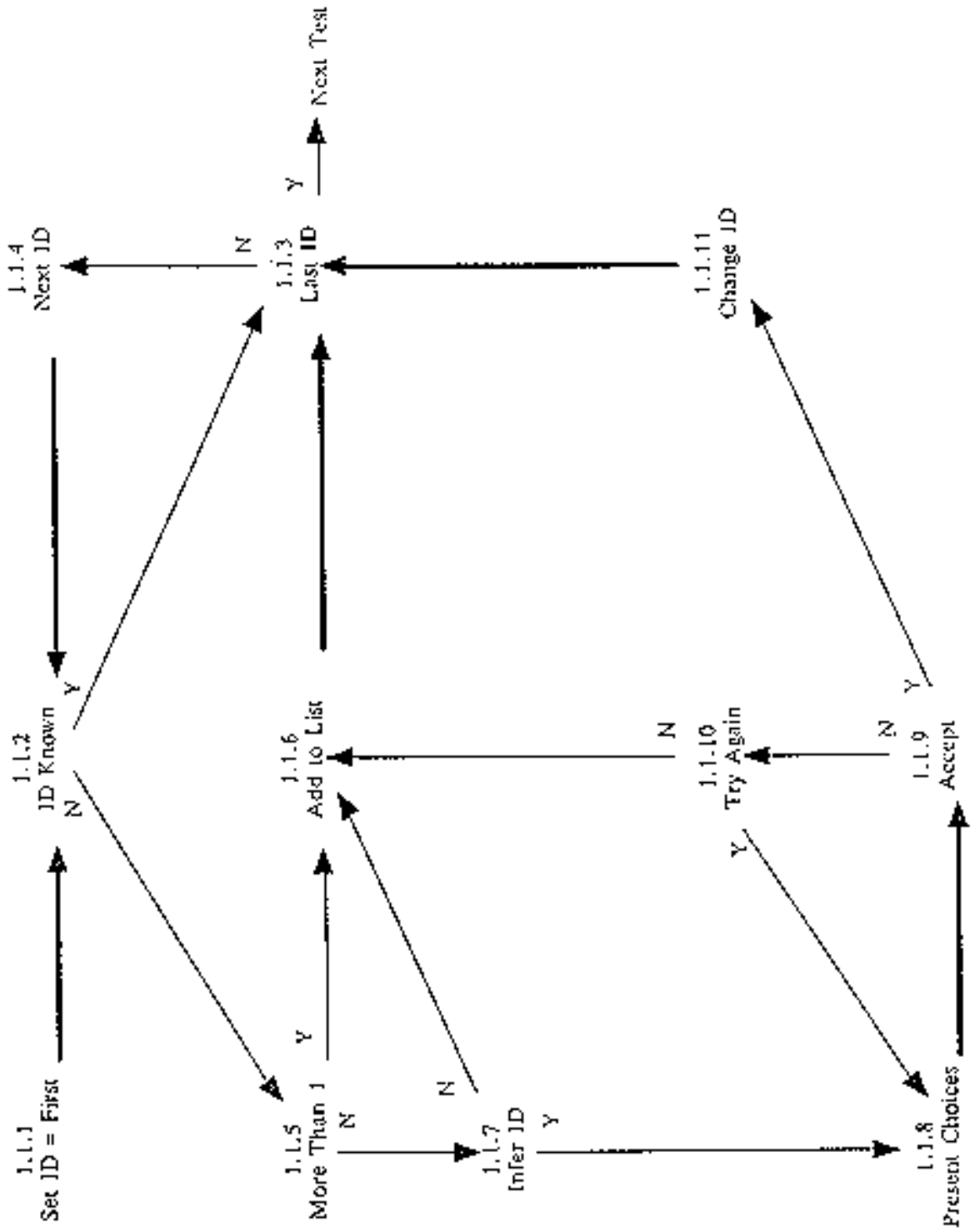

TEST NAME: 1.2 IMPOSSIBLE DATE AND TIME

Prerequisites: Platform Identification Test
Sort the file chronologically by identifier

Description:

This tests if the date and time of the observation is sensible. It does so by breaking the test into a number of parts. So, the year, month, day, hour and minutes are tested separately. Each part has a capability to infer a correct value if the given one fails the testing. The rules for the inferencing are listed in each part.

The first part tests if the year is in the past. If it is not, the user can flag the year as wrong or try to infer the correct year. The quality flag on the year is set appropriately.

The second part tests if the month is a value between 1 and 12 and if the date is not greater than the present. If any of these fail, the User can choose to flag the month, or to try to infer the correct value. The quality flag is set based on the user's choice.

The third part tests if the day is a value permitted for the given month and year, if the year or month have not already been flagged as erroneous, and if the year, month, day are not greater than the present. If any of these fail, the user can choose to flag the day, or to try to infer the correct value. The quality flag is set based on the user's choice. This test allows for real-time data by ensuring data derived from this source must have a date that is within 30 days of the present.

The fourth part tests if the hour is a value between 0 and 23 and if the time is greater than the present. If any of these fail, the user can choose to flag the hour, or to try to infer the correct value. The quality flag is set based on the user's choice.

The last part tests if the minutes are a value between 0 and 59 and if the time is greater than the present. If any of these fail, the user can choose to flag the minutes, or to try to infer the correct value. The quality flag is set based on the user's choice.

PART 1: This part begins by setting the station to be the first in the file. It then checks if the year is greater than the present year. If not, a marker is tested (this is set if a change has been made to the year as a result of an inference). If set, it is cleared, and processing passes to Part 2. If the marker was not set, the quality flag is set to be good and processing goes to Part 2. If the year is greater than the present year, it is in error. The identifier of the station is examined to see if it is unique (i.e. there is only one station with this identifier). If not unique the identifier, position, date and time of the station under consideration is displayed. As well, the same information for all of the other stations with the same identifier is also displayed. A track chart is also displayed. If the identifier is not known, the same information as described above is displayed for the station under consideration. As well, the same information for other stations in the same neighbourhood is displayed. Then the user can choose to set the quality flag on the year to be erroneous.

If the user chooses to flag the year as erroneous, the quality flag is set appropriately and testing proceeds to Part 2. If not, the user can choose to try to infer the correct year.

The identifier, position, date and time Of the station Under consideration is displayed. As well, the same information for all of the other stations inferred to he the same is also displayed. The user can choose to accept the inferred value. If so, the original value of the year is preserved, the value is changed and the quality flag set to be changed. Processing proceeds to Part 2.

If the user rejects all of the inferences, the year is flagged as erroneous and processing continues as already described.

PART 2 begins by testing if the month is a value between 1 and 12. If it is, the quality flag on the year is tested to see if it is set to be erroneous. If not set to be erroneous, the year and month are tested to

determine if they are greater than the present. If not, a marker is tested (this is set if a change has been made to the month as a result of an inference). If set, it is cleared, and processing passes to Part 3. If the marker was not set the quality flag on the month is set to be good and testing continues in Part 3. If the date is greater than the present, or if the quality flag on the year is set to be erroneous, or if the month is not between 1 and 12, then the identifier is checked.

If not unique, the identifier, position, date and time of the station under consideration is displayed. As well, the same information for all of the other stations with the same identifier is also displayed. Also a track chart is displayed. If the identifier is unique, the same information as described above is displayed for the station under consideration. As well, the same information for other stations in the same neighbourhood is displayed. Then the user can choose to set the quality flag on the month to be doubtful.

If the user chooses to flag the month as doubtful, the quality flag is set appropriately and testing proceeds to Part 3. If riot, the user can choose to set the quality flag to be erroneous. If the user chooses to flag the month as erroneous, the quality flag is set appropriately and testing proceeds to Part 3. If not, the user can choose to try to infer the correct month.

If an inference can be made the identifier, position, date and time of the station under consideration is displayed. Along with this is shown the track chart of the station. As well, the same information for all of the other stations inferred to be the same is also displayed. The user can choose to accept the inferred value. If so, and only the month is inferred to be different, the original value of the month is preserved, the value is change(-) and the quality flag set to be changed. The new value is then tested to ensure it is not greater than the present and processing proceeds as already described. If the month and year are inferred to be different, the original values are preserved, the quality flags on both are set to be changed, the marker is set and processing passes back to Part 1 to check that the year is not greater than present and processing proceeds as described before.

If an inference cannot be made the quality flag on the month is set to be erroneous and processing continues with Part 3.

PART 3 begins by testing if the day is valid given the year and month. If it is, the quality flag on the year and month are tested to see if either is set to be erroneous. If not set to be erroneous, the year, month, day is tested to determine if they are greater than the present. If not, a marker is tested (this is set if a change has been made to the day as a result of an inference). If set, it is cleared, and processing passes to Part 4. If the marker was riot set the quality flag on the day is set to be good and testing continues in Part 4. If the data did arrive in real-time, the date is checked that it is within 30 days of the present. If it is, the marker is checked as already described.

If the real-time data are older than 30 days, or if the date is greater than the present, or if the quality flag on the year or month is set to be erroneous, or if the day is riot valid then the identifier is checked.

If the identifier is riot unique, the identifier, position, date and time of the station under consideration is displayed. As well, the same information for all of the other stations with the same identifier is also displayed. Along with this is shown the track chart of the stations. If the identifier is unique, the same information as described above is displayed for the station under consideration. As well, the same information for other stations in the same neighbourhood is displayed. Then the user can choose to set the quality flag on the day to be doubtful.

If the user chooses to flag the day as doubtful, the quality flag is set appropriately and testing proceeds to Part 4. If not, the user can choose to set the quality flag to be erroneous. If the user chooses to flag the day as erroneous, the quality flag is set appropriately and testing proceeds to Part 4. If not, the user can choose to try to infer the correct day.

If an inference can be made the identifier, position, date and time of the station under consideration is displayed. Along with this is shown the track chart of the station. As well, the same information for all of the other stations inferred to be the same is also displayed. The user can choose to accept the inferred value. If so, and only the day is inferred to be different, the original value of the day is

preserved, the value is changed and the quality flag set to be changed. The new value is then tested to ensure it is not greater than the present and processing proceeds as already described. If the day and month are inferred to be different, the original values are preserved, the quality flags are set to be changed, the marker is set and processing passes back to Part 2 to check that the month and year are not greater than present and processing proceeds as described before. If the day, month and year are inferred to be different, the original values are preserved, the quality flags are set to be changed, the marker is set and processing passes back to Part 1 to check that the day, month and year are not greater than present and processing proceeds as described before.

If an inference cannot be made, the quality flag on the day is set to be erroneous and processing continues with Part 4.

PART 4 begins by testing if the hour is valid, that is between 0 and 23. If it is, the quality flag on the year, month and day are tested to see if either is set to be erroneous. If not set to be erroneous, the year, month, day and hour are tested to determine if they are greater than the present. If not, a marker is tested (this is set if a change has been made to the hour as a result of an inference). If set, it is cleared, and processing passes to Part 5. If the marker was not set the quality flag on the hour is set to be good and testing continues in Part 5.

If the date is greater than the present, or if the quality flag on the year, month or day is set to be erroneous then the identifier is checked.

If the hour was not between 0 and 23, it is tested to be the value of 24. If not, the identifier is tested. If the hour was set to 24, the hour is reset to 0, and the day incremental by one. Months and years may have to be incremented as well. Then the quality flags on the day, month and year are tested as described above.

If the identifier is not unique, the identifier, position, date and time of the station under consideration is displayed. As well, the same information for all of the other stations with the same identifier is also displayed. Along with this is shown the track chart of the station. If the identifier is unique, the same information as described above is displayed for the station under consideration. As well, the same information for other stations in the same neighbourhood is displayed. Then the user can choose to set the quality flag on the hour to be doubtful.

If the user chooses to flag the hour as doubtful, the quality flag is set appropriately and testing proceeds to Part 5. If not, the user can choose to set the quality flag to be erroneous. If the user chooses to flag the hour as erroneous, the quality flag is set appropriately and testing proceeds to Part 5. If not, the user can choose to try to infer the correct hour.

If an inference can be made, the identifier, position, date and time of the station under consideration is displayed. As well, the same information for all of the other stations inferred to be the same is also displayed. Along with this is shown the track chart of the station. The user can choose to accept the inferred value. If so, and only the hour is inferred to be different, the original value of the hour is preserved, the value is changed and the quality flag set to be changed. The new value is then tested to ensure it is not greater than the present and processing proceeds as already described. If the hour and day are inferred to be different, the original values are preserved, the quality flags are set to be changed, the marker is set and processing passes back to Part 3 to check that the day, month and year are greater than present and processing proceeds as described before. If the hour, day and month are inferred to be different, the original values are preserved, the quality flags are set to be changed, the marker is set and processing passes back to Part 2 to check that the month and year are not greater than present and processing proceeds as described before. If the hour, day, month and year are inferred to be different, the original values are preserved, the quality flags are set to be changed, the marker is set and processing passes back to Part 1 to check that the year is not greater than present and processing proceeds as described before.

If an inference cannot be, made, the quality flag on the hour is set to be erroneous and processing continues with Part 5.

PART 5 begins by testing if the minute is valid, that is between 0 and 59. If it is, the quality flag on the year, month, day and hour are tested to see if any are set to be erroneous. If not set to be erroneous, the year, month, day, hour and minute are tested to determine if they are greater than the present. If not, a marker is tested (this is set if a change has been made to the minute as a result of an inference). If set, it is cleared, and the next station is tested. If the marker was not set the quality flag on the hour is set to be good and a test is made to see if there is another station.

If the date is greater than the present, or if the quality flag on the year, month, day or minute is set to be erroneous then the identifier is checked.

If the minute was not between 0 and 59, it is tested to be the value of 60. If not, the identifier is tested. If the minute was set to 60, the minute is reset to 0, and the hour incremented by one. Days, months and years may have to be incremented as well. Then the quality flags on the hour, day, month and year are tested as described above.

If the identifier is not unique, the identifier, position, date and time of the station under consideration is displayed. As well, the same information for all of the other stations with the same identifier is also displayed. Along with this is shown the track chart of the station. If the identifier is unique, the same information as described above is displayed for the station under consideration. As well, the same information for other stations in the same neighbourhood is displayed. Then the user can choose to set the quality flag on the minute to be doubtful.

If the user chooses to flag the minute as doubtful, the quality flag is set appropriately and testing proceeds to a next station. If not, the user can choose to set the quality flag to be erroneous. If the user chooses to flag the minute as erroneous, the quality flag is set appropriately and testing proceeds to the next station. If not, the user can choose to try to infer the correct minute. At this time there are no rules for inferring the correct minute. However, the logic has been built into the rules below to permit inclusion of such rules when they are available. Since an inference, cannot be made, the quality flag is set to be erroneous and processing continues with a next station.

History: None

Rules:

Part 1:

- 1.2.1 : Set the station to be the first in the file
: 1.2.2
- 1.2.2 IF: The observed year is greater then the present year
THEN : 1.2.5
ELSE : 1.2.3
- 1.2.3 IF: MARK has been set
THEN : Clear MARK
: 1.2.18
ELSE : 1.2.4
- 1.2.4 : Set the quality flag on the year to be "I", good
: 1.2.18
- 1.2.5 IF: The platform identifier is unique
THEN : 1.2.7
ELSE : 1.2.6
- 1.2.6 : Display the ID, position and date of the ID in question
: Display the same information for any other identifiers with the same ID
: Display the track chart

- : 1.2.8
- 1.2.7 ; Display the ID, position and date of the ID in question
: Display the same information for any other identifiers in
 the neighbourhood of the ID under consideration
: 1.2.8
- 1.2.8 IF: The user chooses to flag the year as erroneous
 THEN : 1.2.9
 ELSE : 1.2.10
- 1.2.9 : Set the quality flag on the year to be "4", erroneous
: 1.2.18
- 1.2.10 IF: The user chooses to infer a value
 THEN : 1.2.12
 ELSE : 1.2.11
- 1.2.11 : Notify the user that the quality flag on the year will be set to be erroneous
: 1.2.9
- 1.2.12 : Display the ID, position and date of the ID in question
: Display the same information for the other stations with the inferred identifier
: Display the track chart
: 1.2.13
- 1.2.13 IF: The user accepts an inferred year
 THEN : 1.2.15
 ELSE : 1.2.14
- 1.2.14 IF: The user chooses to try another inference
 THEN : 1.2.10
 ELSE : 1.2.9
- 1.2.15 : Preserve the original value of the year
: Change the year to the inferred value
: Set the quality flag on the year to be '5', changed
: Set MARK
: 1.2.18

Part 2:

- 1.2.18 IF: The month is between 1 and 12
 THEN : 1.2.19
 ELSE : 1.2.23
- 1.2.19 IF: The quality flag on the year is set to be erroneous
 THEN : 1.2.23
 ELSE : 1.2.20
- 1.2.20 IF: The year and month are greater than the present
 THEN : 1.2.23
 ELSE : 1.2.21
- 1.2.21 IF: MARK is set
 THEN : Clear MARK
 : 1.2.38
 ELSE : 1.2.22

- 1.2.22 : Set the quality flag on the month to be "Y good
: 1.2.38
- 1.2.23 IF: The identifier of the station is unique
THEN : 1.2.25
ELSE : 1.2.24
- 1.2.24 : Display the ID, position and date of the ID in question
: Display the same information for any other identifiers with the same ID
: Display the track chart
: 1.2.26
- 1.2.25 : Display the ID, position and date of the ID in question
: Display the same information for any other identifiers in
the neighbourhood of the ID under consideration
: 1.2.26
- 1.2.26 IF: The user chooses to flag the month as doubtful
THEN : 1.2.27
ELSE : 1.2.28
- 1.2.27 : Set the quality flag on the month to be "Y, doubtful
: 1.2.38
- 1.2.28 IF: The user chooses to flag the month as erroneous
THEN : 1.2.29
ELSE : 1.2.30
- 1.2.29 : Set the quality flag on the month to be 'A', erroneous
: 1.2.28
- 1.2.30 IF: An inference can be made of the correct month
THEN : 1.2.32
ELSE : 1.2.31
- 1.2.31 : Notify the user that no inferences can be made
: Notify the user that the quality flag on the month will be set to be erroneous
: 1.2.29
- 1.2.32 : Display the ID, position and date of the ID in question
: Display the same information for the other stations with the inferred identifier
: Display the track chart
: 1.2.33
- 1.2.33 IF: The user accepts the inferred month
THEN : 1.2.35
ELSE : 1.2.34
- 1.2.34 IF: The user chooses to try another inference
THEN : 1.2.30
ELSE : Notify the user that the month will be flagged as erroneous
: 1.2.29
- 1.2.35 IF: Only the month should be changed
THEN : 1.2.36
ELSE : 1.2.37

1.2.36 : Preserve the original value Of the month
: Change the month to the inferred value
: Set the quality flag on the month to be "5", changed
: Set MARK
: 1.2.20

1.2.37 : Preserve the original value of the month
: Change the month to the inferred value
: Set the quality flag on the month to be "5", changed
: Preserve the original value of the year
: Change the year to the inferred value
: Set the quality flag on the year to be '5', changed
: Set MARK
: 1.2.2

Part 3:

1.2.38 IF: The day is possible for the given month and year
THEN : 1.2.39
ELSE : 1.2.45

1.2.39 IF: Either the quality flag on the month or year is set to be erroneous
THEN : 1.2.45
ELSE ; 1.2.40

1.2.40 IF: The year, month, day is greater than the present
THEN : 1.2.44
ELSE : 1.2.42

1.2.41 IF: MARK is set
THEN : Clear MARK
: 1.2.62
ELSE : 1.2.43

1.2.42 IF: The year, month, day is older than 30 days from the present
THEN : 1.2.44
ELSE : 1.2.41

1.2.43 : Set the quality flag on the day to be good
: 1.2.62

1.2.44 IF: The identifier of the station is not unique
THEN : 1.2.45
ELSE : 1.2.46

1.2.45 : Display the ID, position and date of the ID in question
: Display the same information for any other identifiers in
the neighbourhood of the ID under consideration
: Display the track chart
: 1.2.47

1.2.46 : Display the ID, position and date of the ID in question
: Display the same information for any other identifiers with the same ID
: 1.2.47

1.2.47 IF: The user chooses to flag the day as doubtful
THEN : 1.2.48
ELSE : 1.2.49

- 1.2.48 : Set the quality flag on the day to be "Y, doubtful
: 1.2.62
- 1.2.49 IF: The user chooses to flag the day as erroneous
THEN : 1.2.50
ELSE : 1.2.51
- 1.2.50 : Set the quality flag on the day to be "4", erroneous
: 1.2.62
- 1.2.51 IF: An inference can be made of the correct day
THEN : 1.2.53
ELSE : 1.2.52
- 1.2.52 : Notify the user that the quality flag on the day will be set to be erroneous
: 1.2.50
- 1.2.53 ; Display the ID, position and date of the ID in question
: Display the same information for the other stations with the inferred identifier
: Display the track chart
: 1.2.54
- 1.2.54 IF: The user accepts the inferred day
THEN : 1.2.56
ELSE : 1.2.55
- 1.2.55 IF: The user chooses to try another inference
THEN : 1.2.51
ELSE : Notify the user that the day will be flagged as erroneous
: 1.2.50
- 1.2.56 IF: Only the day should be changed
THEN : 1.2.57
ELSE : 1.2.58
- 1.2.57 : Preserve the original value of the day
: Change the day to the inferred value
: Set the quality flag on the day to be "5", changed
: Set MARK
: 1.2.40
- 1.2.58 IF: Only the day and month should be changed
THEN : 1.2.59
ELSE : 1.2.60
- 1.2.59 : Preserve the original value of the day
: Change the day to the inferred value
: Set the quality flag on the day to be "5", changed
: Preserve the original value of the month
: Change the month to the inferred value
: Set the quality flag on the month to be '5', changed
: Set MARK
: 1.2.20
- 1.2.60 : Preserve the original value of the day
: Change the day to the inferred value
: Set the quality flag on the day to be "S", changed

: Preserve the original value of the month
: Change the month to the inferred value
: Set the quality flag on the month to be "5", changed
: Preserve the original value of the year
: Change the year to the inferred value
: Set the quality flag on the year to be "5", changed
: Set MARK
: 1.2.2

Part 4:

- 1.2.62 IF: The hour is a number between 0 and 23 inclusive
THEN : 1.2.63
ELSE : 1.2.67
- 1.2.63 IF: Any of the year, month or day have a quality flag set to be erroneous
THEN : 1.2.69
ELSE : 1.2.64
- 1.2.64 IF: The year, Month, day, hour is greater than the present
THEN : 1.2.69
ELSE : 1.2.65
- 1.2.65 IF: The marker is set
THEN : 1.2.88
ELSE : 1.2.66
- 1.2.66 : Set the quality flag on the hour to be 1 good
: 1.2.88
- 1.2.67 IF: The hour is equal to 24
THEN : 1.2.68
ELSE : 1.2.69
- 1.2.68 : Preserve the original value of the hour
: Set the hour to be 0
: Set the quality flag on the hour to be "5", changed
: Preserve the original value of the clay
: Set the day to be 1 greater than the original value
: Set the quality flag on the day to be "5", changed
: 1.2.63
- 1.2.69 IF: The identifier of the station is not unique
THEN : 1.2.70
ELSE : 1.2.71
- 1.2.70 : Display the ID, position and date of the ID in question
: Display the same information for any other identifiers with the same ID
: Display the track chart
: 1.2.72
- 1.2.71 : Display the ID, position and date of the ID in question
: Display the same information for any other identifiers in
the neighbourhood of the ID under consideration
: 1.2.72
- 1.2.72 IF: The user chooses to flag the hour as doubtful
THEN : 1.2.73

- ELSE : 1.2.74
- 1.2.73 : Set the quality flag on the hour to be "Y, doubtful
: 1.2.88
- 1.2.74 IF: The user chooses to flag the hour as erroneous
THEN : 1.2.75
ELSE : 1.2.76
- 1.2.75 : Set the quality flag on the hour to be "4", erroneous
: 1.2.88
- 1.2.76 IF: An inference can be made of the correct hour
THEN : 1.2.77
ELSE : 1.2.78
- 1.2.77 : Display the ID, position and date of the ID in question
: Display the same information for the other stations with the inferred identifier
: 1.2.78
- 1.2.78 IF: The user accepts the inferred hour
THEN : 1.2.80
ELSE : 1.2.79
- 1.2.79 IF: The user chooses to try another inference
THEN : 1.2.76
ELSE : Notify the user that the hour will be flagged as erroneous
1.2.75
- 1.2.80 IF: Only the hour should be changed
THEN : 1.2.81
ELSE : 1.2.82
- 1.2.81 : Preserve the original value of the hour
: Change the hour to the inferred value
: Set the quality flag on the hour to be "5", changed
: Set MARK
: 1.2.64
- 1.2.82 IF: Only the hour and day should be changed
THEN : 1.2.83
ELSE : 1.2.84
- 1.2.83 : Preserve the original value of the hour
: Change the hour to the inferred value
: Set the quality flag on the hour to be "5", changed
: Preserve the original value of the day
: Change the day to the inferred value
: Set the quality flag on the day to be '5', changed
: Set MARK
: 1.2.40
- 1.2.84 IF: Only the hour, clay and month should be changed
THEN : 1.2.85
ELSE : 1.2.86
- 1.2.85 : Preserve the original value of the hour
: Change the hour to the inferred value

: Set the quality flag on the hour to be "5", changed
: Preserve the original value of the day
: Change the day to the inferred Value
: Set the quality flag on the day to be "5", changed
: Preserve the original value of the month
: Change the month to the inferred value
: Set the quality flag on the month to be "5", changed
: Set MARK
: 1.2.20

1.2.86 : Preserve the original value of the, hour
: Change the hour to the inferred value
: Set the quality flag on the hour to be "5", changed
: Preserve the original value of the day
: Change the day to the inferred value
: Set the quality flag on the day to be "5", changed
: Preserve the original value of the month
: Change the month to the inferred value
: Set the quality flag on the month to be "5", changed
: Preserve the original value of the year
: Change the year to the inferred value
: Set the quality flag on the year to be "5", changed
: Set MARK
: 1.2.2

Part 5:

1.2.88 IF: The minute is a value between 0 and 59
THEN : 1.2.89
ELSE : 1.2.93

1.2.89 IF: Any of the quality flags on the hour, day, month or year is set to be erroneous
THEN : 1.2.95
ELSE : 1.2.90

1.2.90 IF: The year, month, day, hour, minute is greater than the present
THEN : 1.2.95
ELSE : 1.2.91

1.2.91 IF: The marker is set
THEN : Test the next station
ELSE : 1.2.92

1.2.92 : Set the quality flag on the minute to be "1" good
: Test the next station

1.2.93 IF: The minute is equal to 60
THEN : 1.2.94
ELSE : 1.2.95

1.2.94 : Set the minute to be 00
: Increment the hour by 1
: Increment the day, month and year as appropriate
: 1.2.2

1.2.95 IF: The identifier of the station is unique
THEN : 1.2.97
ELSE : 1.2.96

- 1.2.96 : Display the ID, position and date of the, ID in question
: Display the same information for any other identifiers in
the neighbourhood of the ID under consideration
: 1.2.98
- 1.2.97 : Display the ID, position and date of the ID in question
: Display the same information for any other identifiers with the same ID
: Display the track chart
: 1.2.98
- 1.2.98 IF : The user chooses to flag the minute as doubtful
THEN : 1.2.99
ELSE : 1.2.100
- 1.2.99 : Set the quality flag on the minute to be "Y, doubtful
: Test the next station
- 1.2.100 IF : The user chooses to flag the minute as erroneous
THEN : 1.2.101
ELSE : 1.2.102
- 1.2.101 :Set the quality flag on the minute to be "4", erroneous
:Test the next station
- 1.2.102 IF: An inference can be made of the correct minute
THEN : 1.2.103
ELSE : 1.2.101
- 1.2.103 : Display the ID, position and date of the ID in question
: Display the same information for the other stations with the inferred identifier
: Display the track chart
: 1.2.104
- 1.2.104 IF: The user accepts the inferred minute
THEN : 1.2.106
ELSE : 1.2.105
- 1.2.105 : Notify the user that the minute will be flagged as erroneous
: 1.2.101
- 1.2.106 IF: Only the minute should be changed
THEN : 1.2.107
ELSE : 1.2.108
- 1.2.107 : Preserve the original value of the minute
: Change the minute to the inferred value
: Set the quality flag on the minute to be "5", changed
: Set MARK
: 1.2.90
- 1.2.108 IF: Only the minute and hour should be changed
THEN : 1.2.109
ELSE : 1.2.110
- 1.2.109 : Preserve the original value of the minute
: Change the minute to the inferred value
: Set the quality flag on the minute to be "5", changed

- : Preserve the original value of the hour
 - : Change the hour to the inferred value
 - : Set the quality flag on the hour to be "5", changed
 - : Set MARK
 - : 1.2.64
1. 2, 110 IF: Only the minute, hour and day should be changed
THEN : 1.2.111
ELSE : 1.2.112
- 1.2.111 :
: Preserve the original value of the minute
: Change the minute to the inferred value
: Set the quality flag on the minute to be "5", changed
: Preserve the original value of the hour
: Change the hour to the inferred value
: Set the quality flag on the hour to be "5", changed
: Preserve the original value of the day
: Change the day to the inferred value
: Set the quality flag on the day to be "5", changed
: Set MARK
: 1.2.40
- 1.2.112 IF: Only the minute, hour, day and month should be changed
THEN : 1.2.113
ELSE :1.2.114
- 1.2.113 :
: Preserve the original value of the minute
: Change the minute to the inferred value
Set the quality flag on the minute to be "5", changed
: Preserve the original value of the hour
: Change the hour to the inferred value
: Set the quality flag on the hour to be "5", changed
: Preserve the original value of the day
: Change the day to the inferred value
: Set the quality flag on the day to be "5", changed
: Preserve the original value of the month
: Change the month to the inferred value
: Set the quality flag on the month to be '5', changed
: Set MARK
: 1.2.20
- 1.2.114 :
: Preserve the original value of the minute Change the minute to the inferred value
: Set the quality flag on the minute to be "5", changed
: Preserve the original value of the hour Change the hour to the inferred value
: Set the quality flag on the hour to be "5", changed
: Preserve the original value of the day Change the day to the inferred value
: Set the quality flag on the day to be "5", changed
: Preserve the original value of the month Change the month to the inferred value
: Set the quality flag on the month to be "5", changed
: Preserve the original value of the year Change the year to the inferred value
: Set the quality flag on the year to be "5", changed
: Set MARK
: 1.2.2

1.2 Impossible Date and Time
Part I: Impossible Year

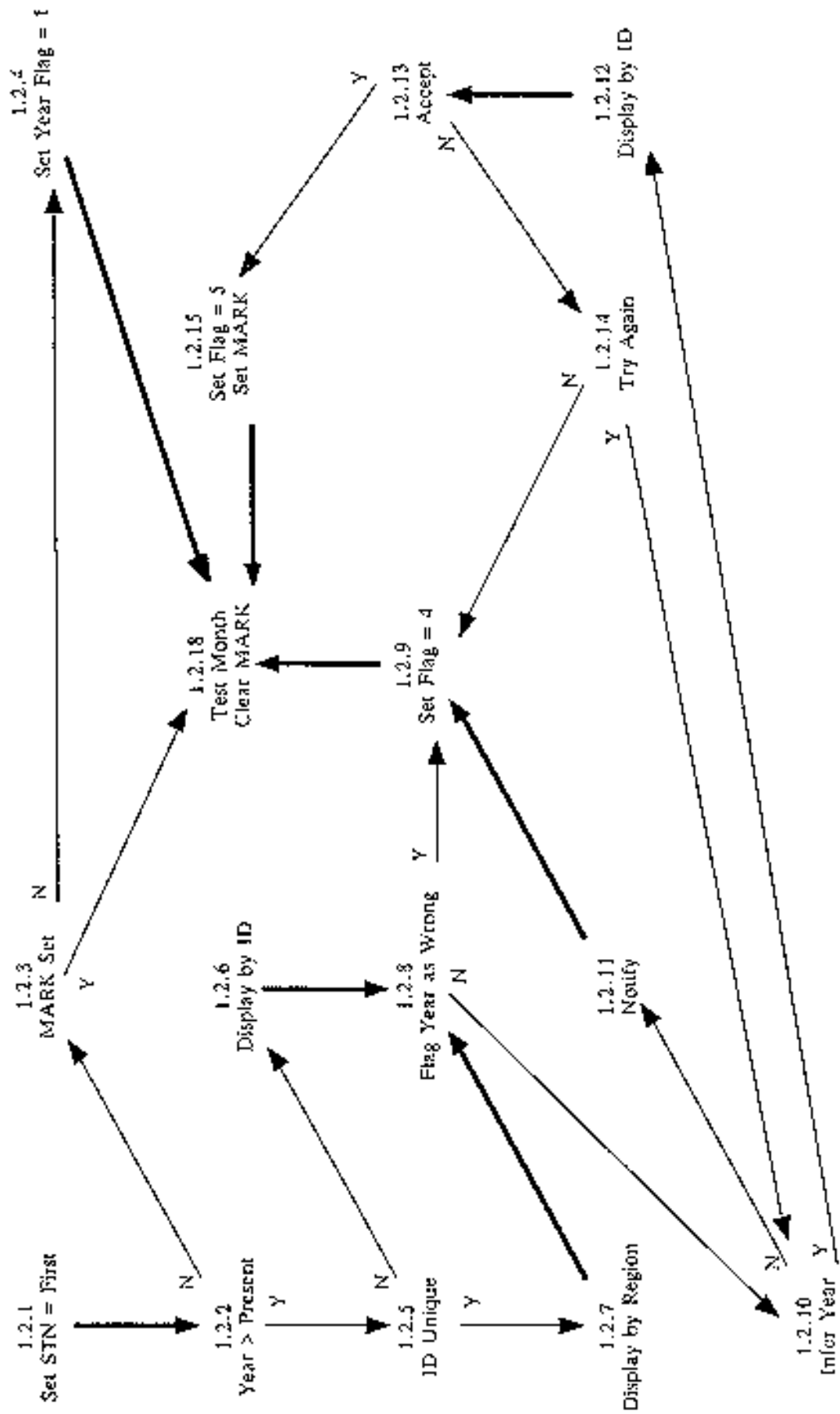

1.2 Impossible Date and Time
Part 2: Impossible Month

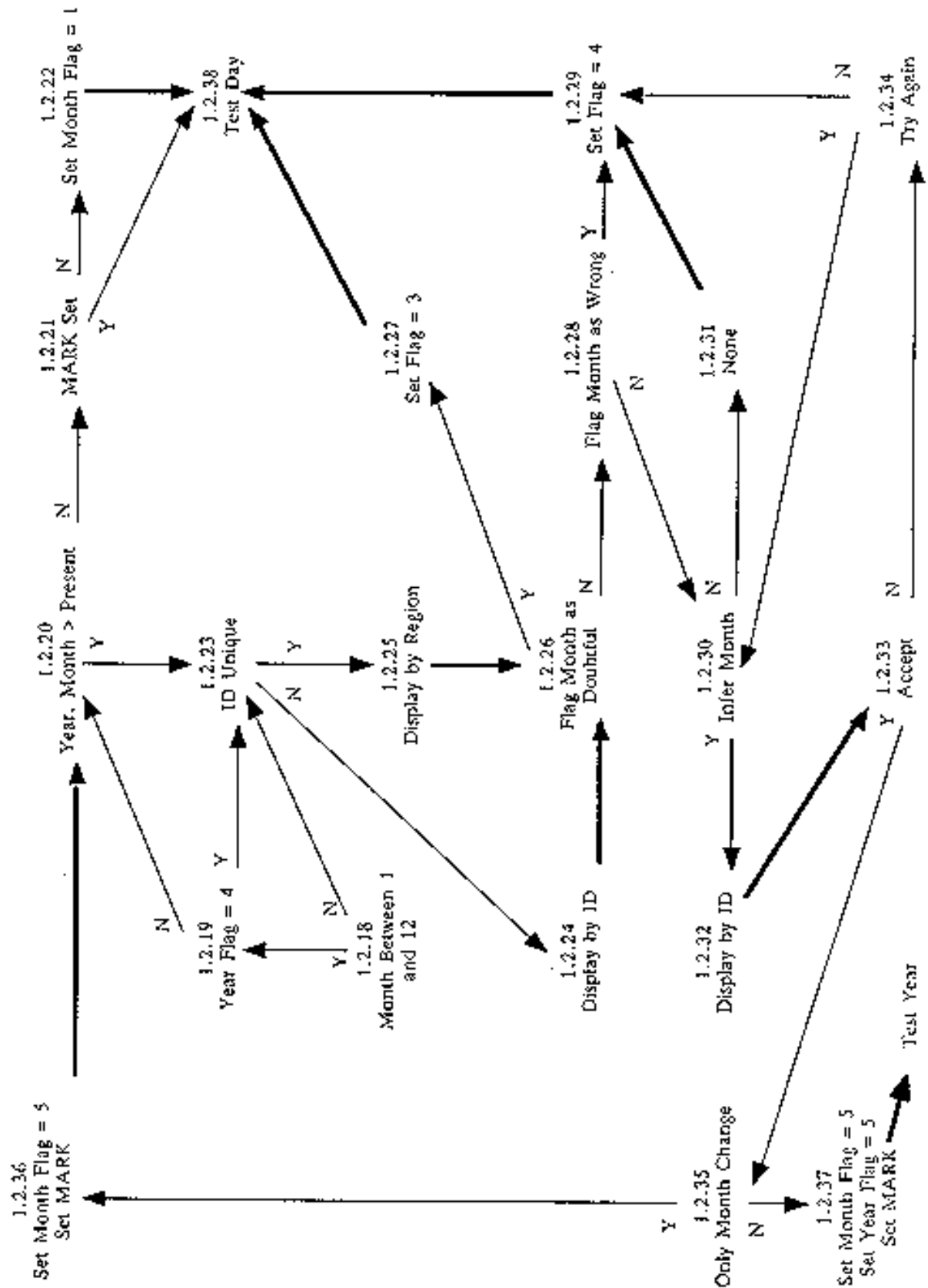

**1.2 Impossible Date and Time
Part 3: Impossible Day**

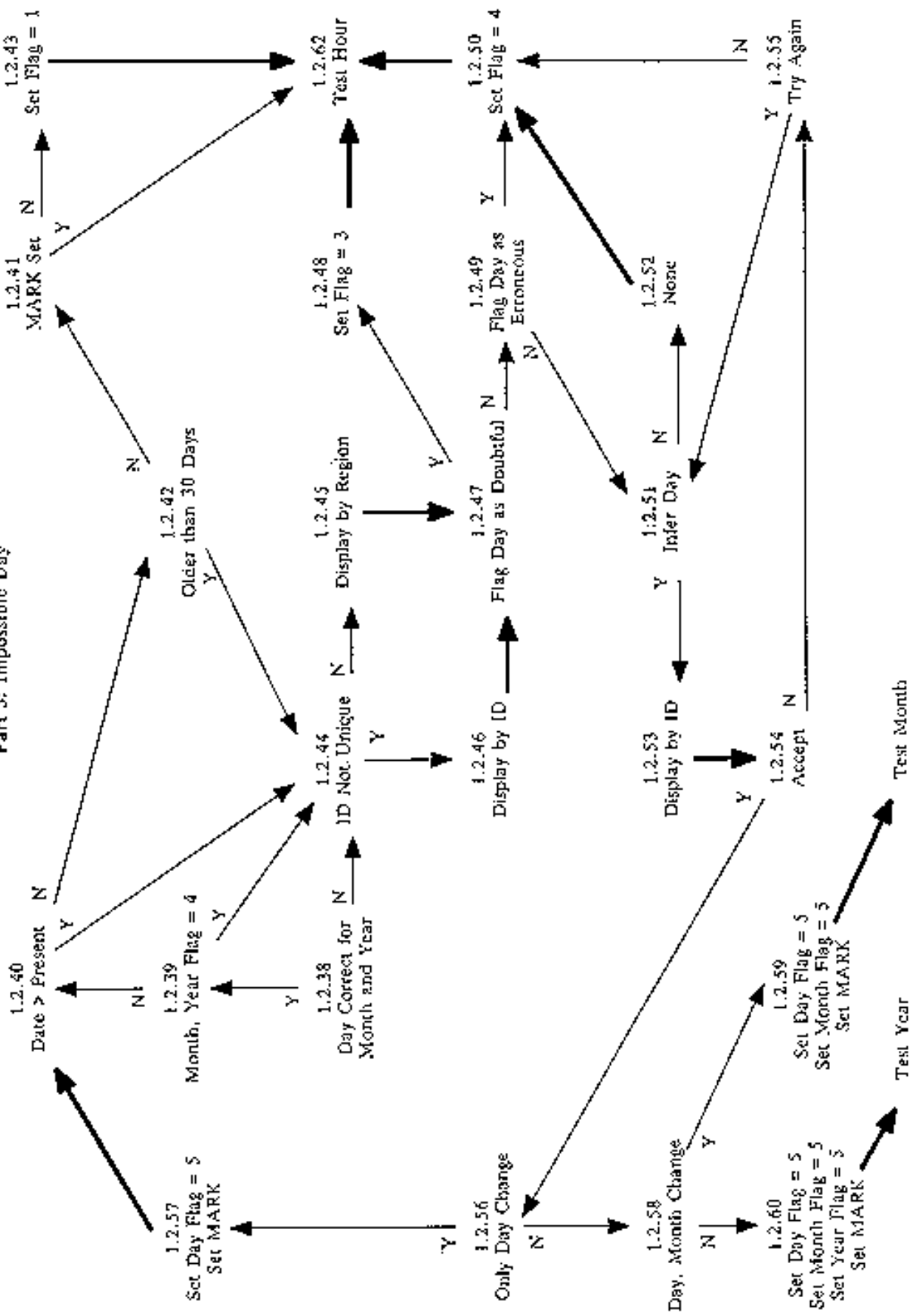

1.2 Impossible Date and Time
 Part 4A: Impossible Hour

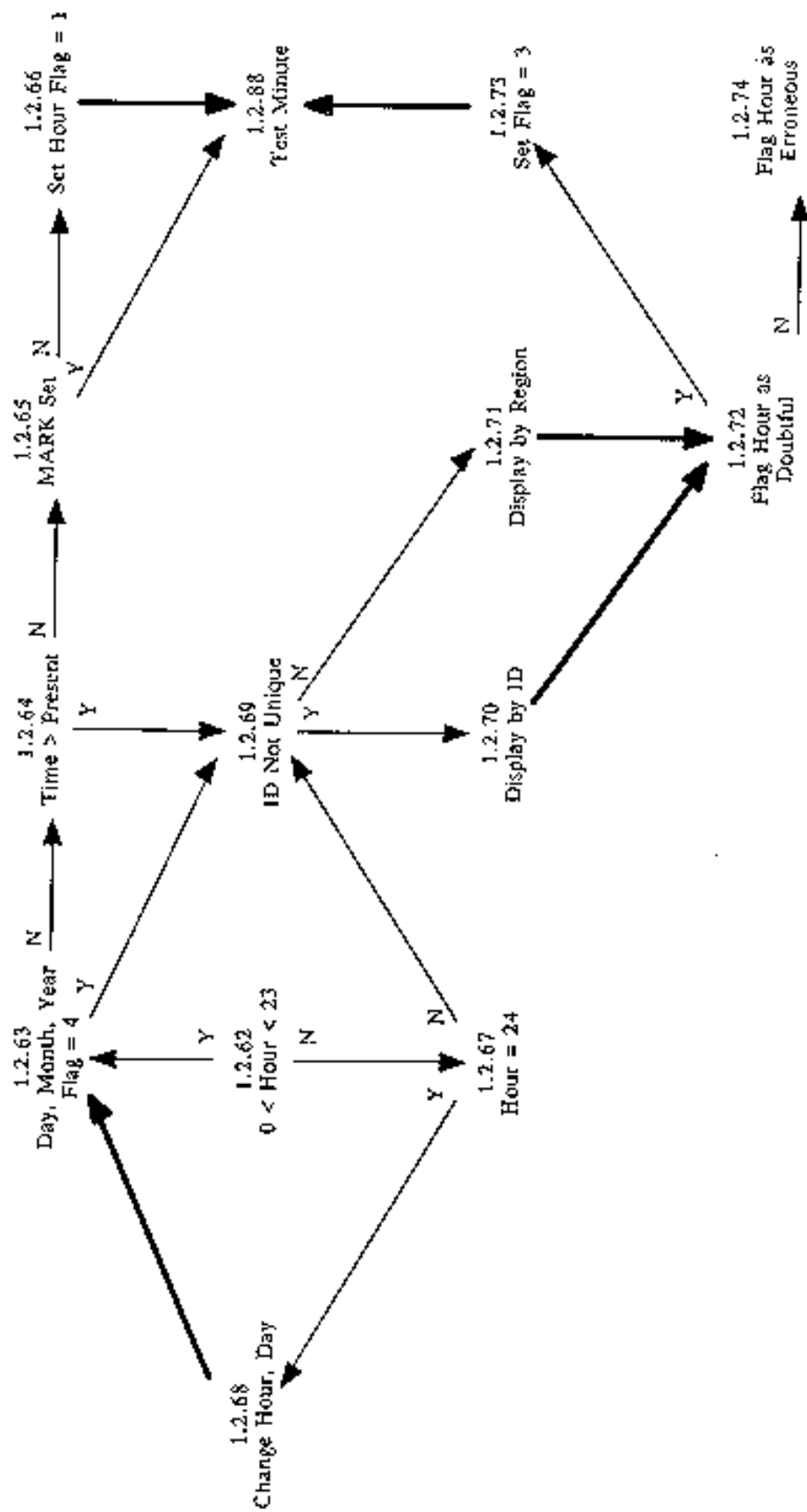

1.2 Impossible Date and Time
Part 4B: Impossible Hour

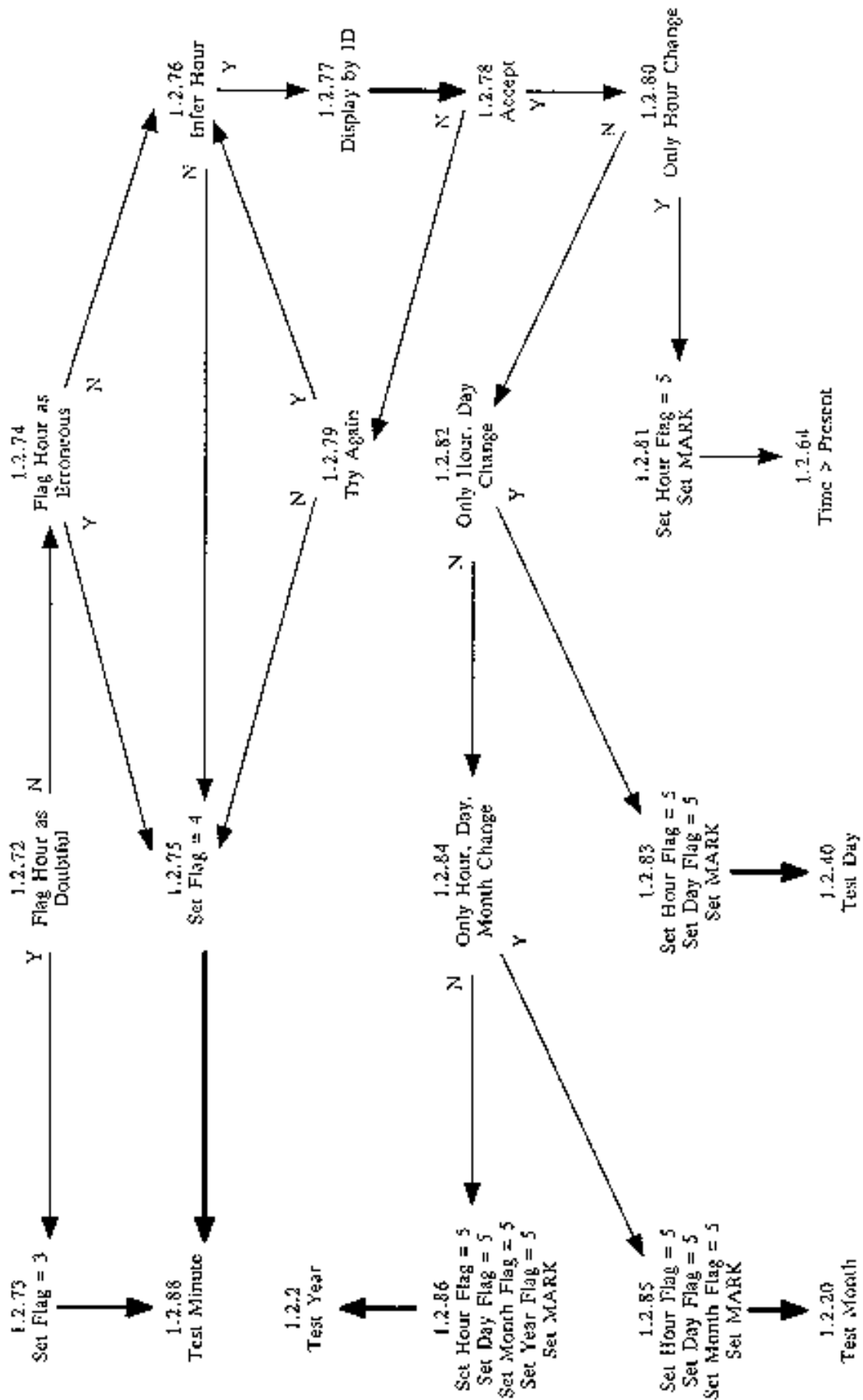

1.2 Impossible Date and Time
Part 5A: Impossible Minute

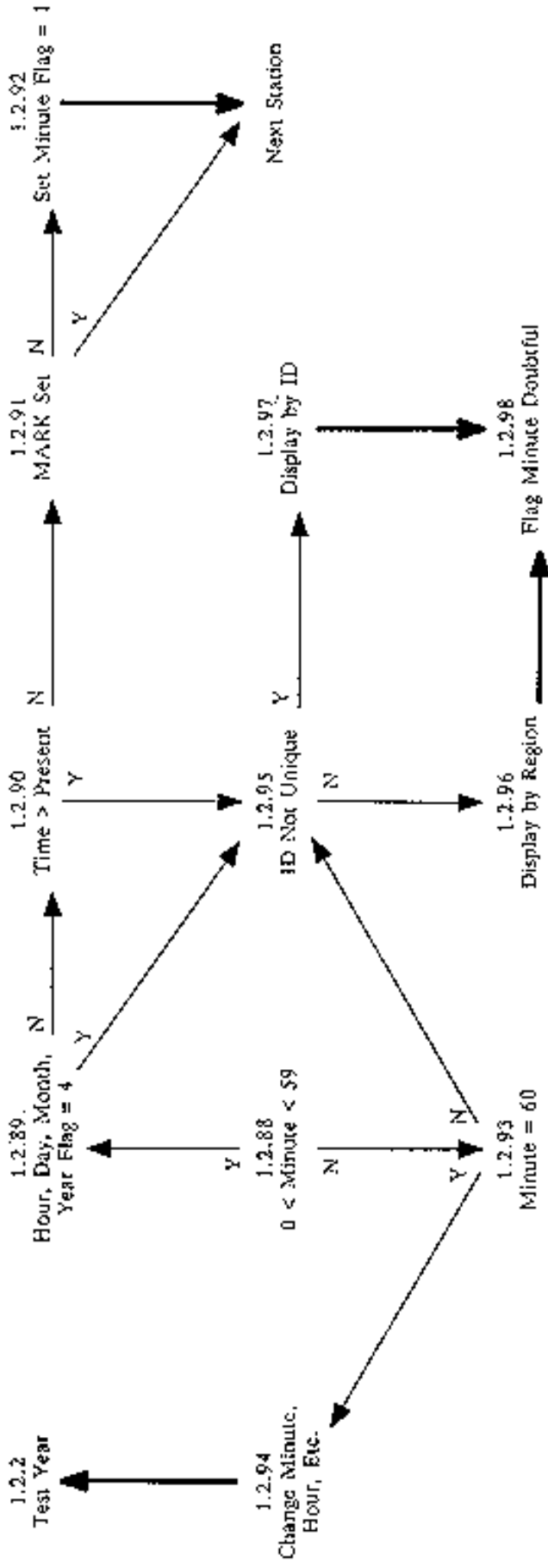

1.2 Impossible Date and Time
Part 5B: Impossible Minute

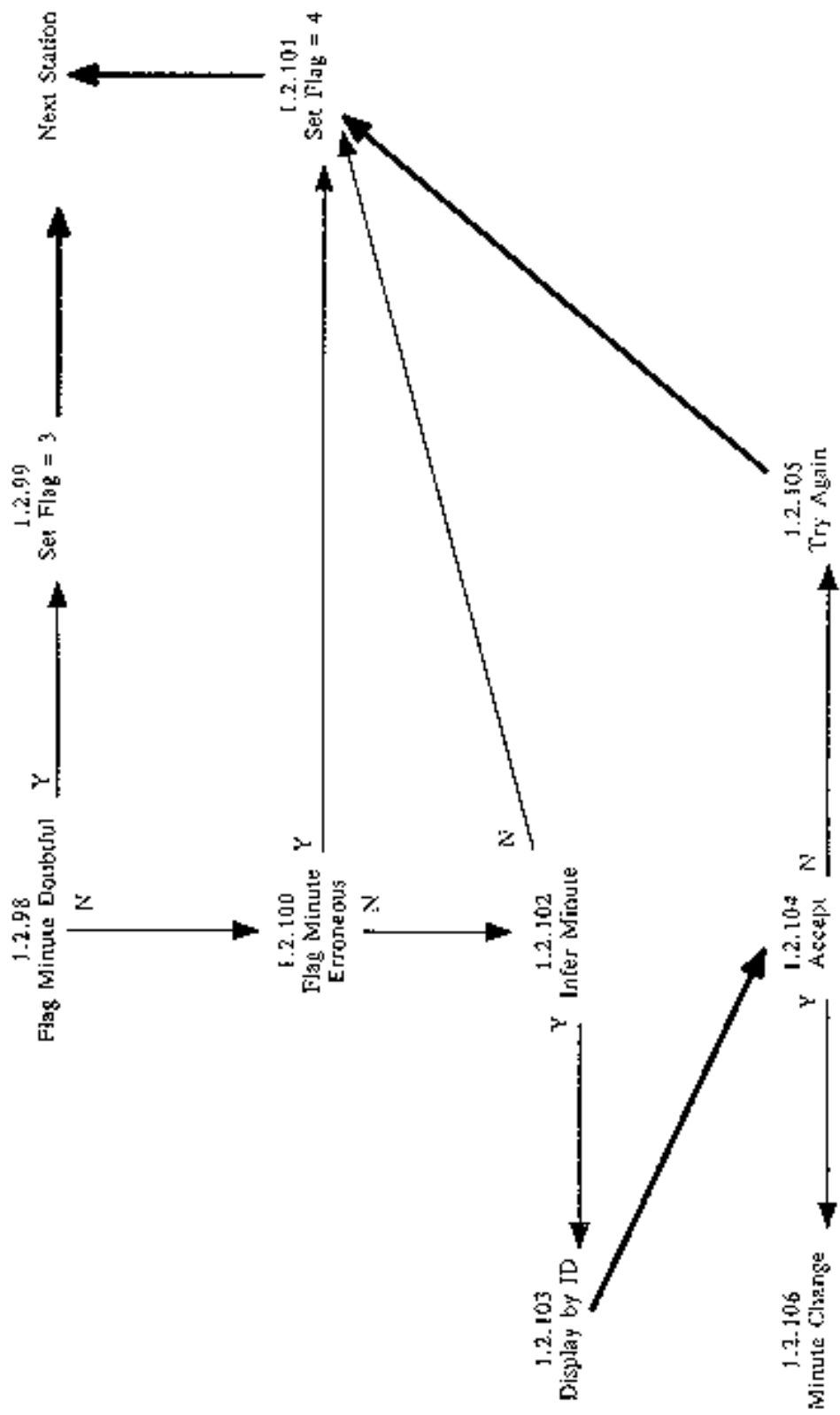

1.2 Impossible Date and Time
 Part 5C: Impossible Minute

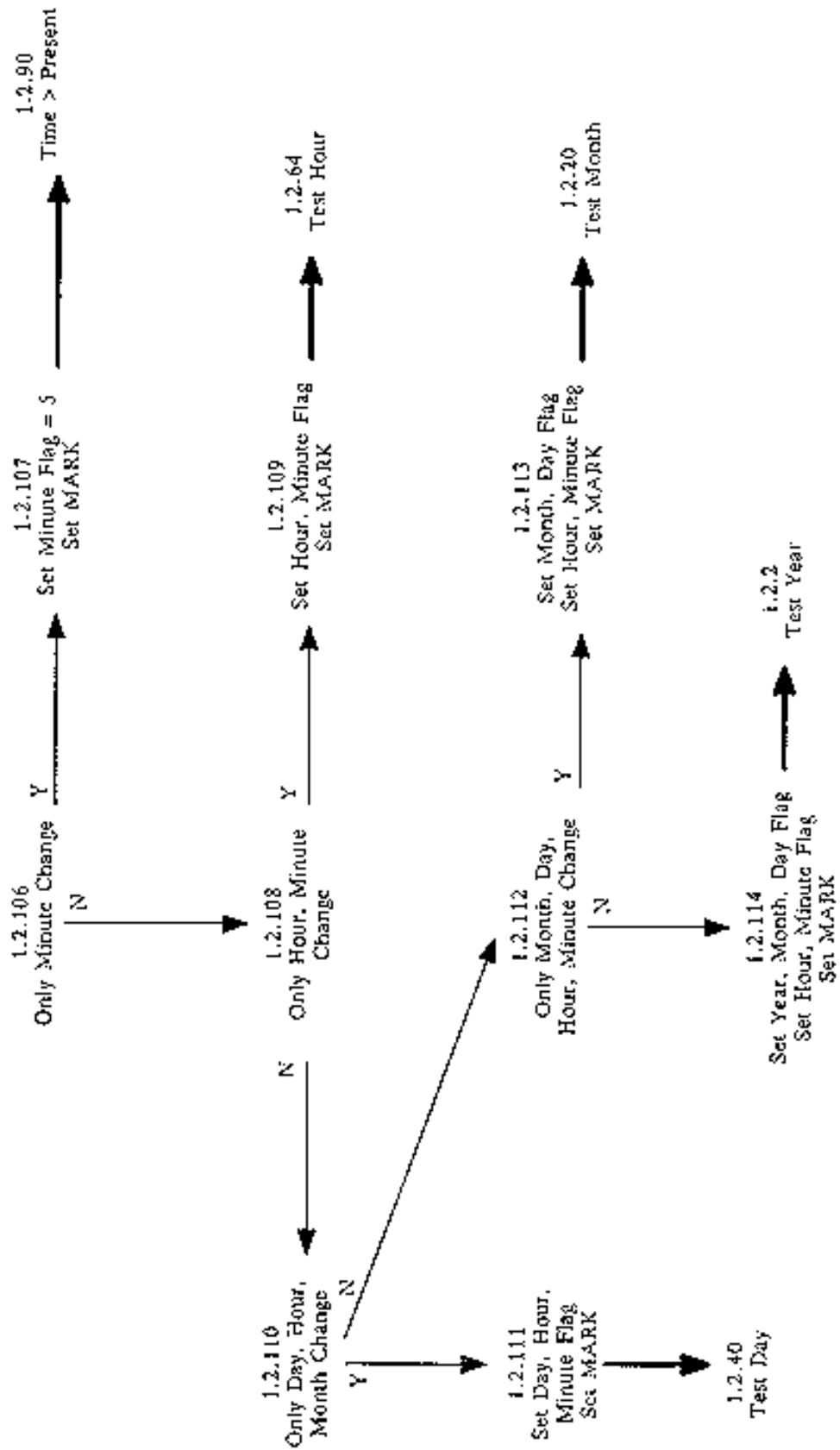

TEST NAME: 1.3 IMPOSSIBLE LOCATION

Prerequisites: Platform Identification Test
Impossible Date and Time Test
Sort the file by identifier and chronologically

Description:

This tests if the location of the observation is sensible. It does so by breaking the test into 2 parts. The two parts simply check that the latitude and longitude have possible values.

PART 1 begins by checking if the latitude lies between 90 degrees south and 90 degrees north inclusive. If it does, processing passes immediately to Part 2. If not, the identifier of the station is checked to see if it is known. If the identifier is known, the identifier, latitude, longitude, date and time of the station under consideration is listed. Also listed is the same information for all other stations with the same identifier in the incoming file. Processing then allows the user to flag the latitude as erroneous. If the identifier is not known the user may choose to flag the latitude as erroneous.

If the user chooses to flag the latitude as erroneous, the quality flag is set to be "4", and processing passes to Part 2.

If the user chooses not to flag the latitude as erroneous, a latitude may be inferred. If the user chooses not to do this, the quality flag is set to be "A" and processing passes to Part 2.

If an inference can be made, the user may do so. If the inference is accepted, the original value is preserved, the value changed to the new one, the quality flag set to be "S", changed and processing passes to Part 2.

PART 2 proceeds exactly the same as part 1 except the longitude is examined. In this case, the longitude must lie between 180 degrees west and 180 degrees east. Note that longitudes given using a different co-ordinate system must be converted. After the longitude is checked in this way, processing passes to the next station.

History: None

Rules:

Part 1:

- 1.3.1 IF: The latitude lies between plus or Minus 90 degrees
THEN : 1.3.13
ELSE : 1.3.2
- 1.3.2 IF: The identifier of the station is known
THEN: 1.3.3
ELSE: 1.3.4
- 1.3.3 : List the identifier, latitude, longitude and date of the station with the suspect latitude
: List the identifiers, latitudes, longitudes and dates of all of the stations
with the same identifier
: Display the track chart
: 1.3.4
- 1.3.4 IF: The user chooses to set the quality flag on the latitude as erroneous
THEN: 1.3.5
ELSE: 1.3.6
- 1.3.5 ; Set the quality flag on the latitude for the suspect station to be "A", erroneous

: 1.3.13

- 1.3.6 IF: The user chooses to infer the latitude
THEN: 1.3.7
ELSE: 1.3.5
- 1.3.7 IF: The user chooses to accept an inference
THEN: 1.3.9
ELSE: 1.3.8
- 1.3.8 IF: The user chooses to try to make another inference
THEN: 1.3.6
ELSE: 1.3.5
- 1.3.9 : Preserve the original value of the latitude
: Replace the original latitude with the inferred value
: Set the quality flag on the latitude, to be "5", changed
: 1.3.13

Part 2:

- 1.3.13 IF: The longitude lies between plus or minus 180 degrees
THEN: Test the next station
ELSE: 1.3.14
- 1.3.14 IF: The identifier of the station is known
THEN: 1.3.15
ELSE: 1.3.16
- 1.3.15 : List the identifier, latitude, longitude and date of the station with the suspect latitude
: List the identifiers, latitudes, longitudes and dates of all of the stations
with the same identifier
: Display the track chart
: 1.3.16
- 1.3.16 IF: The user chooses to set the quality flag on the longitude as erroneous
THEN: 1.3.17
ELSE: 1.3.18
- 1.3.17 : Set the quality flag on the longitude for the suspect station to be "4", erroneous
: Test the next station
- 1.3.18 IF: The user chooses to infer the longitude
THEN: 1.3.19
ELSE: 1.3.17
- 1.3.19 IF: The user chooses to accept an inference
THEN: 1.3.21
ELSE: 1.3.20
- 1.3.20 IF: The user chooses to try to make another inference
THEN: 1.3.18
ELSE: 1.3.17
- 1.3.21 : Preserve the original value of the longitude
: Replace the original longitude with the inferred value
: Set the quality flag on the longitude to be "5", changed
: Test the next station.

**1.3 Impossible Location
Part 1: Impossible Latitude**

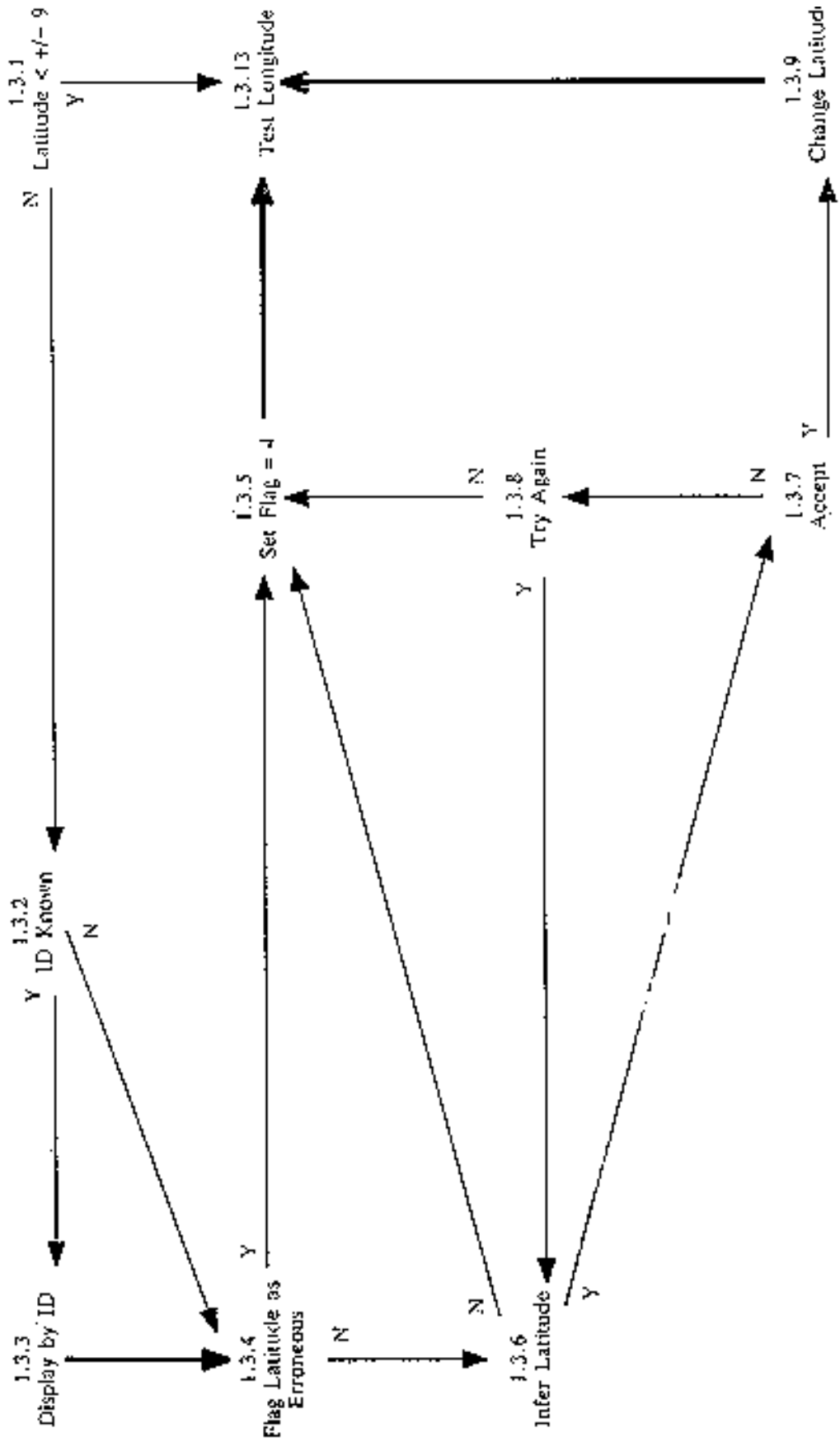

1.3 Impossible Location
Part 2: Impossible Longitude

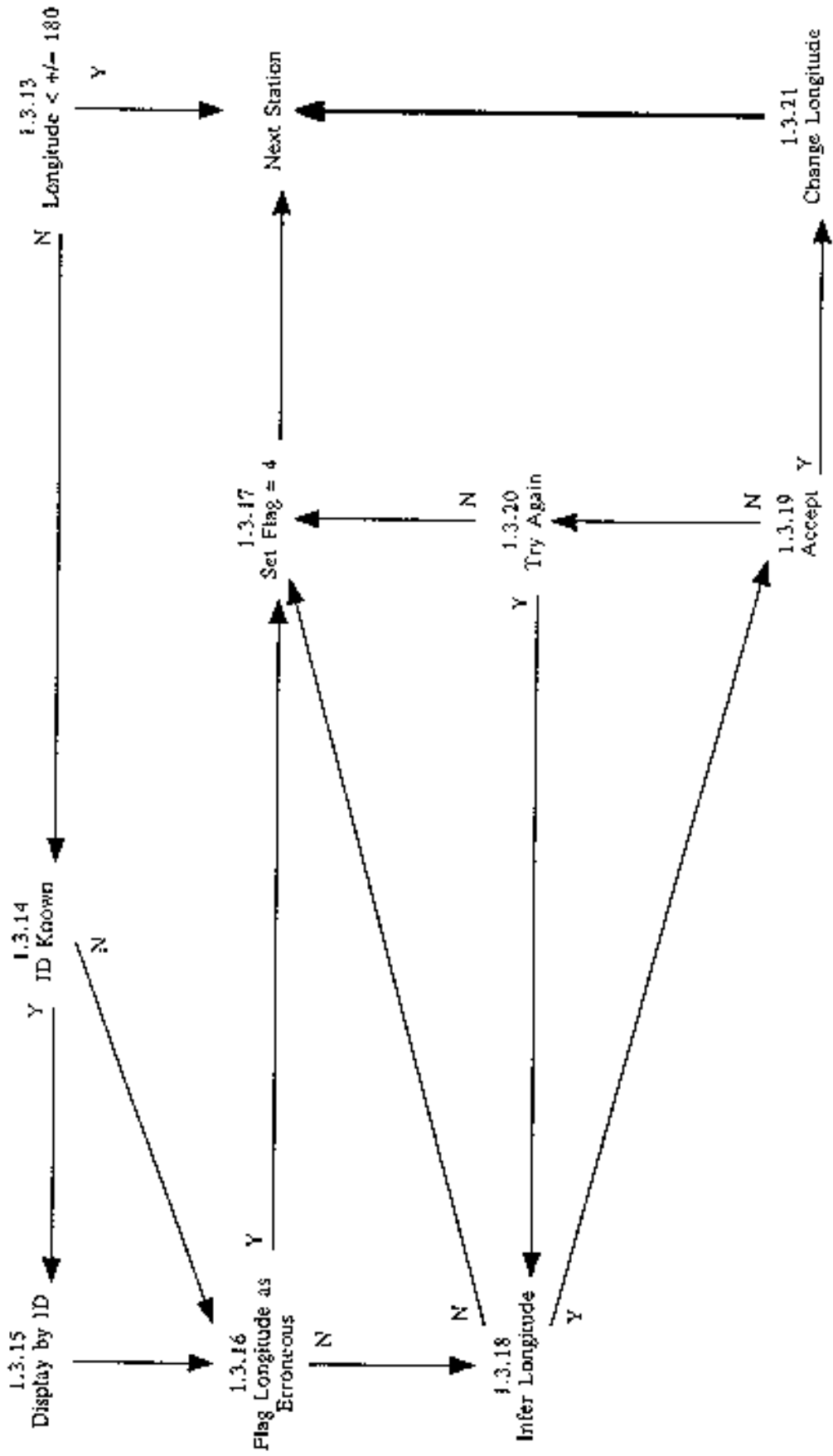

TEST NAME: 1.4 POSITION ON LAND

Prerequisites: Platform Identification Test
Impossible Date and Time Test
Impossible Position Test
A file of ocean bathymetry
Sort the file by identifier and chronologically.

Description:

This tests if the location of the observation is on land or water. It does so by comparing the location with a file of known bathymetric values. The user can choose to alter the recorded sounding, or the location of the station.

The test begins by checking if the latitude or longitude of the station has a quality flag set to be erroneous. If so, the next station is examined. If the position is not flagged as erroneous, then the position of the station is checked against a file of the ocean bathymetry to determine if the location is on land or not. If the station is at sea, it is examined to determine if there is a sounding and that the attached quality flag is not set to be erroneous. If there is no sounding, or if the value is flagged as erroneous, processing passes to the next station.

If the sounding is present and not flagged as erroneous, it is compared with the known water depth at the location of the station. If they agree, to within 10%, processing passes to the next station.

If the sounding and position do not agree, the identifier, date, time, position, sounding, depth from a bathymetry file and quality flags are displayed for the station under consideration and other stations in the neighbourhood. Also the track chart is displayed. The user can then choose to try to infer the correct sounding.

If the user chooses not to infer the sounding, the user can choose to flag the sounding as doubtful. If accepted, the quality flag is set to be "3" and processing passes to the next station. If the user chooses not to flag the sounding as doubtful, it is flagged as erroneous and processing automatically passes to the next station.

If the user accepts an inferred value, the original value is preserved, the inferred value replaces the original value, the quality flag on the sounding set to be changed, and processing passes to the next station.

If the station was determined to be on land, the identifier is examined to see if it is known. If not, the user can choose to flag the position as doubtful. If this is accepted, the quality flags on the latitude and longitude are set to be " 3 " and processing proceeds to the next station.

If the user rejects flagging the position as doubtful, the latitude and longitude are flagged as erroneous and processing proceeds to the next station.

If the identifier is known, the identifier, date, time, latitude, longitude and quality flags of the other stations with the same identifier are shown along with the same information for the suspect station. The user may choose to infer the correct position of the station. If the user chooses not to infer the position, they may choose to flag the position as doubtful as described above.

If the user chooses to accept the inference, the original value(s) of the position is preserved, the new values substituted, the quality flag set to be changed, and processing passes to check once more that the location is at sea. If the user chooses to not accept the inference, another may be tried. If no other is available or no other to be tried, the user can choose to flag the position as doubtful as described before.

History: None

Rules:

- 1.4.1 IF: The quality flag on the latitude or longitude is set to be erroneous
THEN : Test the next station
ELSE : 1.4.2
- 1.4.2 IF: The station location is at sea
THEN : 1.4.3
ELSE : 1.4.16
- 1.4.3 IF: There is a sounding value
THEN : 1.4.4
ELSE : Test the next station
- 1.4.4 IF: The value of the sounding is within 10% of the bathymetry at the location
THEN : Test the next station
ELSE : 1.4.5
- 1.4.5 : Display the identifier, date, time, latitude, longitude, sounding, depth and quality flags for the station under consideration
: Display the identifier, date, time, latitude, longitude, sounding, depth and quality flags for other stations in the neighbourhood of the, station under consideration
: 1.4.6
- 1.4.6 IF: The user chooses to infer the sounding
THEN : 1.4-7
ELSE : 1.4.13
- 1.4.7 IF: The user chooses to accept the inference
THEN : 1.4.9
ELSE : 1.4.8
- 1.4.8 IF: The user chooses to try another choice
THEN : 1.4.6
ELSE : 1.4.10
- 1.4.9 : Preserve the original value of the sounding
: Replace the sounding with the inferred value
: Set quality flag on the sounding to be "5", changed
: Test the next station
- 1.4.10 IF: The user chooses to flag the sounding as doubtful
THEN : 1.4.11
ELSE : 1.4.12
- 1.4.11 : Set the quality flag on the sounding to be "3", doubtful
: Test the next station
- 1.4.12 : Set the quality flag on the sounding to be "4", erroneous
: Test the next station
- 1.4.16 IF: The identifier of the station is known
: THEN 1.4.17
: ELSE 1.4.25
- 1.4.17 : Display the identifier, date, time, latitude, longitude, sounding, depth and quality flags for the station under consideration
: Display the identifier, date, time, latitude, longitude, sounding, depth and quality flags for

- other stations with the same identifier
 - : Display a track chart
 - : 1.4.18
- 1.4.18 IF: The user chooses to infer the position
 - THEN : 1.4.19
 - ELSE : 1.4.25
- 1.4.19 IF: The user chooses to accept the inference
 - THEN : 1.4.21
 - ELSE : 1.4.20
- 1.4.20 IF: The user chooses to try another choice
 - THEN : 1.4.18
 - ELSE : 1.4.25
- 1.4.21
 - : Preserve the original value of the position
 - : Replace the position with the inferred value
 - : Set quality flag on the position to be "5", changed
 - : 1.4.2
- 1.4.22 IF: The user chooses to flag the position as doubtful
 - THEN : 1.4.23
 - ELSE : 1.4.24
- 1.4.23
 - : Set the quality flag on the position to be "3", doubtful
 - : Test the next station
- 1.4.24
 - : Set the quality flag on the position to be "4", erroneous
 - : Test the next station

1.4 Position on Land
Part I

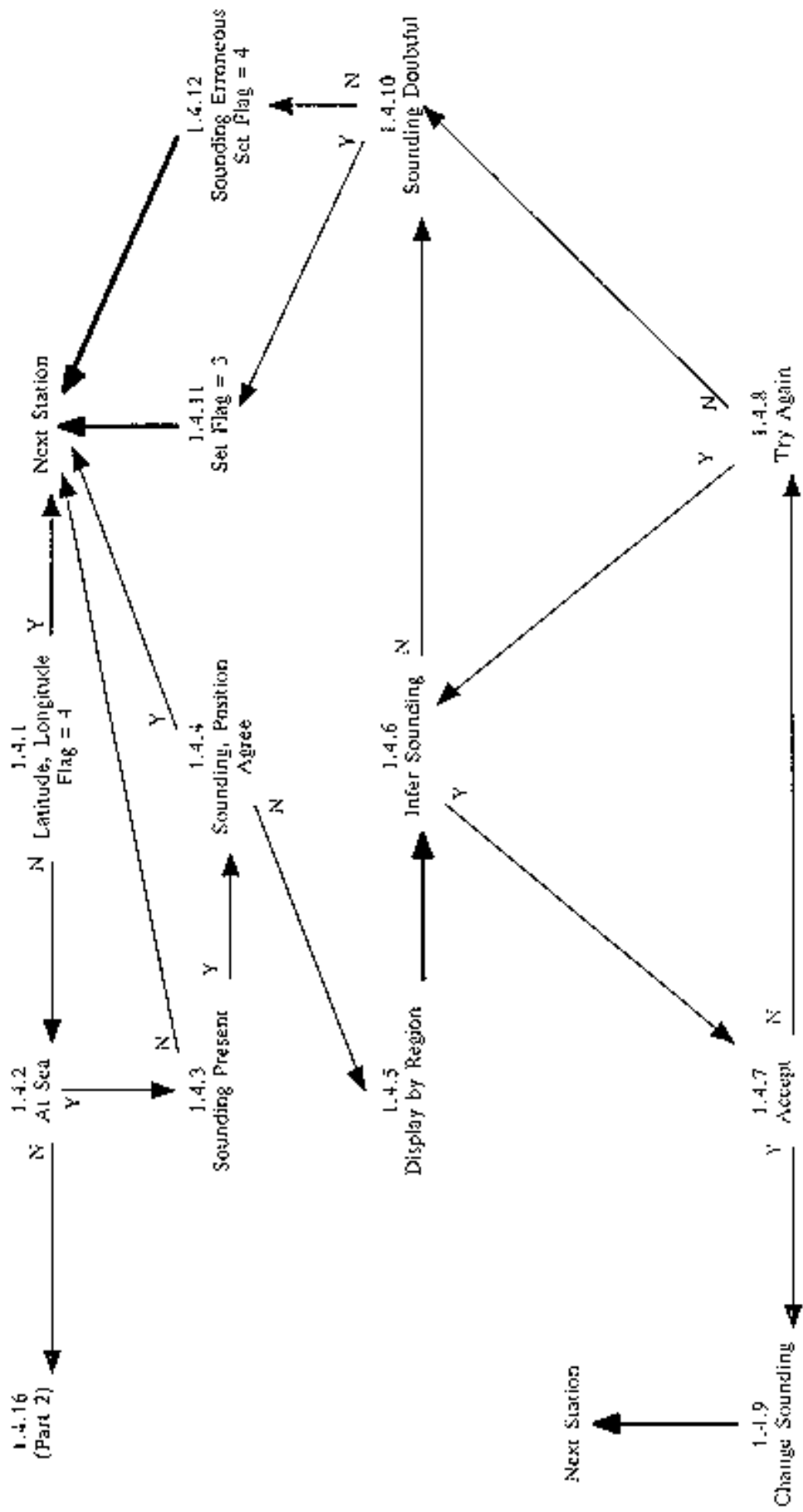

L.4 Position on Land
Part 2

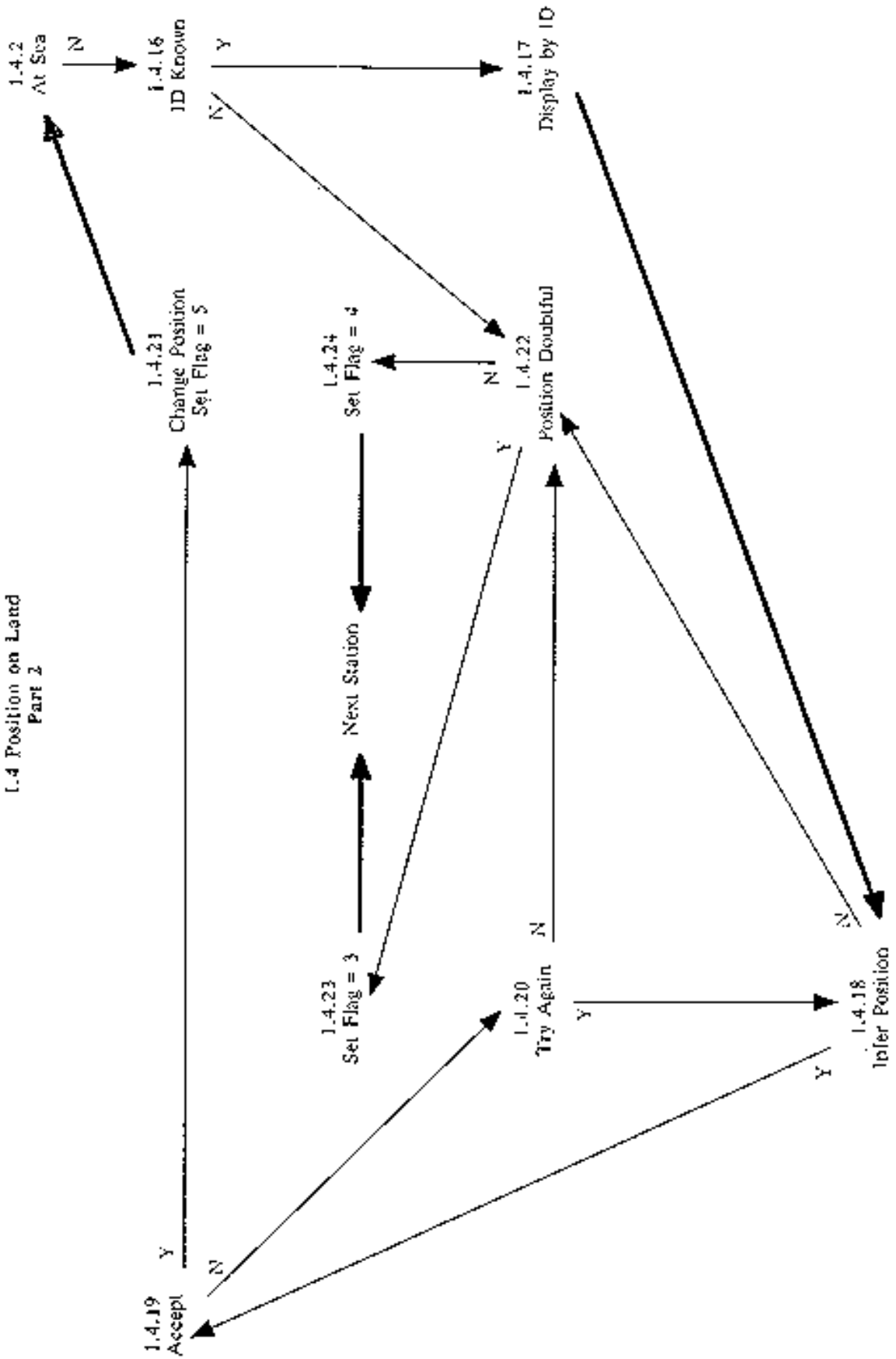

TEST NAME: 1.5 IMPOSSIBLE SPEED

Prerequisites: Platform Identification Test
Impossible Date and Time Test
Impossible Position Test
A file of ship identifiers and maximum possible speeds
Sort the file by identifier and chronologically.

Description:

This tests if the speed of the platform conforms to the characteristics known of the platform. It makes use of a table of platform identifiers that records the maximum speed possible for each. Note that it tests the speed between two stations and if a problem is found, it assumes the problem lies with the station later in time.

The test begins by checking if there is more than one station of the identifier under consideration. If not, no testing can be performed. If there is more than one station, the identifier of the platform is tested to determine, if it is known. If it is not, no test of the speed may be performed and testing passes to the next station. If the identifier is known, the quality flags on the position, date and time of the station is checked. If any of these flags are set to be erroneous, processing passes to the next station. If none are set to erroneous, the speed of the platform between the first two stations is calculated based on the separation in location and time. This is compared to the maximum allowed speed for the platform. If the speed does not exceed the maximum, the next station is used to calculate the speed between stations.

If the speed exceeds the maximum allowed, the identifier, latitude, longitude, date, time and quality flags for each are displayed for all of the stations with the identifier under consideration. A track chart is also displayed. The user may then choose to examine the position of the later station of the pair that was used to calculate speed.

If the user chooses to examine the position, they may then choose to infer the correct position. If this is not selected, the user may choose to set the quality flag on the position as doubtful. If this is accepted, the quality flag is set to be doubtful, a marker set and the next station tested.

If the user chooses not to flag the position as doubtful, they may choose to flag it as erroneous. If this is accepted, the quality flag is set to be erroneous, a marker set and the next station tested.

If the user chooses to infer a position and then accepts the choice, the original position is preserved, the new position substituted, the quality flag set to indicate the position to be changed, the marker set to indicate the position was examined and processing passes to allowing the user to choose if the date and time should be examined.

If the user chooses not to flag the position as erroneous, or if the user chooses not to examine the position, they may then choose to examine the date and time of the station later in time. If this is not accepted, a marker is tested to see if the position was examined. If it was, processing passes to the next station. If it was not set, a marker is examined to see if the date and time was checked. If set, processing passes to the next station. If neither marker has been set, the quality flags on the latitude, longitude date and time are all set to be doubtful, the user informed of this and processing passes to the next station.

If the user chooses to examine the date and time, then they may choose to infer the date and time. If they Choose not to, they can choose to flag the date and time as doubtful. If so, the quality flags on the year, month, day, hour and minute are set to be doubtful. Then processing passes to the next station. If the user chooses not to flag the date and time as doubtful, they can choose to flag them as erroneous. If so, the quality flags on the year, month, day, hour and minute are set to be doubtful. Then processing passes to the next station.

If the user chooses not to flag the date and time as erroneous, processing passes to ask the user if they wish to examine the position as described before.

The user may choose to infer the date and time and if they choose to accept it, the original value of the date and time are preserved, the new one substituted, the quality flag set to changed, and a marker set. Then if the marker indicating the position has already been looked at, processing passes to the next station. If the marker was not set, processing allows the user to choose if the position should be examined.

History: None

Rules:

- 1.5.1 IF: There is more than 1 station with the same identifier
THEN : 1.5.2
ELSE : Test the next station
- 1.5.2 IF: The identifier is known
THEN : 1.5.3
ELSE : Test the next station
- 1.5.3 IF: Either the latitude nor longitude have a quality flag set to be erroneous
THEN : Test the next station
ELSE : 1.5.4
- 1.5.4 IF: The year, month, day, hour or minute have a quality flag set to be erroneous
THEN : Test the next station
ELSE : 1.5.5
- 1.5.5 IF: The speed between the station in question and the next earlier station is less than or equal to the maximum speed for the platform
THEN : Test the next station
ELSE : 1.5.6
- 1.5.6 : Display the identifier, latitude, longitude, year, month, day, hour, minute and quality flags for the later station Display the identifier, latitude, longitude, year, month, day, hour, minute and quality flags for the earlier station Display a track chart
: 1.5.7
- 1.5.7 IF: The user chooses to examine the position
THEN : 1.5.8
ELSE : 1.5.20
- 1.5.8 IF: The user chooses to infer the position of the later station
THEN : 1.5.9
ELSE : 1.5.16
- 1.5.9 IF: The user chooses to accept the choice
THEN : 1.5.11
ELSE : 1.5.10
- 1.5.10 IF: The user chooses to try again
THEN : 1.5.8
ELSE : 1.5.13
- 1.5.11 : Preserve the original value of the position
: Change the value of the position according to the inferred value
: Set the quality flag on the position to be "5", changed the position marker

- : 1.5.12
- 1.5.12 IF: The date marker is set
 THEN : Test the next station
 ELSE : 1.5.20
- 1.5.13 IF: The user chooses to flag the position as doubtful
 THEN : 1.5.14
 ELSE : 1.5.15
- 1.5.14 : Set the quality flags on the latitude and longitude to be "3", doubtful
 : Test the next station
- 1.5.15 IF: The user chooses to flag the position as erroneous
 THEN : 1.5.16
 ELSE : 1.5.20
- 1.5.16 : Set the quality flags on the latitude and longitude to be "3", erroneous
 : Test the next station
- 1.5.20 IF: The user chooses to examine the date and time of the second station
 THEN : 1.5.24
 ELSE : 1.5.21
- 1.5.21 IF: The position marker has been set
 THEN : Test the next station
 ELSE : 1.5.22
- 1.5.22 IF: The date marker has been set
 THEN : Test the next station
 ELSE : 1.5.23
- 1.5.23 : Set the quality flags on the latitude and longitude to be "3", doubtful
 : Set the quality flags on the year, month, day, hour and minute to be doubtful
 : Test the next station
- 1.5.24 IF: The user chooses to infer the date and time of the later station
 THEN : 1.5.25
 ELSE : 1.5.29
- 1.5.25 IF: The user chooses to accept the choice
 THEN : 1.5.27
 ELSE : 1.5.26
- 1.5.26 IF: The user chooses to try again
 THEN : 1.5.24
 ELSE : 1.5.29
- 1.5.27 : Preserve the original value of the date and time
 : Change the value of the date and time according to the inferred value
 : Set the quality flag on the date to be "5", changed
 : Set the date marker
 : 1.5.28
- 1.5.28 IF: The position marker is set
 THEN : Test the next station
 ELSE : 1.5.7

- 1.5.29 IF: The user chooses to flag the date and time as doubtful
THEN : 1.5.30
ELSE : 1.5.31
- 1.5.30 : Set the quality flags on the year, month, day, hour and minute to be doubtful
: Test the next station
- 1.5.31 IF: The user chooses to flag the date and time as erroneous
THEN : 1.5.32
ELSE : 1.5.7
- 1.5.32 : Set the quality flags on the year, month, day, hour and minute to be erroneous
: Test the next station

1.5 Impossible Speed
Part 1

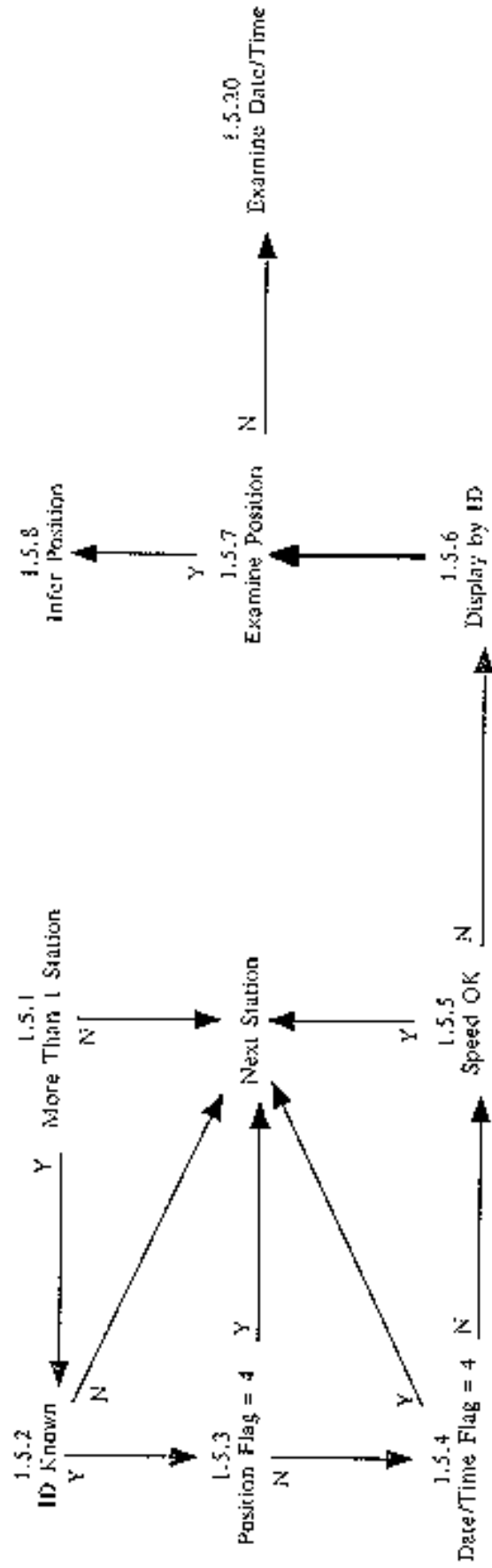

L.5 Impossible Speed
Part 2

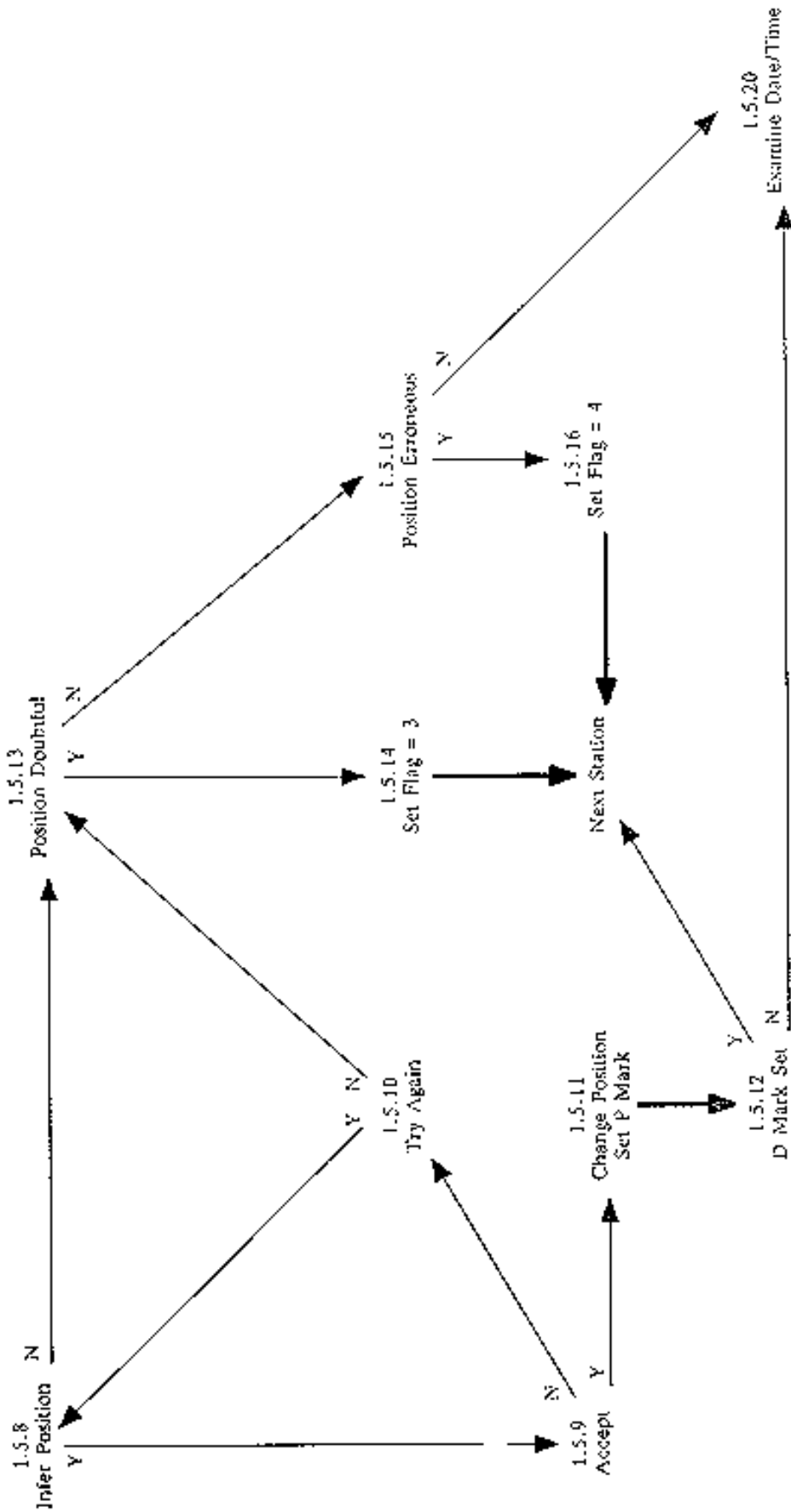

I.5 Impossible Speed
Part 3

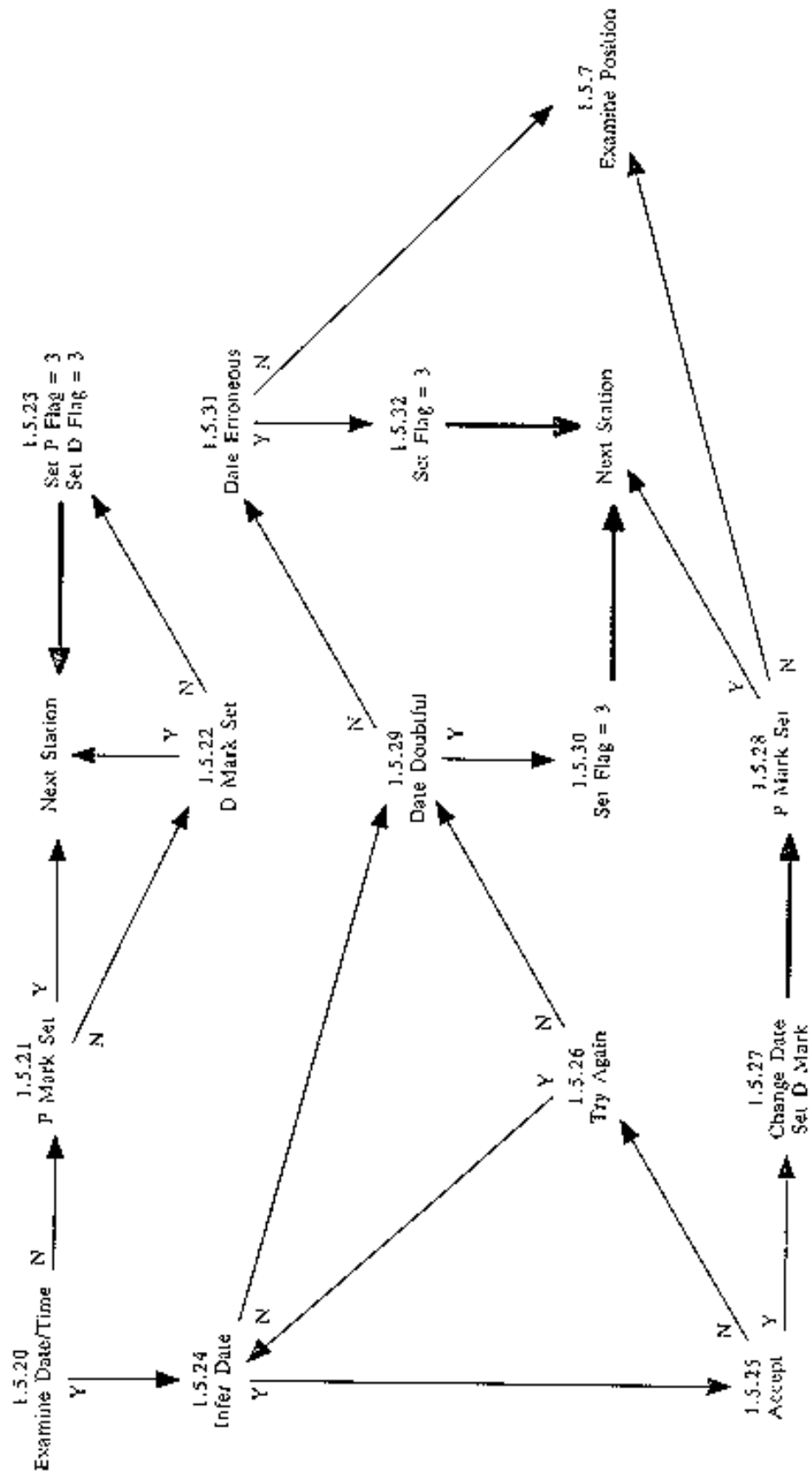

TEST NAME: 1.6 IMPOSSIBLE SOUNDING

Prerequisites:

Impossible Date and Time Test
Impossible Position Test
Sort the file by identifier and chronologically

Platform Identification Test

Description:

This tests if the sounding is sensible given a digital bathymetry.

The test begins by checking if the latitude or longitude of the station has a quality flag set to be erroneous. If so, the next station is examined. If the position is flagged as erroneous, the station is checked to see if the sounding is present. If present, the quality flag is set to be unchecked. If the sounding is not present, the next station is tested.

If the position is not flagged as erroneous, the station is checked to see if the sounding is present. If not present, the next station is tested. If the sounding is present, it is tested to be within 10% of the bathymetry. If it is, the quality flag on the sounding is set to be good.

If the sounding does not agree with the bathymetry, the user can choose to set the quality flag to be doubtful. If this is chosen, the quality flag is set to be doubtful. If the user chooses not to flag the sounding as doubtful, it is flagged as erroneous. No matter which flag is set, processing passes to test the next station.

History: None

Rules:

- 1.6.1 IF: The quality flag on the latitude or longitude is set to be erroneous
THEN : 1.6.2
ELSE : 1.6.4
- 1.6.2 IF: The sounding is present
THEN : 1.6.3
ELSE : Test the next station
- 1.6.3 : Set the quality flag on the sounding to be unchecked
: Test the next station
- 1.6.4 IF: The sounding is present
THEN : 1.6.5
ELSE : Test the next station
- 1.6.5 IF: The sounding is within 10% of the bathymetry
THEN : 1.6.6
ELSE : 1.6.7
- 1.6.6 : Set the quality flag on the sounding to be good
: Test the next station
- 1.6.7 IF: The user chooses to flag the sounding as doubtful
THEN : 1.6.8
ELSE : 1.6.9
- 1.6.8 : Set the quality flag on the sounding to be doubtful
: Test the next station
- 1.6.9 : Set the quality flag on the sounding to be erroneous
: Test the next station

1.6 Impossible Sounding

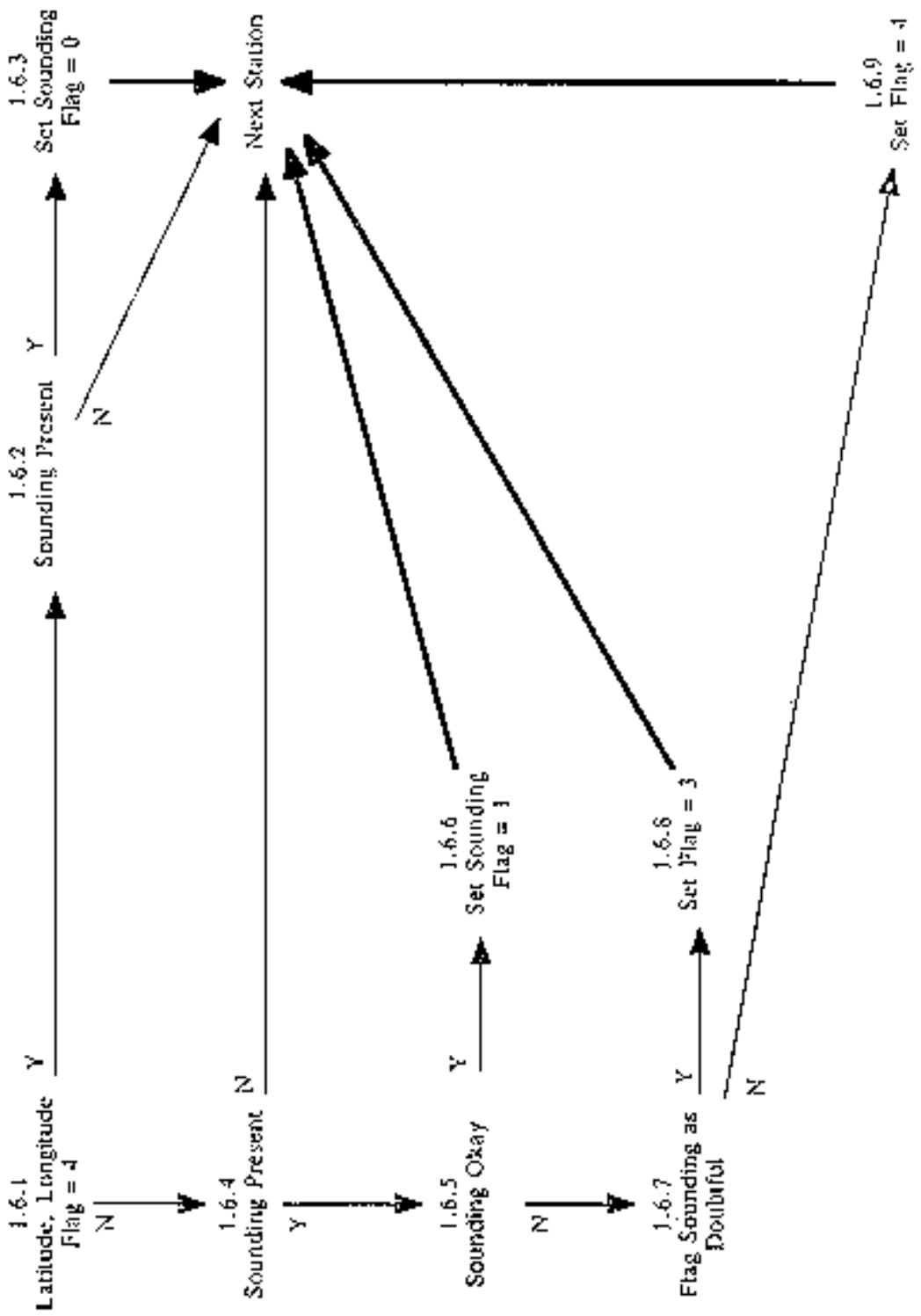

TEST NAME: 2.1 GLOBAL IMPOSSIBLE PARAMETER VALUES

Prerequisites: All of Stage 1 tests
The data should be sorted by identifier. For each unique identifier, the data should be sorted by increasing observation date and time ignoring any quality flags
All directional values should be converted on input to values between 0 and 360 degrees with north being zero degrees and east being 90 degrees.

Description:

These rules are used to check if observed parameter values are within probable globally defined limits. It begins by examining the first parameter at the shallowest depth and proceeds to look at other parameter values at the same depth before looking at values at the next depth. The test begins by examining if the parameter value exceeds the maximum recorded in table 2.1 below. If it does not, the value is tested against the minimum value as is described below. If it does exceed the maximum, the identifier for the profile is checked to see if it is known. If it is unknown, the identifier and value of the parameter at all depths of the profile are displayed. As well, the same information for the depth being considered in the suspect profile at other profiles in the neighbourhood are displayed. If the identifier is known, the identifier and value of the parameter at all depths of the profile and the same information for the depth being considered in the suspect profile for other profiles with the same identifier in the input file are displayed. In either case, the user can then choose to infer the value or not. If the user chooses not to enter the value, they may choose to flag the value as doubtful.

If an inference is made, the original value is changed, the original is preserved and the quality flag set to "changed". Then a marker is tested to see if the value has been tested against the minimum value. If so, the next parameter value is tested. If not, the test checks the value against the permitted minimum as in table 2.1 below.

If the user chooses to flag a value as doubtful, the quality flag is set to be doubtful. If not set as doubtful, it is set as erroneous. In either case, the marker is then tested as described above.

The test then goes on to test if the same parameter value is less than or equal to the minimum value recorded in table 2.1. If it is not, the parameter is tested to see if it is the wind direction. If not, the quality flag is tested to see if it has already been set. If so that next parameter is tested. If not, the quality flag is set to good, and the next parameter tested.

If the value is equal to the minimum, the parameter is examined further to see if it is recording a direction. If not, the quality flag is examined and if not set already, it is set to be good. If already set, or when set to good, the next parameter is tested.

If it is a direction, and the value is equal to the minimum, and the data source uses this minimum to indicate calm conditions, the quality flag is examined if any of these conditions are not met. If all of the conditions are met, the corresponding speed value is examined. For example, if wind direction was the parameter derived from an IGOSS source, and the value was zero, the wind speed value would be tested. If the speed value is zero, the quality flag is examined. If not zero, the identifier is examined to see if it is known. If it is unknown, the identifier, speed and direction at all depths of the profile are displayed. As well, the same information for the depth being considered in the suspect profile at other profiles in the neighbourhood are displayed. If the identifier is known, the identifier, speed and direction at all depths of the profile and the same information for the depth being considered in the suspect profile for other profiles with the same identifier in the input file are displayed. In either case, the user can then choose to infer either the speed or direction value.

If an inference is made, the original value is saved and the quality flag set to "changed". Then the next parameter is tested.

If the user chooses not to infer a value, they may choose to flag the value as doubtful. If this is not accepted, the value is flagged as erroneous. In either case, the next parameter is then tested.

Table 2.1: Global Impossible Parameter Values

PARAMETER	MIN	MAX	
Wind Speed	0	60	m/sec
Wind Direction	0	360	degrees
Air Temperature (Dry)	-80	40	degrees C
Air Pressure	850	1060	hectoPascals
Air Pressure Tendency	-30	30	hPa/hour
Water Temperature	-2.5	35	degrees C
Salinity	0	40	psu
Current Speed	0	3	m/sec
Current Direction	0	360	degrees
Cloud Code	0	9	
Air Pressure	950	1050	mb
Weather Code	0	9	
Wave Period	0	20	sec
Wave Height	0	30	m
Sounding	0	10000	m
Depth	0	10000	m

History: None

Rules:

- 2.1.1 IF: The parameter value is greater than the maximum value in table 2.1
THEN : 2.1.2
ELSE : Set the marker 2.1.16
- 2.1.2 IF: The identifier is known
THEN : 2.1.3
ELSE : 2.1.4
- 2.1.3 : Display the identifier and parameter values for the profile with the suspect value
: Display the identifiers and parameter values for all other stations with the same identifier
in the incoming file and at the same depth as the suspect value
: 2.1.5
- 2.1.4 : Display the identifier and parameter values for the profile with the suspect value
: Display the identifiers and parameter values for other stations in the incoming file and in
the neighbourhood of the profile in question and at the same depth as the suspect value
: 2.1.5
- 2.1.5 IF: The user wishes to infer the value
THEN : 2.1.9
ELSE : 2.1.6
- 2.1.6 IF: The user wishes to flag the value as doubtful
: THEN 2.1.7
: ELSE 2.1.8
- 2.1.7 : Set the quality flag on the value to be "3", doubtful
: 2.1.12
- 2.1.8 : Notify the user that the quality flag is set to erroneous
: Set the quality flag on the value to be "4", erroneous
: 2.1.12

- 2.1.9 IF: The user chooses to accept an inference
 THEN : 2.1.11
 ELSE : 2.1.10
- 2.1.10 IF: The user chooses to try again
 THEN : 2.1.5
 ELSE : 2.1.6
- 2.1.11 : Preserve the original value
 : Reset the parameter value to the new value
 : Set the quality flag on the parameter to "5", changed'
 : 2.1.12
- 2.1.12 IF: A marker is set indicating that the value has been tested against the maximum value
 THEN : Clear the marker
 : Test the next parameter
 ELSE : Set the marker to indicate the value has been tested against the maximum
 : 2.1.16
- 2.1.16 IF: The parameter value is less than the minimum value in table 2.1
 THEN : 2.1.2
 ELSE : 2.1.17
- 2.1.17 IF: The parameter is a direction
 THEN : 2.1.20
 ELSE : 2.1.18
- 2.1.18 IF: The quality flag is already set
 THEN : Clear the marker
 : Test the next parameter
 ELSE : 2.1.19
- 2.1.19 : Set the quality flag to be good
 : Clear the marker
 : Test the next parameter
- 2.1.20 IF: The parameter value equals the minimum value in table 2.1
 THEN : 2.1.21
 ELSE : 2.1.18
- 2.1.21 IF: The data source uses the minimum direction value to indicate calm conditions
 THEN : 2.1.22
 ELSE : 2.1.18
- 2.1.22 IF: The corresponding parameter value for speed has a value of zero
 THEN : 2.1.18
 ELSE : 2.1.23
- 2.1.23 IF: The identifier of the profile is known
 THEN : 2.1.25
 ELSE : 2.1.24
- 2.1.24 : Display the identifier, speed and direction for the profile with the suspect value
 : Display the identifier, speed and direction for other stations in the incoming file and in the
 neighbourhood of the profile in question and at the same depth as the suspect value
 : 2.1.26

- 2.1.25 : Display the identifier, speed and direction for the profile with the suspect value
: Display the identifier, speed and direction for all other stations with the same identifier in the incoming file and at the same depth as the suspect value
: 2.1.26
- 2.1.26 IF: The user chooses to infer the speed and/or direction
THEN : 2.1.30
ELSE : 2.1.27
- 2.1.27 IF: The user chooses to flag the value as doubtful
THEN : 2.1.28
ELSE : 2.1.29
- 2.1.28 : Set the quality flag on the value to be "3", doubtful
: Clear the marker
: Test the next parameter
- 2.1.29 : Notify the user that the quality flag is set to erroneous
: Set the quality flag on the value to be "4", erroneous
: Clear the marker
: Test the next parameter
- 2.1.30 IF: The user chooses to accept an inference
THEN : 2.1.32
ELSE : 2.1.31
- 2.1.31 IF: The user chooses to try again
THEN : 2.1.29
ELSE : 2.1.27
- 2.1.32 : Preserve the original value of speed and/or direction
: Reset the speed and/or direction to the new value(s)
: Set the quality flag on the speed and/or direction to "5", changed
: Clear the marker
: Test the next parameter

2.1 Global Impossible Parameter Values
Part 3

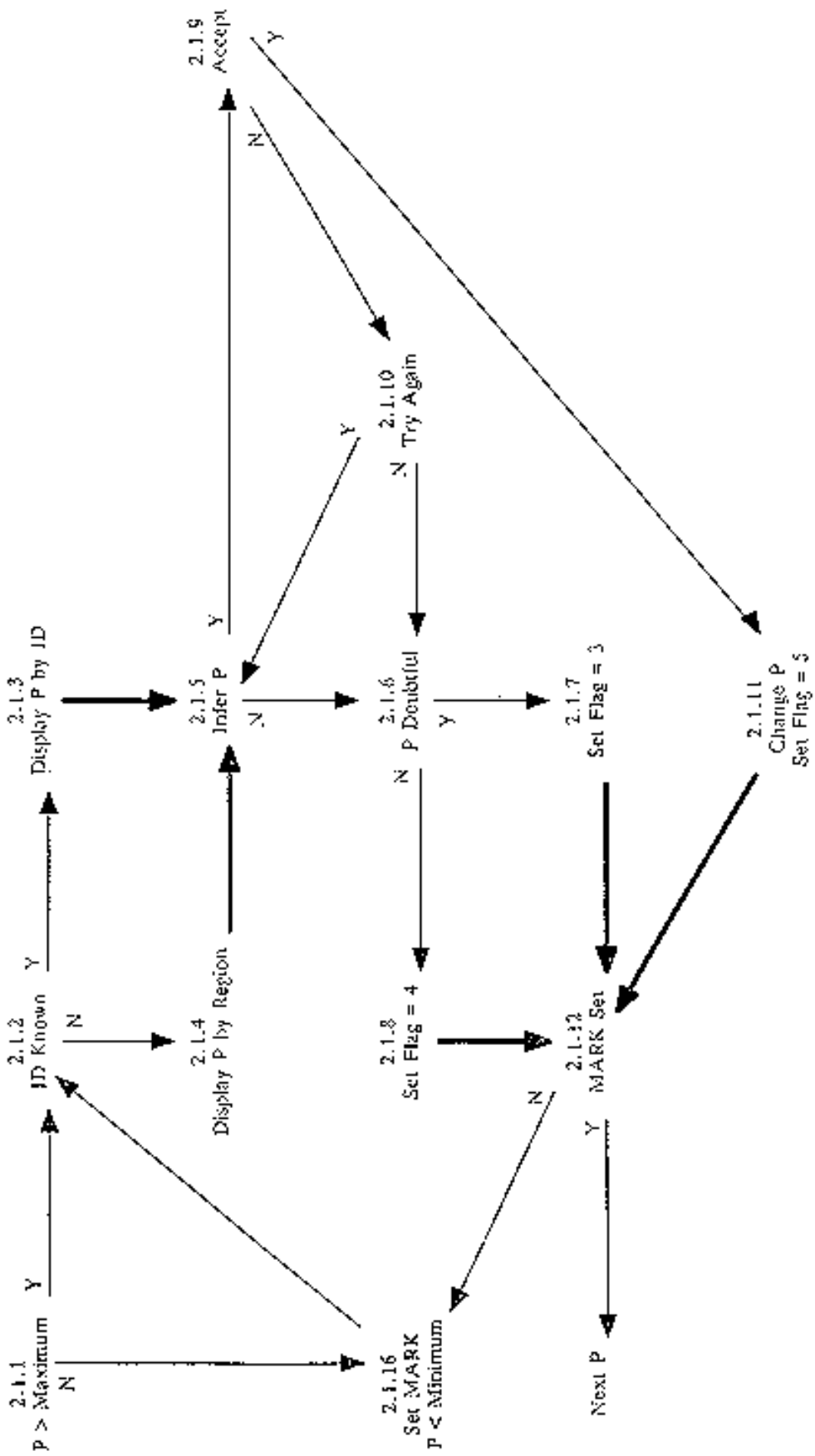

2.1 Global Impossible Parameter Values
Part 2A

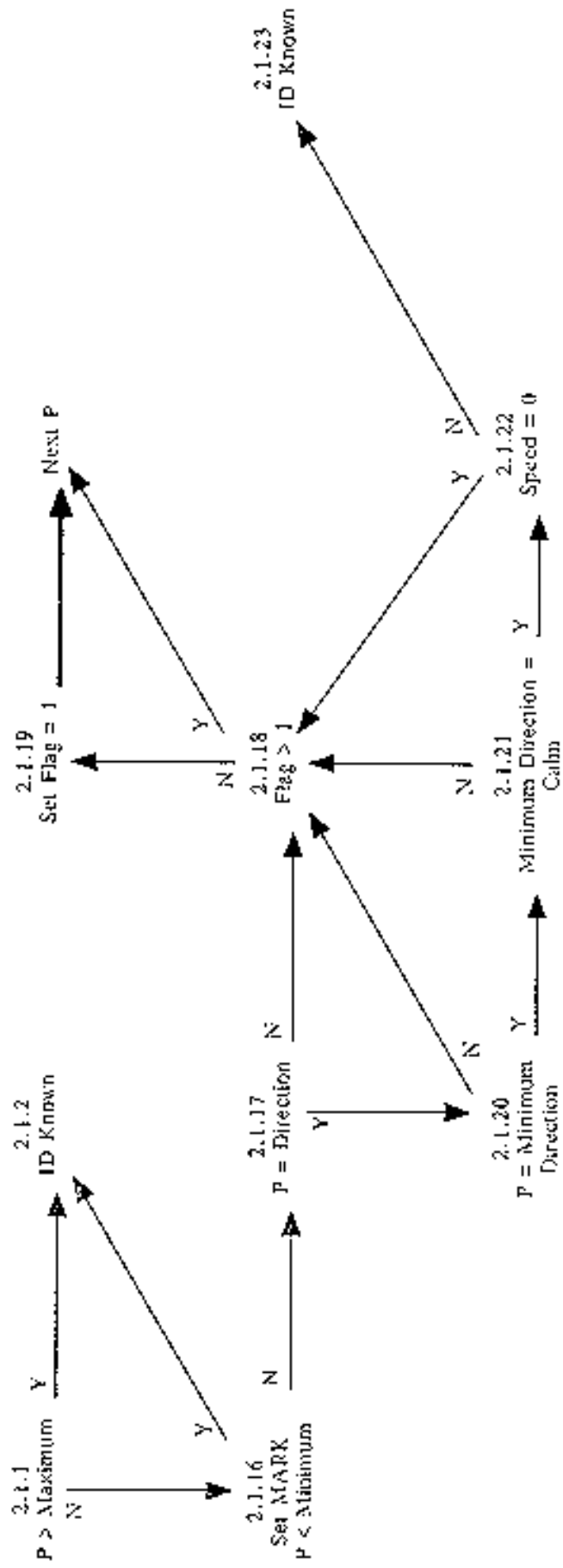

2.1 Global Impossible Parameter Values
Part 2B

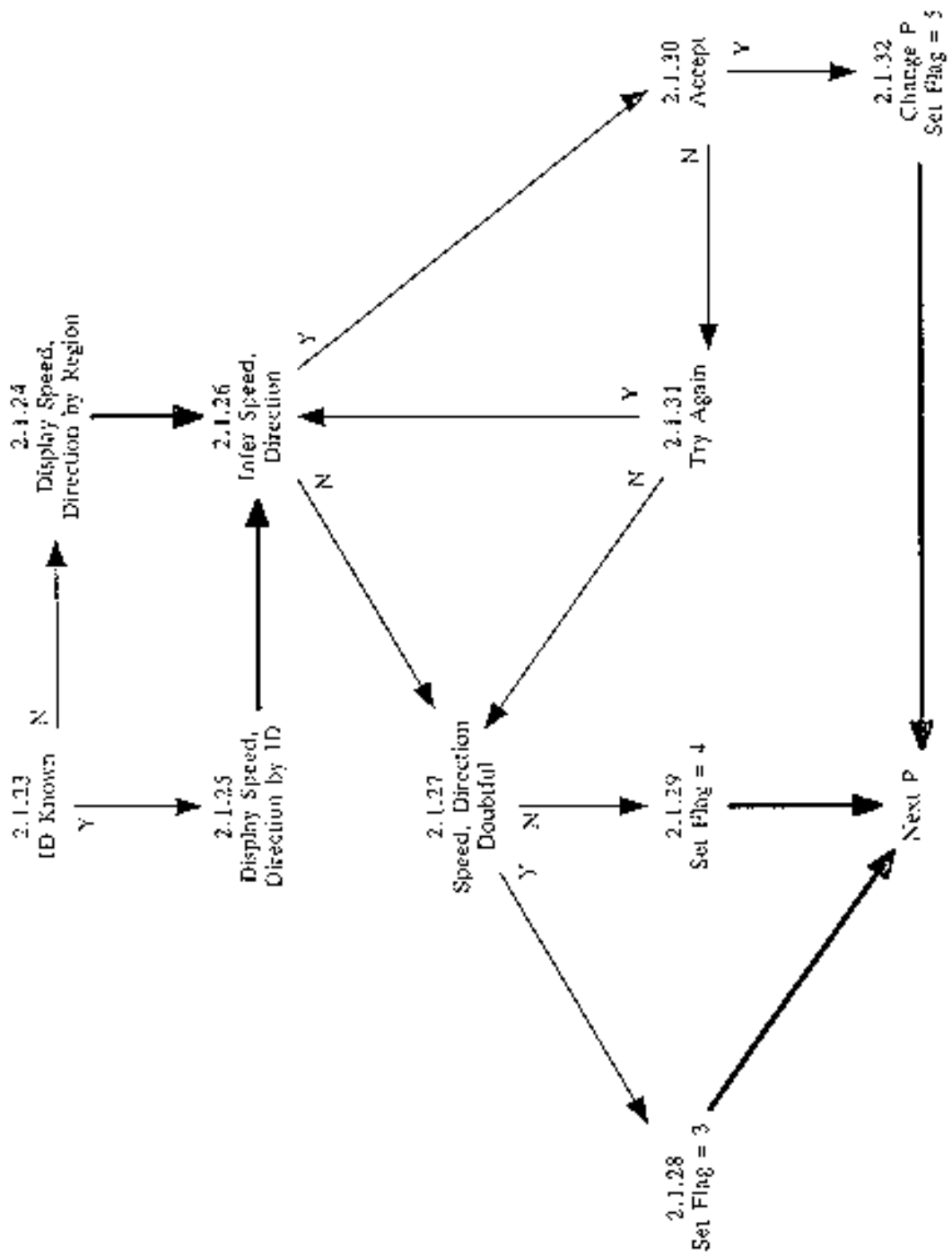

TEST NAME: 2.2 REGIONAL IMPOSSIBLE PARAMETER VALUES

Prerequisites: All of Stage 1 tests
Global Impossible Parameter Values Test

The data should be sorted by identifier. For each unique identifier, the data should be sorted by increasing observation date and time ignoring any quality flags

All directional values should be converted on input to values between 0 and 360 degrees with north being zero degrees and east being 90 degrees.

Description:

This test allows for a more precise examination of parameter values based on the geographic region in which the observation was made. To begin, the quality flags on the latitude and longitude are examined. If either is flagged as erroneous, the data from the next station are examined. If the position is not erroneous, and the station lies within the boundaries of a geographic region given in table 2.2, then the parameter value is tested against values given in the same table. If no test is given, the data at the next station are tested. If the data lie within a region defined in Table 2.2, the same rules, and logic is used as in the Global Impossible Parameter Test.

Table 2.2 Regional Impossible Parameter Values

REGION NAME	LOCATION	
Mediterranean Sea	30N,4E; 30N,40E; 40N,35E; 42N,20E; 50N,15E; 40N,5E; 30N,4E	
PARAMETER	MIN	MAX
Water temperature	13.0	40.0 degrees C
Depth/sounding	0.0	5200 m
Red Sea	10N,40E; 20N,50E; 30N,30E; 10N,40E	

PARAMETER	MIN	MAX
Water temperature	21.7	40.0 degrees C
Depth/sounding	0.0	3500 m

History: None

Rules:

- 2.2.1 IF: The latitude or longitude has a quality flag of erroneous
THEN : Test the next station
ELSE : 2.2.2
- 2.2.2 IF: The station lies within a region(s) defined in table 2.2
THEN : 2.2.3
ELSE : Test the next station
- 2.2.3 : (Execute the rules of the Global Impossible Parameter Test)

2.2 Impossible Regional Parameter Value

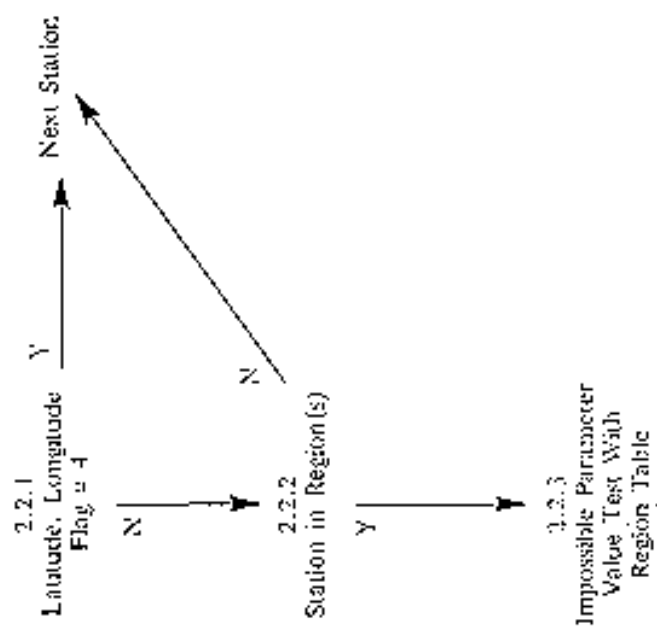

TEST NAME:**2.3 INCREASING DEPTH****Prerequisites:**

All of Stage 1 tests

Depths are ordered from shallowest to deepest in a profile

Description:

These rules test if the depths of the observations are monotonically increasing. DEPTH1 always refers to the depth being examined, DEPTH2 to another depth at the station. The test begins by determining if there is more than one depth in the profile. If not, the next profile is examined. If there is more than one depth, DEPTH1 is set to the first depth and the quality flag is examined. If this quality flag is set to erroneous, DEPTH1 is tested to determine if it is the deepest in the profile. If it is, the next profile is examined. If it is not, DEPTH1 is set to the next depth, and this test of the quality flag repeated. If DEPTH1 is not indicated as erroneous, DEPTH2 is set to be the next depth and the quality flag on it is tested. If it is set as erroneous, DEPTH2 is tested if it is the deepest. If so, the next profile is examined. If not, DEPTH2 is set to the next depth and the test of the quality flags repeated. If the quality flag is not set to erroneous, DEPTH2 is tested to be greater than DEPTH1. If it is greater, DEPTH1 is set to DEPTH2.. Then, DEPTH2 is tested to determine if it is the deepest in the profile as described above. If DEPTH2 is not greater than DEPTH1, the user can flag DEPTH2 as doubtful or erroneous. In either case, DEPTH1 is set to DEPTH2 and the process repeats down the profile until the deepest depth is tested. At this point, the next profile is tested.

History: None**Rules:**

- 2.3.1 IF: There is more than 1 depth in the profile
THEN : 2.3.2
ELSE : Test the next profile
- 2.3.2 : Set DEPTH1 to be the first depth
: 2.3.3
- 2.3.3 IF: The value of DEPTH1 has a quality flag set to be erroneous
THEN : 2.3.4
ELSE : 2.3.6
- 2.3.4 IF: DEPTH1 is the deepest depth in the profile
THEN : Test the next profile
ELSE : 2.3.5
- 2.3.5 : Set DEPTH1 to be the next depth in the profile
: 2.3.3
- 2.3.6 : Set DEPTH2 to be the next depth in the profile
: 2.3.7
- 2.3.7 IF: The value of DEPTH2 has a quality flag set to be erroneous
THEN : 2.3.8
ELSE : 2.3.9
- 2.3.8 IF: DEPTH2 is the deepest depth in the profile
THEN : Test the next profile
ELSE : 2.3.6
- 2.3.9 IF: DEPTH2 is deeper than DEPTH1
THEN : 2.3.10
ELSE : 2.3.11

- 2.3.10 : Change the quality flag on the depth from "0", unchecked, to "1", correct
: Set DEPTH1 = DEPTH2
: 2.3.8
- 2.3.11 IF: The user chooses to flag DEPTH2 as doubtful
THEN : 2.3.12
ELSE : 2.3.13
- 2.3.12 : Set the quality flag on DEPTH2 to "3", doubtful
: Set DEPTH1 = DEPTH2
: 2.3.8
- 2.3.13 : Notify the user that the value is flagged as erroneous
: Set the quality flag on DEPTH2 to "4", erroneous
: Set DEPTH1 = DEPTH2
: 2.3.4

2.3 Depth Increasing

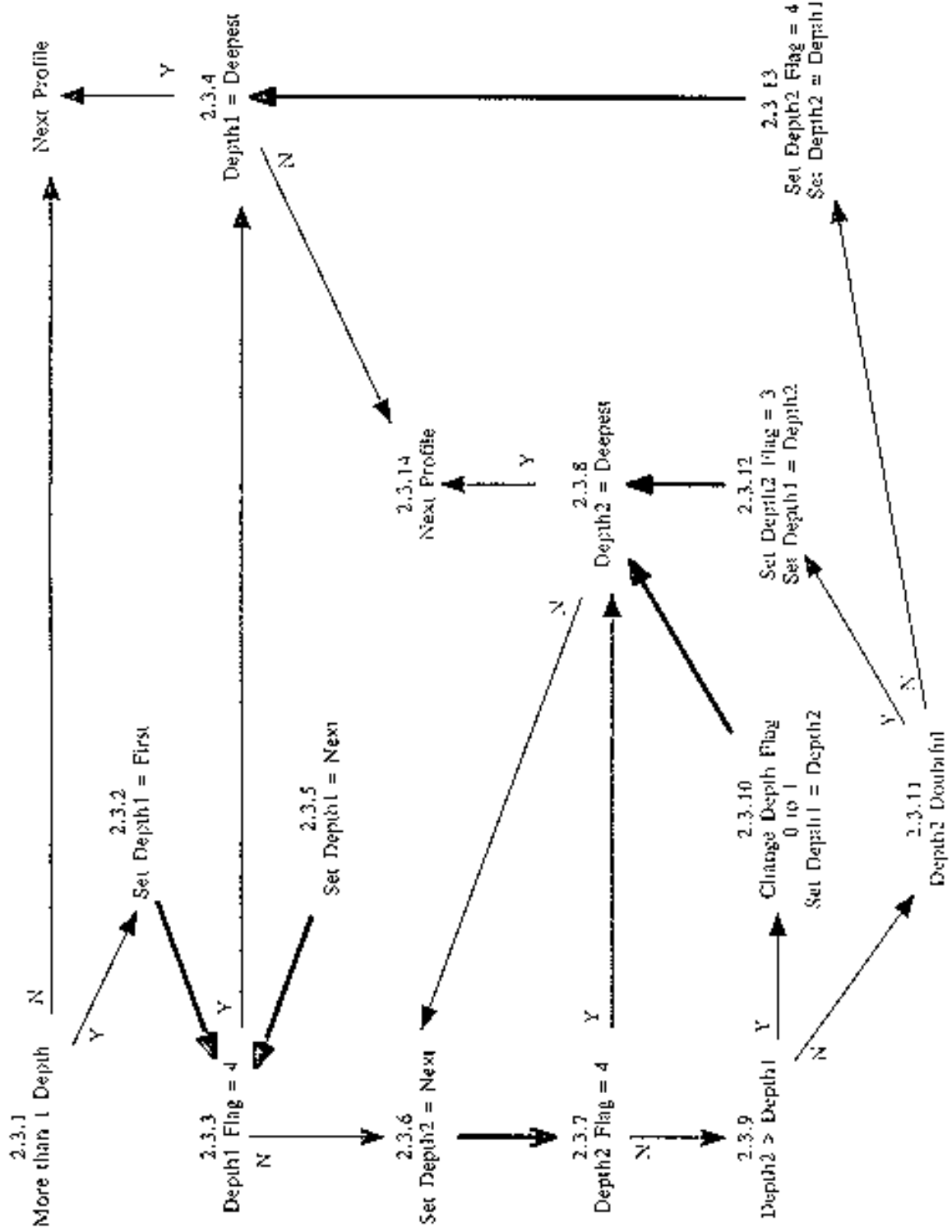

TEST NAME: 2.4 GLOBAL PROFILE ENVELOPE

Prerequisites: All of Stage 1 tests.
Global Impossible Parameter Value test.
Parameter values are ordered from shallowest to deepest depth
Profiles are sorted by identifier, then increasing date and time for each identifier

Description:

These rules test if the observed values lie within an envelope of permitted values within depth ranges. It begins by ensuring that the first parameter recorded at a station has a defined envelope. If not, it tests if there is another parameter at the station to test. If not, the next station is tested. If there is another parameter at the station, it is tested to see if there is a defined envelope as just described.

If an envelope is defined for the parameter profile under consideration, the quality flag for the first depth is examined. If it is set to erroneous, the depth is tested to see if it is the deepest. If so the station is tested to see if there is another parameter to be tested. If the depth is not the deepest, the depth is set to be the next, and the quality flag on the depth tested as described.

If the quality flag on the depth is not set to erroneous, the quality flag on the parameter value is examined. If it is set to erroneous, the depth is examined to see if it is the deepest.

If the parameter flag is not set to erroneous, the parameter value is tested to lie within the envelope defined in table 2.4. If it lies within, the depth is tested if it is the deepest. If the value lies outside of the envelope the identifier of the station is examined to see if it is known. If not, the entire parameter profile and quality flags are displayed. The parameter values and quality flags at the same depth and at stations in the neighbourhood of the station with the suspect value are also displayed. If the identifier is known, the same information as above is displayed but now for stations with the same identifier as the station with the suspect value. The user can then choose to infer the value of the suspect parameter.

If the user chooses to infer the value, it may be flagged as doubtful. If this is selected, the quality flag on the value is set to be doubtful, and the depth tested to determine if it is the deepest. If the user rejects flagging the value as doubtful, it is flagged as erroneous, and the depth tested as just described.

The user may choose to infer the value, the results are displayed and then may choose to accept it or not. If accepted, the old value is preserved, the new value substituted for it and the quality flag set to changed. If the user rejects the choice, they may choose to try again or flag the profile as doubtful.

Table 2.4: Parameter envelopes

Depth Range (metres)	Temperature (degrees C)	Salinity (psu)
0 to 50	-2.5 to 35.0	0.0 to 40.0
>50 to 100	-2.5 to 30.0	1.0 to 40.0
>100 to 400	-2.5 to 28.0	3.0 to 40.0
>400 to 1100	-2.0 to 27.0	10.0 to 40.0
>1100 to 3000	-1.5 to 18.0	22.0 to 38.0
>3000 to 5500	-1.5 to 7.0	33.0 to 37.0
> 5500	-1.5 to 4.0	33.0 to 37.0

History: None

Rules:

- 2.4.1 : Set the first parameter to be the one to consider
- : Set the depth to be the shallowest in the profile
- : 2.4.2

- 2.4.2 IF: An envelope is defined for the parameter
THEN : 2.4.5
ELSE : 2.4.3
- 2.4.3 IF: There is another parameter profile at the station
THEN : 2.4.4
ELSE : Test the next station
- 2.4.4 : Set the parameter under consideration to be the next for the station
: Set the depth to be the shallowest for the parameter
: 2.4.2
- 2.4.5 IF: The quality flag on the depth is set to be erroneous
THEN : 2.4.6
ELSE : 2.4.8
- 2.4.6 IF: The depth is the deepest for that parameter in the profile
THEN : 2.4.3
ELSE : 2.4.7
- 2.4.7 : Set the depth to be the next deeper in the profile
: 2.4.5
- 2.4.8 IF: The quality flag on the parameter is set to erroneous
THEN : 2.4.6
ELSE : 2.4.9
- 2.4.9 IF: The parameter value lies within the envelope defined in table 2.4
THEN : 2.4.6
ELSE : 2.4.10
- 2.4.10 IF: The identifier of the station is known
THEN : 2.4. 11
ELSE : 2.4.12
- 2.4.11 : Display the identifier, parameter values and quality flags at all depths in the profile under consideration
: Display the identifier, parameter values and quality flags at the same depth as the suspect value at all stations with the same identifier as the suspect station
: 2.4.13
- 2.4.12 : Display the identifier, parameter values and quality flags at all depths in the profile under consideration
: Display the identifier, parameter values and quality flags at the same depth as the suspect value at all stations in the neighbourhood of the suspect station
: 2.4.13
- 2.4.13 IF: The user chooses to infer the parameter value
THEN : 2.4.17
ELSE : 2.4.14
- 2.4.14 IF: The user chooses to flag the value as doubtful
THEN : 2.4.15
ELSE : 2.4.16
- 2.4.15 : Set the quality flag on the value to "3", doubtful
: 2.4.6

- 2.4.16 : Set the quality flag on the value to "4", erroneous
: 2.4.6
- 2.4.17 IF: The user chooses to accept an inference
THEN : 2.4.19
ELSE : 2.4.18
- 2.4.18 IF: The user chooses to try again
THEN :2.4.13
ELSE : 2.4.14
- 2.4.19 : Preserve the original value of the parameter
: Reset the parameter value to the new value
: Set the quality flag on the parameter to "5", changed
: 2.4.6

2.4 Global Profile Envelope

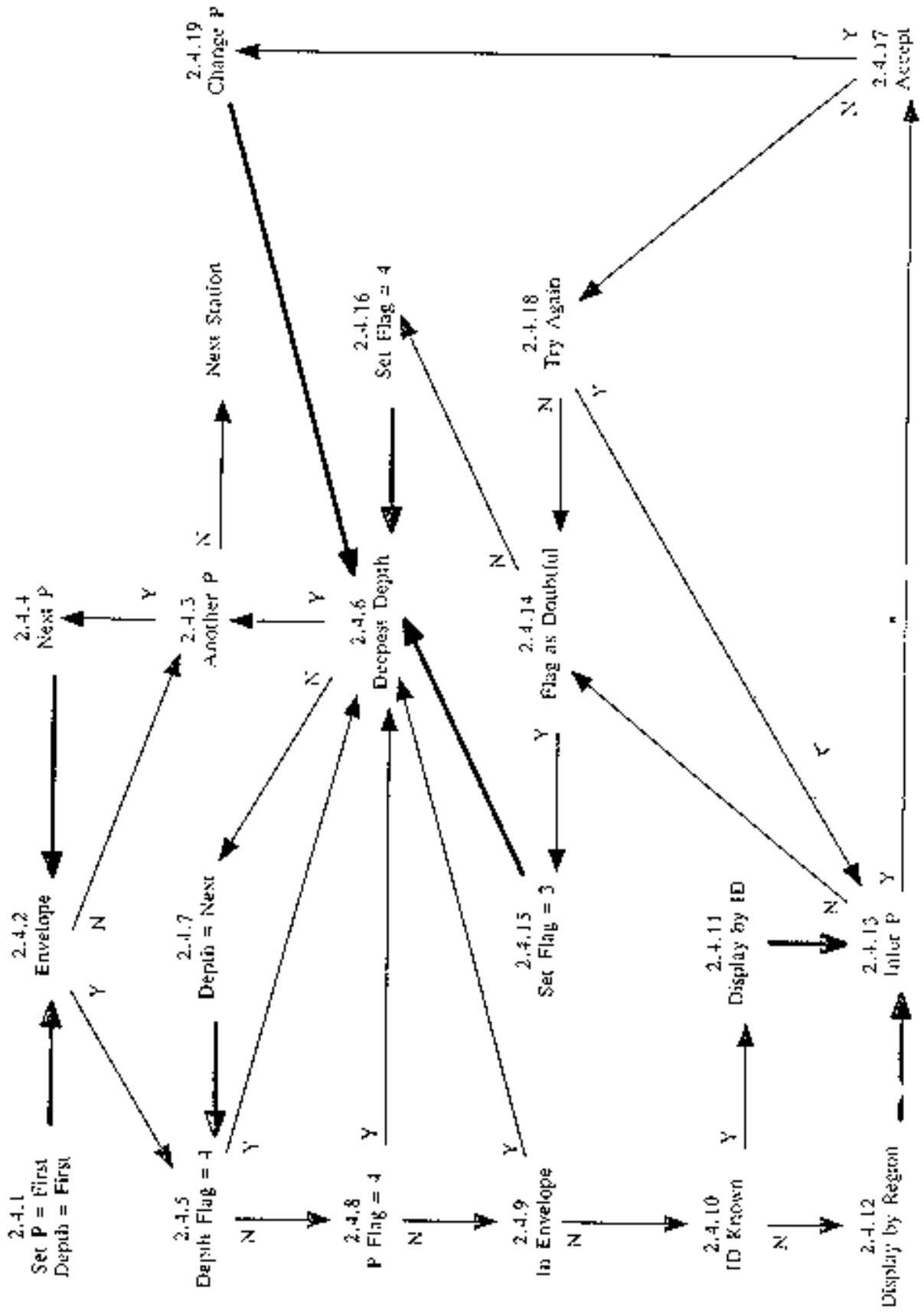

TEST NAME: 2.5 CONSTANT PROFILE

Prerequisites: All of Stage 1 tests.
Global Impossible Parameter Value test.
Profiles sorted by identifier and by increasing date and time for each identifier.
Depths are ordered from shallowest to deepest

Description:

The test is applied in two forms to data received through the IGOSS system. The first applies to those stations that have data digitized at inflection points. If not digitized at inflection points, the second form of the test is applied.

If the data were digitized at inflection points, then there must be observations at more than 2 depths. If not, the next profile is examined. If there are more than two depths, DEPTH1 is set to be the first depth, DEPTH2 the next depth and DEPTH3 the next depth. VALUE1, VALUE2 and VALUE3 are set to be the values of the parameter at the depths just defined. If any of the quality flags at the three depths is set to be erroneous, DEPTH3 is tested to determine if it is the deepest. If so, the next profile is tested. If not, DEPTH1 is set to DEPTH2, DEPTH2 is set to DEPTH3, VALUE1 is set to VALUE2 and VALUE2 is set to VALUE3. DEPTH3 is set to the next depth in the profile and VALUE3 to the value of the parameter at the new DEPTH3. Then the quality flags on the depths are tested as described before.

If none of the quality flags on the three depths is set to be erroneous, the same test is applied to the quality flags on the corresponding three parameter values. If any one is set to be erroneous, DEPTH3 is tested to be the deepest in the profile with subsequent actions described above. If none are set to be erroneous, then the three values are tested to determine if they are all identical. If they are not, DEPTH3 is tested to be deepest in the profile. If they are all the same, the profile identifier is tested to determine if it is known. If known, the entire parameter-depth profile with quality flags is displayed. As well, the parameter values at other stations with the same identifier and in the same depth range as DEPTH2 are displayed. If the identifier is not known, the profile is displayed as described above. As well, the parameter values from other profiles in the neighbourhood of the profile under consideration and in the same depth range as DEPTH2 are displayed. *In either case, the user is then asked if the parameter value at DEPTH2 should be inferred. If so, the user makes the inference and may accept. If accepted, the original value is preserved, the new value substituted, the quality flag on the parameter value at DEPTH2 is set to "5", changed, and then the DEPTH3 is tested to be the deepest in the profile. If no inference is accepted, the user can choose to set the quality flag on the value to be doubtful or erroneous. In either case, the flag is set and DEPTH3 tested to see if it is the deepest in the profile.

If the data were digitized at selected depths, then the profile is examined to determine if there is more than one observation in the profile. If not, the next profile is examined. If there is, DEPTH1 is set to the first depth, DEPTH2 to the next depth, and parameter values, VALUE1 and VALUE2, set to the values of the parameters at DEPTH1 and DEPTH2. If any of the quality flags on the two depths is set to be erroneous, then DEPTH2 is examined to see if it is the deepest in the profile. If it is, a marker is examined to see if it indicates the parameter values are the same at all depths. If not, the next profile is examined. If the marker has been set, that is all values are the same in the profile, then all quality flags on parameter values which are not set to erroneous are set to doubtful, and the next profile examined.

If DEPTH2 is not the deepest in the profile, DEPTH1 is set to DEPTH2, DEPTH2 to the next depth in the profile and the corresponding parameter values are reset. Then the test of the quality flags on the depths is conducted.

If neither of the quality flags on the depths is set to be erroneous, the quality flags on VALUE1 and VALUE2 are examined to see if either is set to be erroneous. If one is, DEPTH2 is tested to be the deepest in the profile, and actions proceed as described above. If neither flag is set to be erroneous, the two values are tested to determine if they are equal. If not, the next profile is tested. If they are, a marker is set, indicating the two parameter values are identical. Then DEPTH2 is tested to see if it is the deepest. The test then proceeds as described above.

History: None

Rules:

- 2.5.1 IF: The data were digitized at inflection points
THEN : 2.5.2
ELSE : 2.5.20
- 2.5.2 IF: There are observations at more than 2 depths in the profile
THEN : 2.5.3
ELSE : Test the next profile
- 2.5.3 : Set DEPTH1 to the first depth in the profile, DEPTH2 to be the next depth and DEPTH3 to be the next depth
: Set VALUE1 to the parameter value at the first depth in the profile, VALUE2 to the parameter value at the next depth and VALUE3 to be the parameter value at the next depth
: 2.5.4
- 2.5.4 IF: Any of DEPTH1, DEPTH2 or DEPTH3 have a quality flag set to erroneous
THEN : 2.5.5
ELSE : 2.5.7
- 2.5.5 IF: DEPTH3 is the deepest in the profile
THEN : Test the next profile
ELSE : 2.5.6
- 2.5.6 : Set DEPTH1 = DEPTH2, DEPTH2 = DEPTH3, DEPTH3 = next depth in the profile
: Set VALUE1 = VALUE2, VALUE2 = VALUE3, VALUE3 = to the parameter value at the next depth in the profile
: 2.5.4
- 2.5.7 IF: Any of VALUE1, VALUE2, VALUE3 have a quality flag set to erroneous
THEN : 2.5.5
ELSE : 2.5.8
- 2.5.8 IF: VALUE1 = VALUE2 = VALUE3
THEN : 2.5.10
ELSE : 2.5.5
- 2.5.10 IF: The profile identifier is known
THEN : 2.5.11
ELSE : 2.5.12
- 2.5.11 : Display the parameter values, depths and quality flags for the entire profile under consideration
: Display the parameter values, depths, flags and observation times for all profiles with the same identifier and in the same depth range as DEPTH2
: 2.5.13
- 2.5.12 : Display the parameter values, depths and quality flags for the entire profile under consideration
: Display the parameter values, depths, flags and observation times for all profiles in the neighbourhood of the profile under consideration and in the same depth range as DEPTH2
: 2.5.13
- 2.5.13 IF: The user chooses to infer a value for VALUE2
THEN : 2.5.14

- ELSE : 2.5.17
- 2.5.14 IF: The user accepts the inferred value
THEN : 2.5.15
ELSE : 2.5.16
- 2.5.15 : Infer the value for VALUE2
: Preserve the original value of the parameter
: Set the new value to be the inferred one
: Set the quality flag on the parameter value to be "5", changed
: 2.5.5
- 2.5.16 IF: The user chooses to flag VALUE2 as doubtful
THEN : 2.5.17
ELSE : 2.5.18
- 2.5.17 : Set the quality flag on VALUE2 to be "3", doubtful
: 2.5.5
- 2.5.18 : Notify the user that the quality flag has been set to erroneous
: Set the quality flag on VALUE2 to be '4', erroneous
: 2.5.5
- 2.5.20 IF: There are observations at more than one depth in the profile
THE : 2.5.21
ELSE : Test the next profile
- 2.5.21 : Set DEPTH1 to the first depth in the profile, DEPTH2 to be the next depth
: Set VALUE1 to the parameter value at the first depth in the profile, VALUE2 to the
parameter value at the next depth
: 2.5.22
- 2.5.22 IF: Any of DEPTH1 or DEPTH2 have a quality flag set to erroneous
THEN : 2.5.23
ELSE : 2.5.25
- 2.5.23 IF: DEPTH2 is the deepest in the profile
THEN : 2.5.28
ELSE : 2.5.24
- 2.5.24 : Set DEPTH1 DEPTH2, and DEPTH2 = the next depth in the profile
: Set VALUE1 VALUE2, VALUE2 = to the parameter value at the next depth in the profile
: 2.5.22
- 2.5.25 IF: Either of VALUE1 or VALUE2 have a quality flag set to erroneous
THEN : 2.5.23
ELSE : 2.5.26
- 2.5.26 IF: VALUE1 = VALUE2
THEN : 2.5.27
ELSE : Test the next profile
- 2.5.27 Set a marker indicating that the last values examined were identical
2.5.23
- 2.5.28 IF: The marker was set indicating the last values were identical
THEN : 2.5.29
ELSE : Test the next profile

2.5.29 : For all of the quality flags on parameter values in the profile which are not set to be erroneous, set them to "3", doubtful
: Test the next profile

2.5 Constant Profile (Part I)

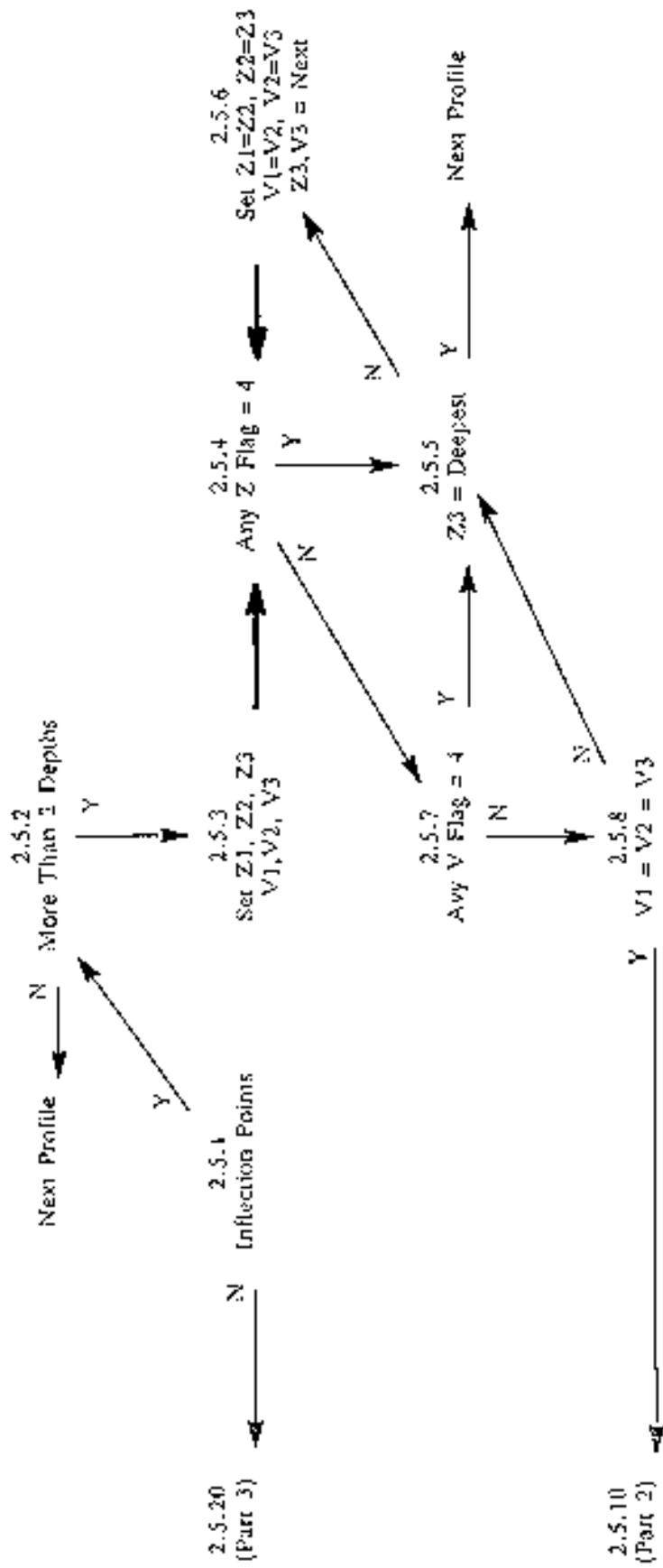

2.5 Constant Profile (Part 2)

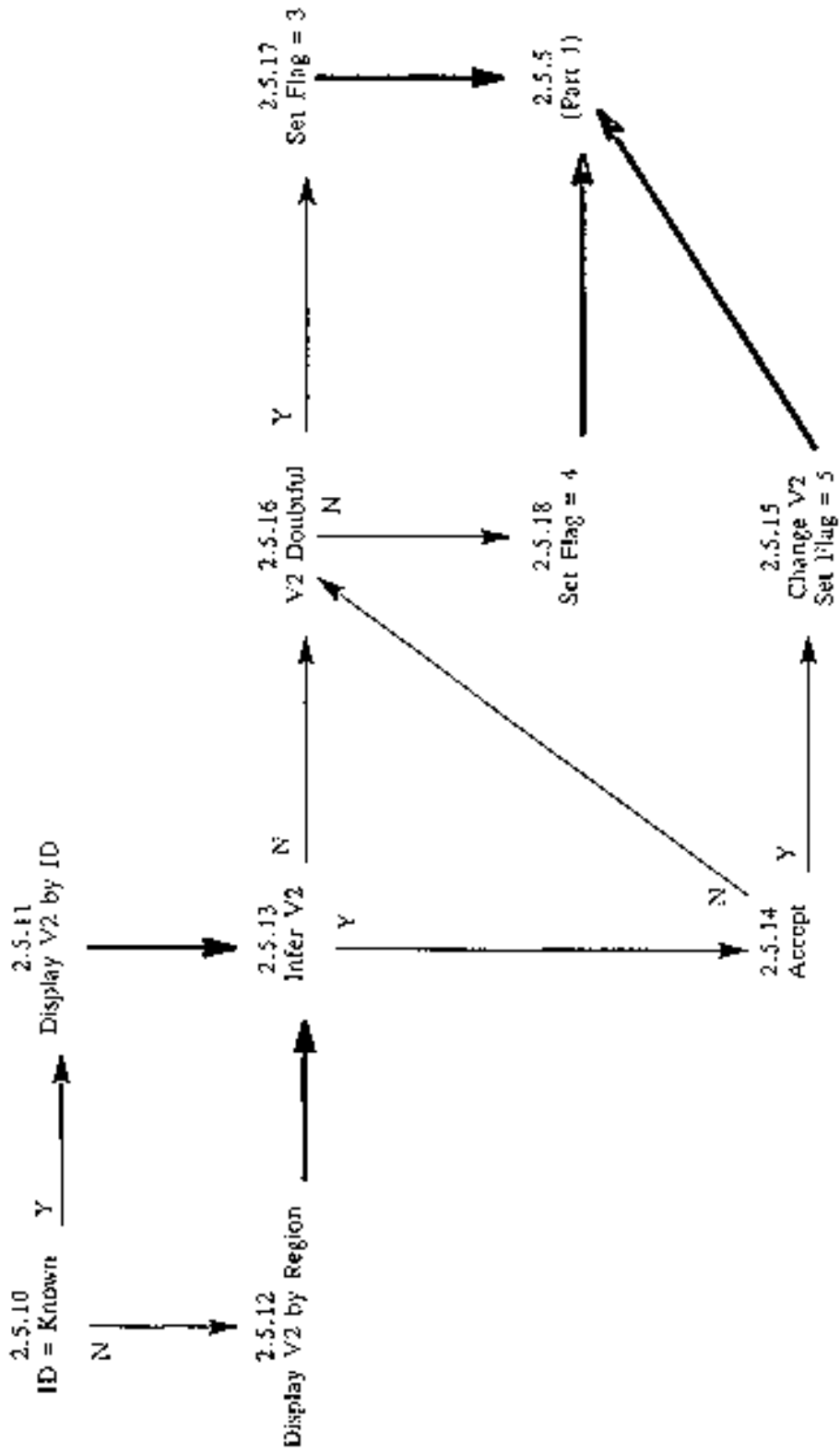

2.5 Constant Profile (Part 3)

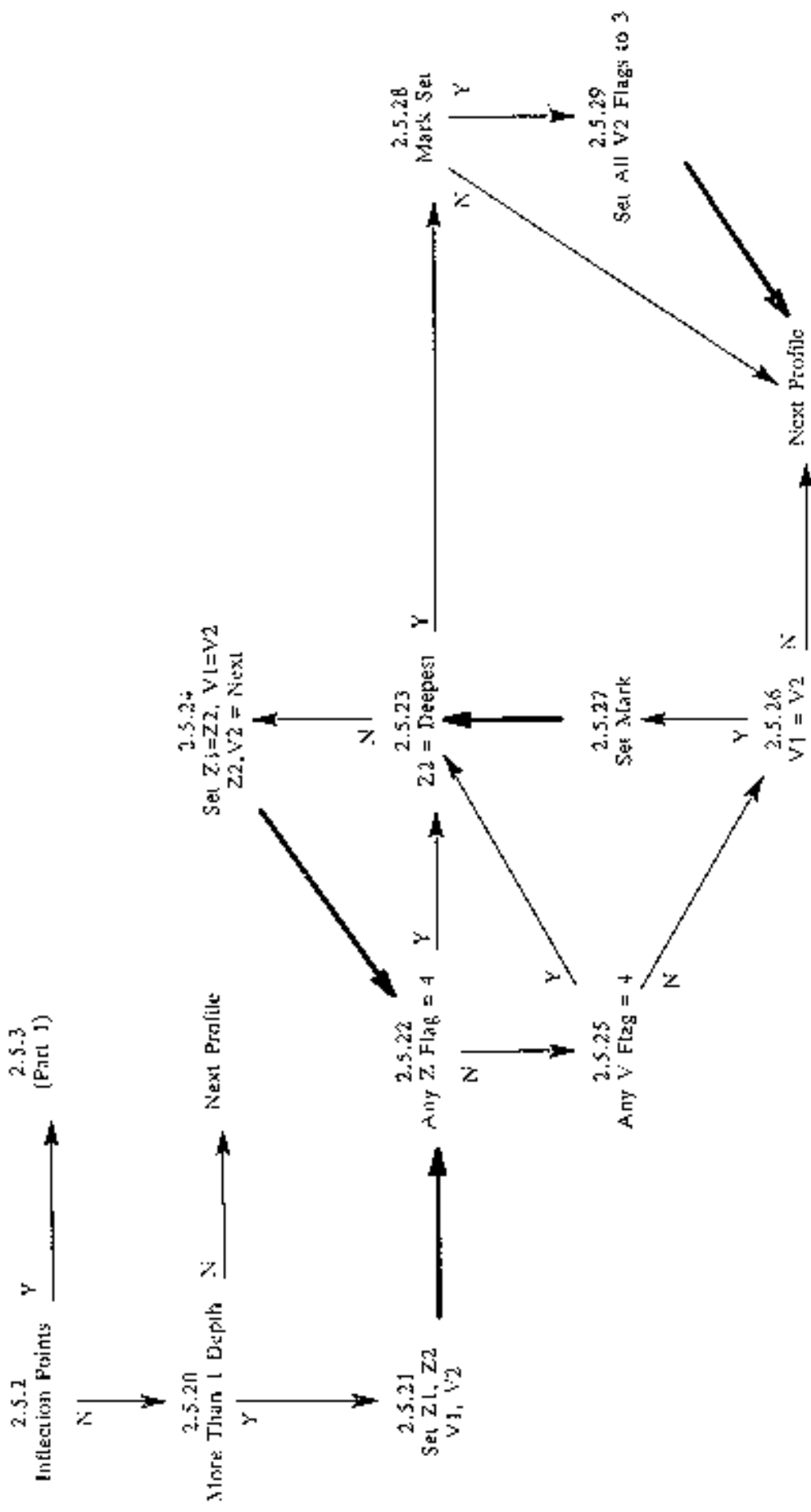

TEST NAME: 2.6 FREEZING POINT TEST

Prerequisites: All of Stage 1 tests.
Global Impossible Parameter Value test.
Sort by profile identifiers and date time in identifier

Description:

This test is the observed temperature at a given depth and salinity is colder than the calculated freezing point temperature. The algorithm for this is described below. It is expressed as a relationship between temperature, salinity and pressure. Conversions of depth to pressure may be made using the algorithm given in the reference below.

The test begins by determining if both temperature and salinity observations at the same pressure exist for the profile. If not, the next station is tested. If so, the PRESSURE is set to the first pressure, and TEMP and SAL set to the temperature and salinity values at PRESSURE. The quality flags on both TEMP and SAL are examined. If either flag is set to be erroneous, the pressure is tested to see if it is the deepest in the profile. If it is, test the next station. If not, set PRESSURE, TEMP and SAL to the values at the next pressure and then test the quality flags on TEMP and SAL.

If the quality flags on both TEMP and SAL are not set to be erroneous, then test the flag on PRESSURE. If it is set to be erroneous, test if the pressure is the deepest in the profile and continue as described above. If the quality flag on the pressure is not set to be erroneous, test if the salinity lies within the range of 27 to 35 PSU. If not, test if the pressure is the deepest. If the salinity is in the range, then calculate the freezing temperature based on the salinity and pressure using the algorithm below. If the observed temperature is greater than or equal to the calculated freezing temperature, then test if the pressure is the deepest in the profile. If the observed temperature is less than the calculated freezing temperature, then test if the profile identifier is known. If known, display the entire temperature and salinity profile, with quality flags. As well, display the temperature and salinity values and quality flags from the same pressure range as that under consideration and at the other profiles with the same identifier. If the identifier is not known, display all of the same information, but this time from profiles in the neighbourhood of the profile under consideration. Then, for either display ask the user if they wish to infer the values for temperature and/or salinity. If so, infer the values, preserve the original and set the quality flag to 5. The inferred value must lie within the permitted Global Impossible Parameter Values. Then, test if the salinity lies within 27 to 35 PSU and proceed as described above.

If the user chooses not to infer values, temperature and /or salinity values may be flagged as doubtful or erroneous. In either case, the appropriate quality flag(s) is set and the pressure is tested to determine if it is the deepest in the profile.

The inferred value is the, calculated freezing temperature.

Algorithm:

$$T = -0.0575*S + 1.71052E-3*S^{3/2} - 2.154996E4*S^{-2} - 7/53E=4*P$$

Where T is the calculated freezing point temperature,
S is the salinity in PSU and must lie between 27 and 35,
P is the pressure level in decibars of the observed salinity

Reference:

UNESCO Technical Papers in Marine Science #44, Algorithms for Computation of Fundamental Properties of Seawater, UNESCO, 1983.

History: None

Rules:

- 2.6.1 IF: There are both temperature and salinity profiles at the station
THEN : 2.6.2
ELSE : Test the next station
- 2.6.2 : Set PRESSURE to be the first pressure in the profile
: Set TEMP and SAL to be the temperature and salinity at PRESSURE
: 2.6.3
- 2.6.3 IF: Either TEMP or SAL has a quality flag set to be erroneous
THEN : 2.6.4
ELSE : 2.6.6
- 2.6.4 IF: PRESSURE is the deepest in the profile
THEN : Test the next station
ELSE : 2.6.5
- 2.6.5 : Set PRESSURE to be the next in the profile
: Set TEMP and SAL to be the temperature and salinity at PRESSURE
: 2.6.3
- 2.6.6 IF: The quality flag on PRESSURE is set to be erroneous
THEN : 2.6.4
ELSE : 2.6.7
- 2.6.7 IF: SAL lies between 27 and 35 PSU
THEN : 2.6.8
ELSE : 2.6.4
- 2.6.8 IF: TEMP is greater than or equal to the calculated freezing point temperature
THEN : 2.6.4
ELSE : 2.6.9
- 2.6.9 IF: The identifier of the station is known
THEN : 2.6.11
ELSE : 2.6.10
- 2.6.10 : Display the profiles of temperature and salinity by pressure with the associated quality flags
: Display the values and flags of the temperature and salinity in the same pressure range as PRESSURE for stations in the neighbourhood of the station under consideration
: 2.6.12
- 2.6.11 : Display the profiles of temperature and salinity by pressure with the associated quality flags
: Display the values and flags of the temperature and salinity in the same pressure range as PRESSURE for stations with the same identifier as the station under consideration
: 2.6.12
- 2.6.12 IF: The user chooses to infer a value for TEMP and /or SAL
THEN : 2.6.13
ELSE : 2.6.14
- 2.6.13 : Infer the value(s) for TEMP and/or SAL
: Preserve the original value(s) of TEMP and/or SAL
: Set the quality flag(s) on TEMP and/or SAL to be "5", changed
: 2.6.7

- 2.6.14 IF: The user chooses to flag TEMP and/or SAL as doubtful
THEN : 2.6.15
ELSE : 2.6.16
- 2.6.15 : Set the quality flag on TEMP and/or SAL to be "3", doubtful : 2.6.4
- 2.6.16 : Notify the user that the quality flag on TEMP has been set to erroneous
: Set the quality flag on TEMP to "4", erroneous
: 2.6.4

2.6 Freezing Point Test

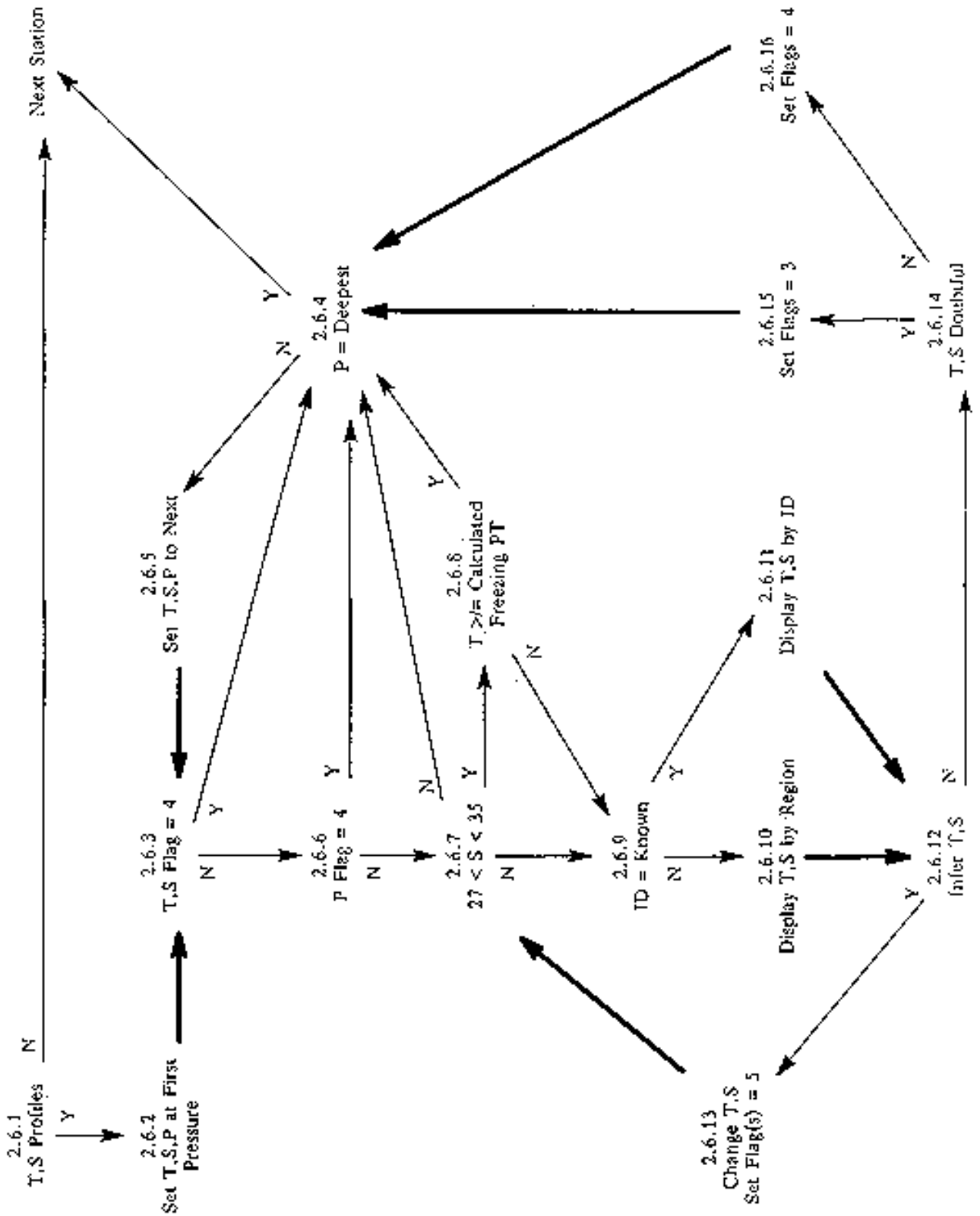

TEST NAME: 2.7 SPIKE TEST

Prerequisites: All of Stage 1 tests.
Global Impossible Parameter Value test.
Sort by profile identifiers and date time in identifier

Description:

This test uses the procedures described in WMO/IOC Manuals and Guides #3 to determine if a value in a profile represents a spike. Note that the threshold value for salinity has been modified.

Algorithm:

If $(|V2 - (V3 + V1)/2| - |V1 - V3|)/2 > V \text{ THRESHOLD}$
Then the V2 exceeds the spike test

Parameter	Threshold
Temperature	2.0 degrees C
Salinity	0.3 PSU

History: None

Rules:

- 2.7.1 IF: There are observations at more than two depths in the profile
THEN : 2.7.2
ELSE : Test the next station
- 2.7.2 : Set DEPTH to be the first depth in the profile, DEPTH2 to be the next depth in the profile and DEPTH3 to be the next depth
: Set VALUE1 to be the value of the parameter at DEPTH1, VALUE2 to be the value of the parameter at DEPTH2 and VALUE3 to be the value of the parameter at DEPTH3
: 2.7.3
- 2.7.3 IF: Any of DEPTH1, DEPTH2 or DEPTH3 have a quality flag set to be erroneous
THEN : 2.7.4
ELSE : 2.7.6
- 2.7.4 IF: DEPTH3 is the deepest in the profile
THEN : Test the next station
ELSE : 2.7.5
- 2.7.5 : Set DEPTH1 to DEPTH2, DEPTH2 TO DEPTH3 and DEPTH3 to be the next in the profile
: Set VALUE1 to VALUE2, VALUE2 to VALUE3 and VALUE3 to be the value of the parameter at DEPTH3
: 2.7.3
- 2.7.6 : IF: The quality flag on VALUE1, VALUE2 or VALUE3 is set to be erroneous
: THEN : 2.7.7
: ELSE : 2.7.9
- 2.7.7 IF: There are any other parameters available for these depths
THEN : 2.7.8
ELSE : 2.7.4
- 2.7.8 : Set VALUE1 VALUE2, VALUE3 to be values of the next parameter at depths DEPTH1, DEPTH2 and DEPTH3

- : 2.7.6
- 2.7.9 IF: The VALUE2 exceeds the spike test described above
 THEN : 2.7.10
 ELSE : 2.7.7
- 2.7.10 IF: The identifier of the station is known
 THEN : 2.7.11
 ELSE : 2.7.12
- 2.7.11 : Display the profiles by depth with the associated quality flags
 : Display VALUE2 and flags of the same parameter in the same depth range as DEPTH2 for
 stations with the same identifier as the station under consideration
 : 2.7.13
- 2.7.12 : Display the profiles by depth with the associated quality flags
 : Display VALUE2 and flags of the same parameter in the same depth range as DEPTH2 for
 stations in the neighbourhood of the station under consideration
 : 2.3.13
- 2.7.13 IF: The user chooses to infer a value for VALUE2
 THEN : 2.7.14
 ELSE ; 2.7.17
- 2.7.14 IF: The user chooses to accept the inferred value
 THEN ; 2.7.15
 ELSE : 2.7.16
- 2.7.15 : Preserve the original value
 : Substitute the new value
 : Set the quality flag(s) on VALUE2 to be "5", changed
- 2.7.7
- 2.7.16 IF: The user chooses to flag VALUE2 as doubtful
 THEN ; 2.7.17
 ELSE : 2.7.18
- 2.7.17 Set the quality flagon VALUE2 to be "3", doubtful
 : 2.7.7
- 2.7.18 : Notify the user that the quality flagon VALUE2 has been set to erroneous
 : Set the quality flag on VALUE2 to "4", erroneous
 : 2.7.7

2.7 Spike Test (Part 1)

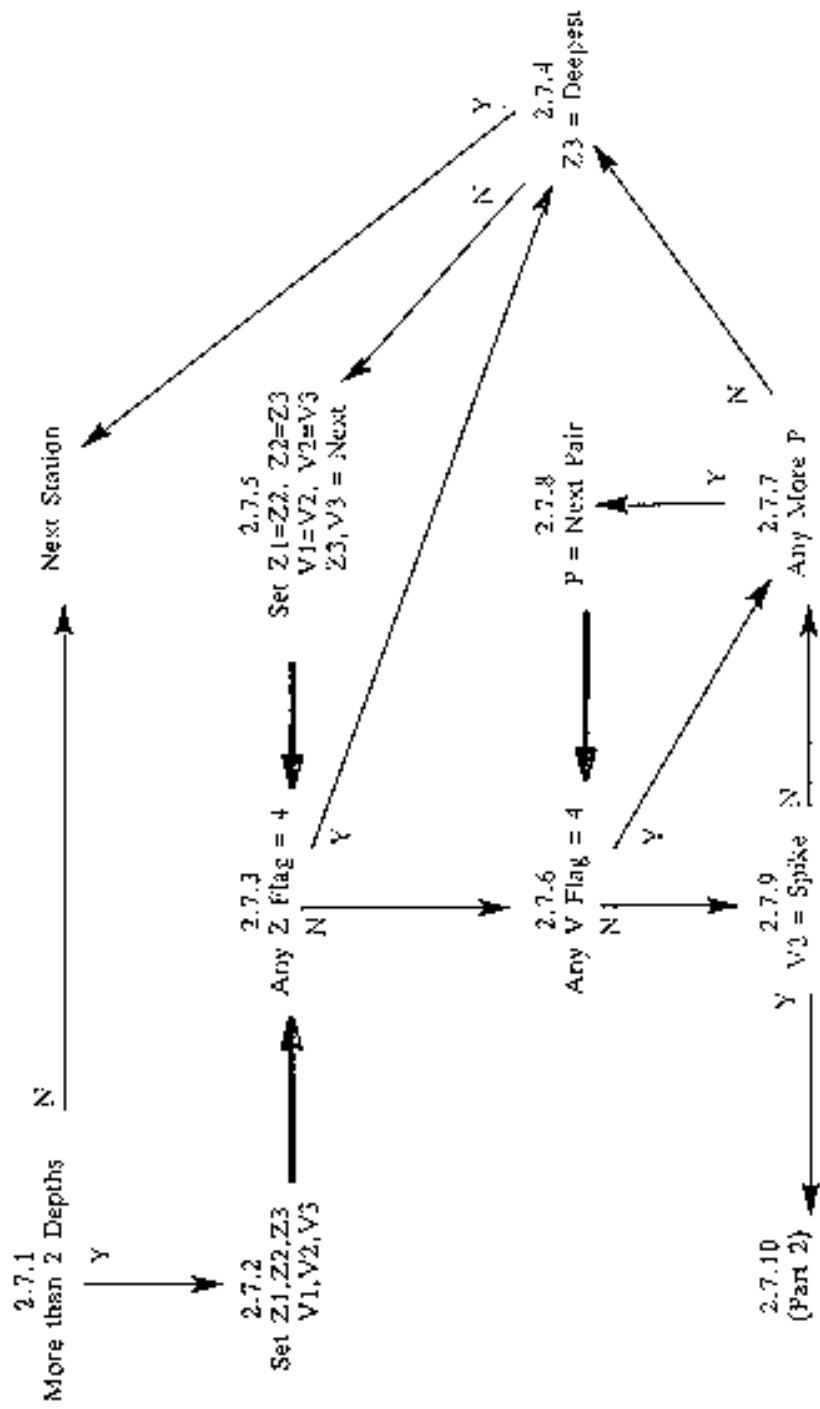

2.7 Spike Test (Part 2)

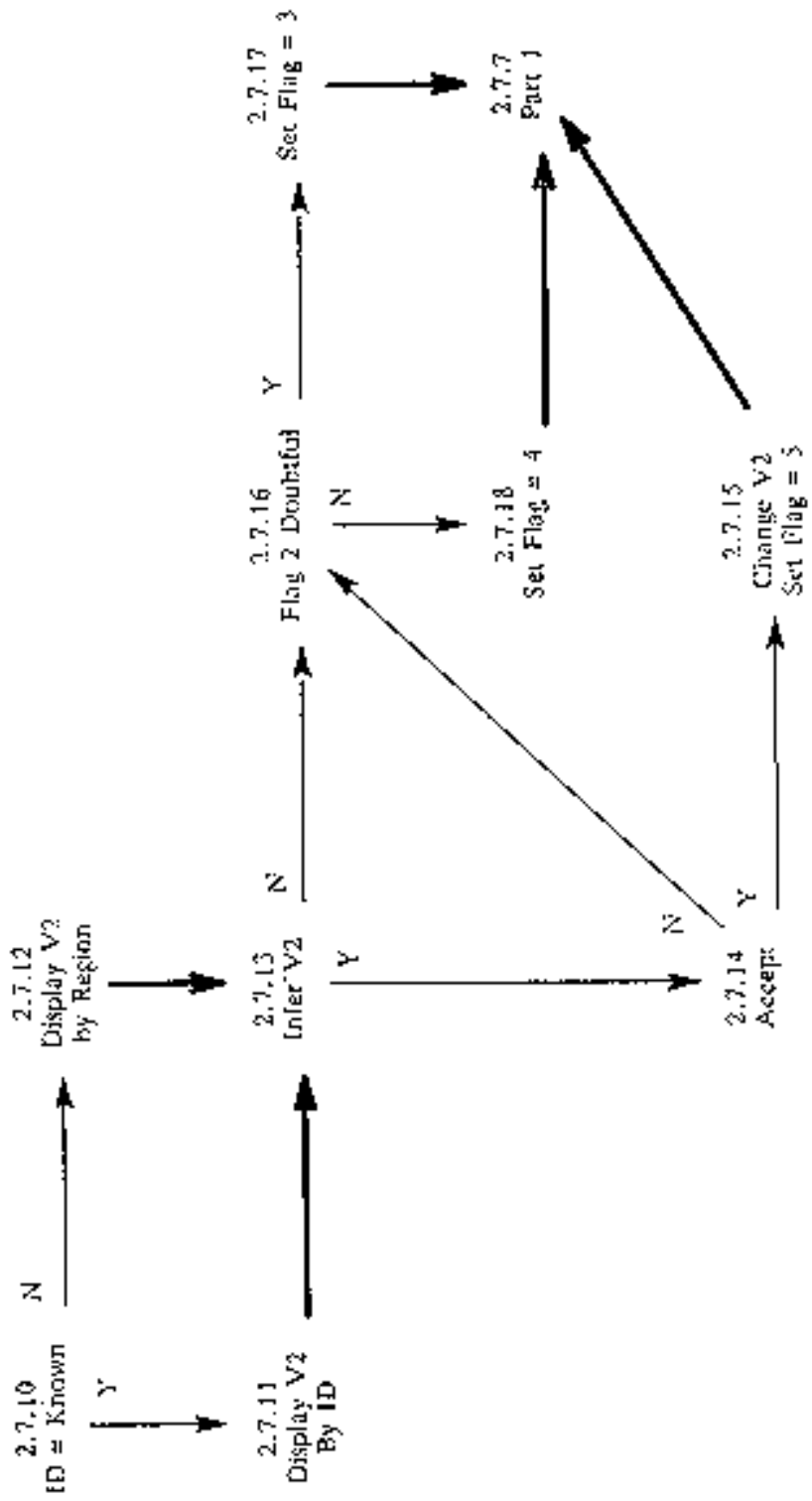

TEST NAME: 2.8 TOP AND BOTTOM SPIKE

Prerequisites: All of Stage 1 tests.
Global Impossible Parameter Value test.
Profiles sorted by identifier and by increasing date and time for each identifier

Description:

This test examines the shallowest and deepest observations to see if there is a spike present. To conduct the test, the depth and parameter values must not be flagged as erroneous. The algorithm to test for a spike is described below.

The test starts by ensuring the profile under consideration has observations at more than one depth. If not, the next station is tested. If there is more than one depth, DEPTH1 is set to the shallowest depth and DEPTH2 to the next depth. VALUE1 and VALUE2 are set to be the values of the first parameter in the station corresponding to DEPTH1 and DEPTH2.

The quality flags on the depths are examined next. If one of them is set to be erroneous, a marker is examined to see if the top spike test was completed. If the marker is not set, DEPTH2 is set to be the deepest depth in the profile, and DEPTH1 to be the next shallower depth. VALUE1 and VALUE2 are set to be the values of the first parameter corresponding to DEPTH1 and DEPTH2. At this time, the marker is set declaring the top spike test was completed. The quality flags on the depths are then tested and action proceeds as described above.

If the marker is set, the station is tested to see if there is another parameter available. If not, the next station is examined. If there is another parameter, depths and values are set as described later and processing continues to check the quality flags on the depths.

If neither of the quality flags on the depths is set to be erroneous, the quality flags on the parameter values under consideration are examined. If either is set to be erroneous, the data are examined to see if there is another parameter observed at the depths under consideration. If not, the marker is set declaring the top spike test is complete. Processing then passes to check this marker and action proceeds as described above. If there are other parameters, VALUE1 and VALUE2 are set to be the parameter values of the next parameter at the depths under consideration. Next the quality flags on the depths are tested and actions continue as described above.

If neither of the parameter values under consideration have a quality flag set to be erroneous, the values are examined to determine if there is a spike at the top or bottom (whichever is being tested at the time). If there is no spike, other parameters at the same depths are looked for and actions proceed as described previously.

If a spike is found, the identifier of the station is examined. If the identifier is known, the entire profile of the parameter at the station is displayed along with the associated quality flags. As well, the parameter values and flags in the same depth range at all other stations with the same identifier are displayed. If the identifier is not known, the same information as just described is displayed but this time the parameter values at all other stations in the neighbourhood of the suspect profile are displayed. In either case, the user can choose to infer a correct value for either the surface value (for the top spike test) or the deepest value (for the bottom spike test).

If the user chooses to infer the value, the results are displayed and, if the user accepts the choice under consideration, the original value is preserved, the new value is inserted and the quality flag on the value set to changed. The new value is then checked to be sure it does not fail the spike test and action proceeds as described before. If the user rejects the inference, they may try another.

If the user chooses not to infer a value, the value may be flagged as doubtful.

If the user chooses to flag the value as doubtful, the quality flag on the value is set to be doubtful and the station is checked to see if there are more parameters at the station. If the user chooses not to flag

the value as doubtful, it is flagged as erroneous, and the station is checked to see if there are more parameters.

Algorithm:

Top Spike

IF $VDN < (V1 - V2) < VUP$

then no spike is detected

Parameter	VDN	VUP
Temperature	-10.0	10.0 degrees C.
Salinity	-5.0	5.0 PSU

Bottom Spike

IF $VDN < (V2 - V1) < VUP$

then no spike is detected

Parameter	VDN	VUP
Temperature	-10.0	10.0 degrees C.
Salinity	-5.0	5.0 PSU

History: None

Rules:

- 2.8.1 IF: There is more than 1 depth in the profile
THEN : 2.8.2
ELSE : Examine the next station

- 2.8.2 : Set P to be the first parameter with associated depths
: Set Z 1 to be the shallowest depth for P
: Set Z2 to be the next shallowest depth for P
: Set VI to be the value of P at Z 1
: Set V2 to be the value of P at Z2
: 2.8.3

- 2.8.3 IF: The quality flags on Z1 or Z2 is set to be erroneous
THEN : 2.8.4
ELSE : 2.8.8

- 2.8.4 IF: A marker is set
THEN : 2.8.6
ELSE : 2.8.5

- 2.8.5 : Set P to be the first parameter with associated depths
: Set Z2 to be the deepest depth for P
: Set Z1 to be the next shallower depth for P
: Set VI to be the value of P at Z1
: Set V2 to be the value of P at Z2
: Set the marker
: 2.8.3

- 2.8.6 IF: There is another parameter at the station
 THEN : 2.8.7
 ELSE : Clear the marker
 : Examine the next station
- 2.8.7 : Set P to be the next
 : Set V1 to be the value of P at Z1
 : Set V2 to be the value of P at Z2
 : 2.8.3
- 2.8.8 IF: The quality flag on the parameter under consideration and observed at Z1 or Z2 has a
 quality flag set to be erroneous
 THEN : 2.8.10
 ELSE : 2.8.9
- 2.8.9 IF: There is a spike in P
 THEN : 2.8. 11
 ELSE : 2.8. 10
- 2.8.10 IF: There is another parameter at the station
 THEN : 2.8.7
 ELSE : Set marker
 : 2.8.4
- 2.8.11 IF: The identifier of the station is known
 THEN : 2.8.12
 ELSE : 2.8.13
- 2.8.12 : Display the platform identifier, position, date and profile of the station under
 consideration
 : Display the parameter values and quality flags at the same depth as the suspect values for
 other stations with the same identifier
 : 2.8.14
- 2.8.13 : Display the platform identifier, position, date and profile of the station under
 consideration
 : Display the parameter values and quality flags at the same depth as the suspect values for
 other stations in the same region
 : 2.8.14
- 2.8.14 IF: The user chooses to infer the value
 THEN : 2.8.18
 ELSE : 2.8.15
- 2.8.15 IF: The user chooses to flag the top or bottom observation as doubtful
 THEN : 2.8.16
 ELSE : 2.8.17
- 2.8.16 : Set the quality flag on the top or bottom observation to be "3", doubtful
 : 2.8.10
- 2.8.17 : Notify the user that the quality flag on the top or bottom observation will be set to "4",
 erroneous
 : Set the quality flag on the top or bottom observation to be "4", erroneous
 : 2.8.10
- 2.8.18 IF: The user chooses to accept an inference
 THEN : 2.8.20

ELSE : 2.8.19

2.8.19 IF: The user chooses to try again
THEN : 2.8.14
ELSE : 2.8.15

2.8.20 : Preserve the original value and depth
: Substitute the inferred value
: Set the quality flag on the new value to be "5", changed
: 2.8.9

2.8 Top and Bottom Test
Part A

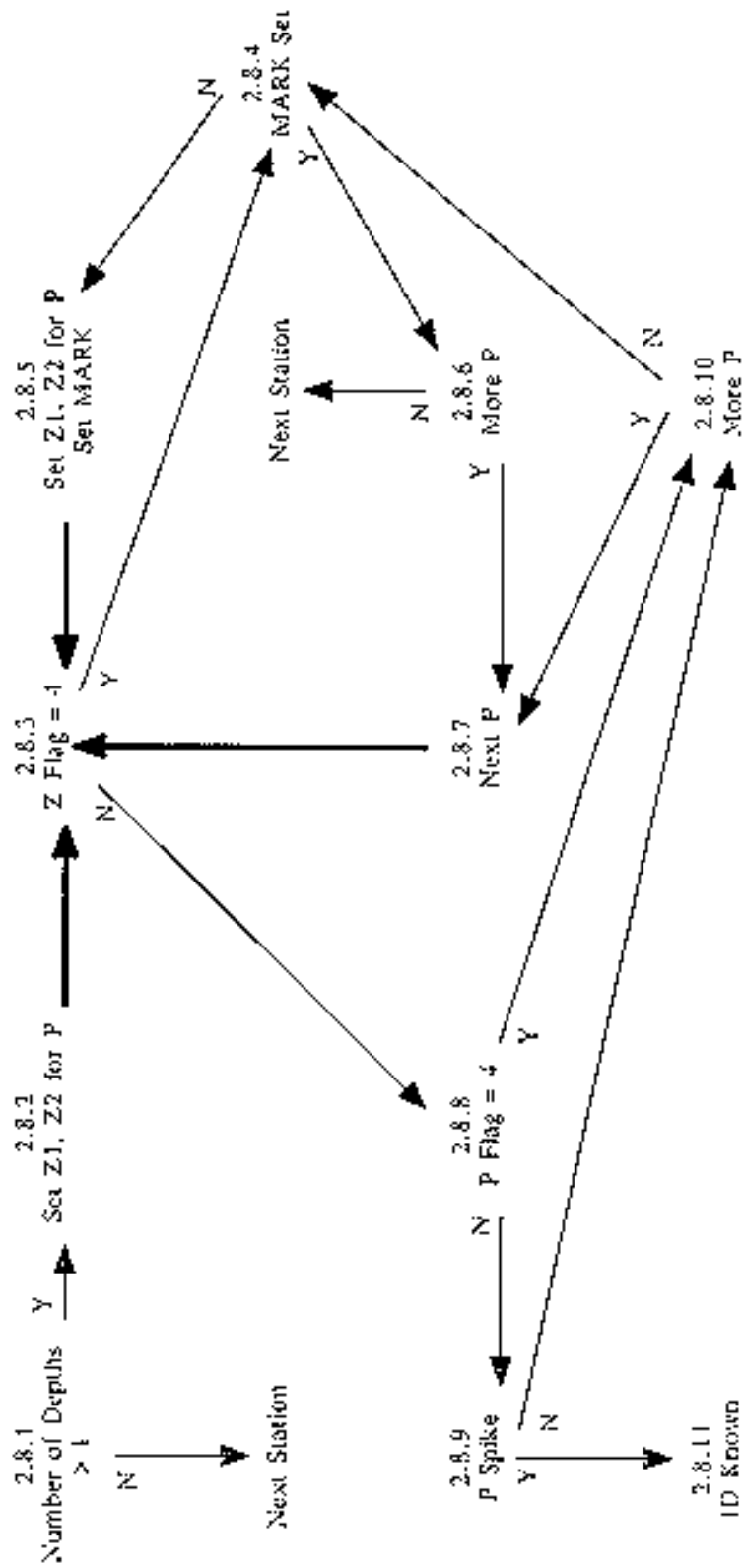

2.8 Top and Bottom Test Part B

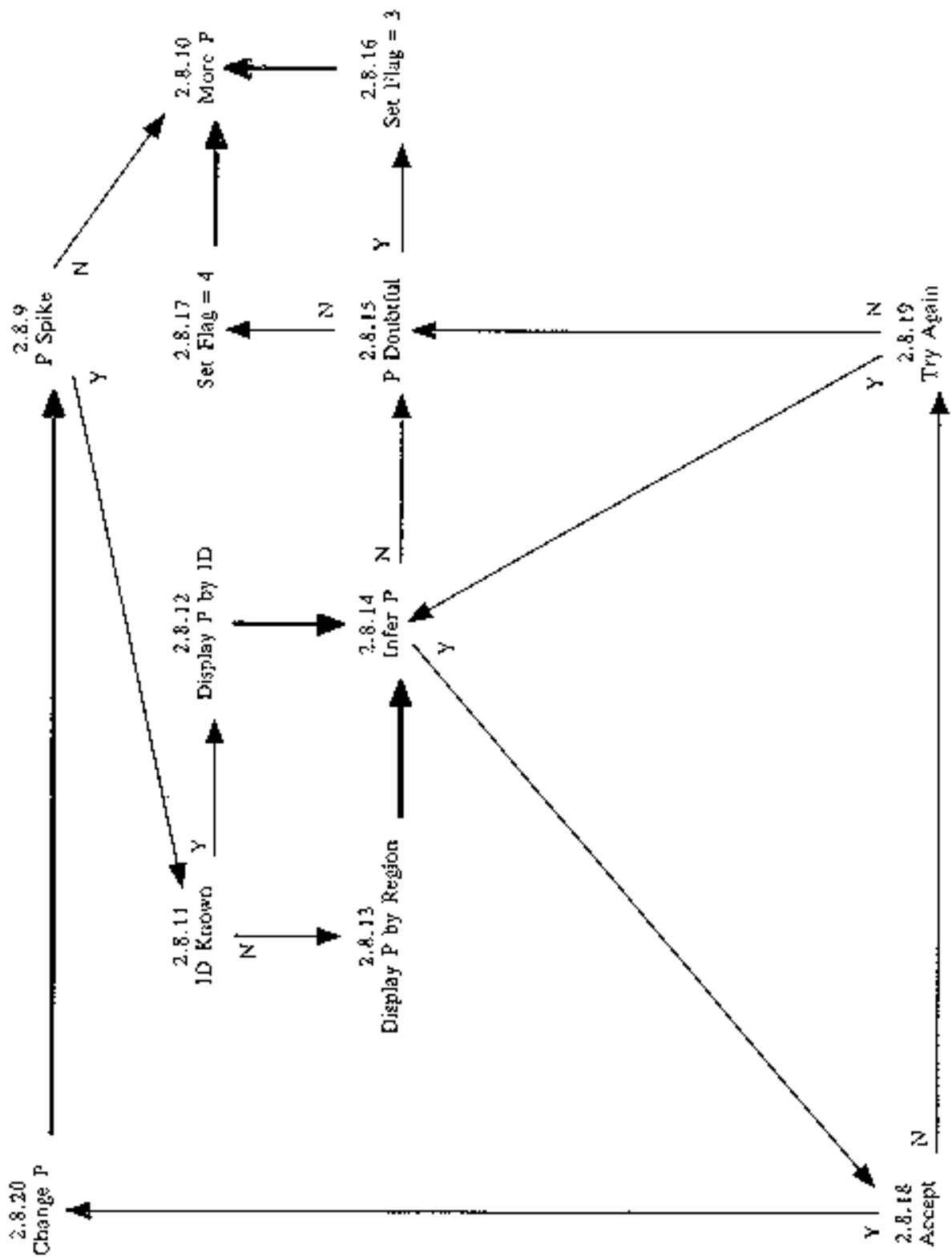

TEST NAME: 2.9 GRADIENT TEST

Prerequisites: All of Stage 1 tests.
Global Impossible Parameter Value test.
Profiles sorted by identifier and by increasing date and time for each identifier

Description:

This test checks that the gradient between two adjacent pairs of points does not exceed a certain threshold given later in table 2.9 below.

The test starts by ensuring the profile under consideration has observations at more than two depths. If not, the next station is tested. If there are more than two depths, DEPTH1 is set to be the first depth, DEPTH2 to be the next depth and DEPTH3 to be the next depth in the profile. VALUE1, VALUE2 and VALUE3 are set to the values of the first parameter at the corresponding depths. Next, the quality flags on the three depths are examined to see if any one is set to be erroneous. If so, DEPTH3 is tested if it is the deepest in the profile. If so, the next station is tested. If DEPTH3 is not the deepest, DEPTH1 is set to DEPTH2, DEPTH2 to DEPTH3 and DEPTH3 to the next depth in the profile. Values for VALUE1, VALUE2 and VALUE3 are set to be those for the first parameter at the corresponding depths. Next the quality flags on the depth are examined and the actions are described above.

If none of the quality flags on the depths are set to be erroneous, the quality flags on the values are examined. If any one of these is set to be erroneous, the station is examined to see if there are other parameters not yet tested at the depths under consideration. If there are no other parameters, DEPTH3 is tested to be the deepest and actions proceed as described before. If there are other parameters, VALUE1, VALUE2 and VALUE3 are set to the values of the next parameter at the depths under consideration. The quality flags on the depths are tested as described above.

If none of the quality flags on the values is set to be erroneous, VALUE2 is tested to see if the gradients between values above and below in the profile are reasonable. If they are, the station is examined to see if there are other parameters not yet tested at the depths under consideration. The resulting actions are described above.

If the gradient test fails, the identifier of the station is examined to determine if it is known. If the identifier is known, the entire profile of the parameter at the station is displayed along with the associated quality flags. As well, the parameter values and flags in the same depth range at all other stations with the same identifier are displayed. If the identifier is not known, the same information as just described is displayed but this time the parameter values at all other stations in the neighbourhood of the suspect profile are displayed. In either case, the user can then choose to infer a correct value for VALUE2.

If the user chooses not to infer a value, they may choose to flag the value as doubtful. If accepted, the quality flag is set to be doubtful and processing checks if there are more parameters at the given depths. If the user chooses not to flag the value as doubtful, it is flagged as erroneous and checks are made if there are more parameters.

If the user chooses to infer a value they are presented with the results.

If the user chooses to accept the inferred value, the original is preserved, the new value is inserted and the quality flag on the value set to changed. The new value is then checked to ensure it passes the gradient test.

Algorithm:

IF ($|V2 - (V1 + V3)/2| > V_GRAD$)

then V2 fails the gradient test

Table 2.9**Parameter V-GRAD**

Temperature 10 degrees C
 Salinity 5 PSU

History: None**Rules:**

- 2.9.1 IF: There are more than 3 depths
 THEN : 2.9.2
 ELSE : Examine the next station
- 2.9.2 : Set P to be the first parameter at the station
 : Set DEPTH1, DEPTH2 and DEPTH3 to be the shallowest depths for P
 :Set VALUE1, VALUE2 and VALUE3 to be the values of the parameters at the three depths
 : 2.9.3
- 2.9.3 IF: Any of the quality flags on the depths are set to be erroneous
 THEN : 2.9.4
 ELSE : 2.9.6
- 2.9.4 IF: DEPTH3 is the deepest depth available at the station
 THEN : Examine the next station
 ELSE
 : 2.9.5
- 2.9.5 : Set P to be the first parameter at the station
 : Set DEPTH1 = DEPTH2, DEPTH2 = DEPTH3 and DEPTH3 to be the next in the profile
 for P
 : Set VALUE1, VALUE2 and VALUE3 to be the values of the parameters at the three depths
 : 2.9.3
- 2.9.6 IF: Any of the quality flags on the values are set to be erroneous
 THEN : 2.9.7
 ELSE : 2.9.9
- 2.9.7 IF: There are other parameters to be examined at the given set of depths
 THEN : 2.9.8
 ELSE : 2.9.4
- 2.9.8 : Set P to be the next parameter at the station
 : Set DEPTH1, DEPTH2 and DEPTH3 to be the shallowest depths for P
 : Set VALUE1, VALUE2 and VALUE3 to be the values of the parameters at the three depths
 : 2.9.3
- 2.9.9 IF: The gradients of the values exceed the permitted thresholds
 THEN : 2.9.10
 ELSE : 2.9.7
- 2.9.10 IF: The identifier of the station is known
 THEN : 2.9.12
 ELSE : 2.9.11
- 2.9.11 : Display the platform identifier, position, date and profile of the station under
 consideration
 : Display the parameter values and quality flags at the same depth as the suspect values for

- other stations in the same region
 - : 2.9.13
- 2.9.12 : Display the platform identifier, position, date and profile of the station under consideration
 - : Display the parameter values and quality flags at the same depth as the suspect values for other stations with the same identifier
 - : 2.9.13
- 2.9.13 IF: The user chooses to infer the value
 - THEN : 2.9.17
 - ELSE : 2.9.14
- 2.9.14 IF: The user chooses to flag VALUE2 as doubtful
 - THEN : 2.9.15
 - ELSE : 2.9.16
- 2.9.15 : Set the quality flag on VALUE2 to be "3", doubtful
 - : 2.9.7
- 2.9.16 : Notify the user that the quality flag on VALUE2 will be set to "4", erroneous
 - : Set the quality flag on VALUE2 to be "4", erroneous
 - ; 2.9.7
- 2.9.17 IF: The user chooses to accept an inference
 - THEN : 2.9.19
 - ELSE : 2.9.18
- 2.9.18 IF: The user chooses to examine another inference
 - THEN : 2.9.13
 - ELSE : 2.9.14
- 2.9.19 : Preserve the original value and depth
 - : Substitute the inferred value
 - : Set the quality flag on the new value to be "5", changed
 - : 2.9.9

2.9 Gradient Test

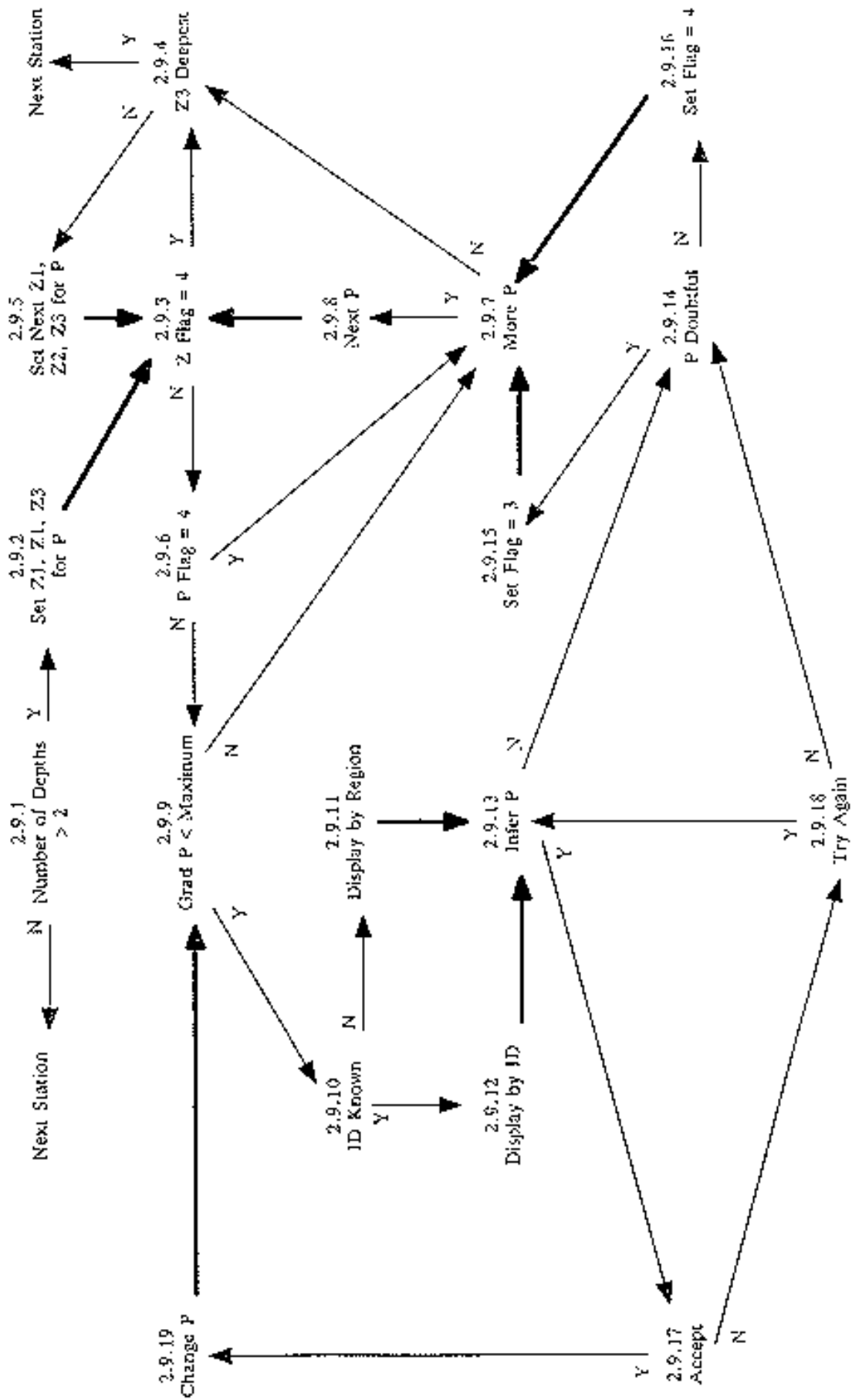

TEST NAME: 2.10 DENSITY INVERSION TEST

Prerequisites: All of Stage 1 tests.
Global Impossible Parameter Value test.
Profiles sorted by identifier and by increasing date and time for each identifier

Description:

This test checks that there is no density inversion as depth increases.

The test starts by ensuring the profile under consideration has observations at more than one depth. If not, the next station is tested. If there is more than one depth, DEPTH1 is set to be the first depth, and DEPTH2 to be the next depth. The quality flags on the depths are examined to see if any one is set to be erroneous. If so, DEPTH2 is tested if it is the deepest in the profile. If so, the next station is tested. If DEPTH2 is not the deepest, DEPTH1 is set to DEPTH2, and DEPTH2 to the next depth in the profile.

If none of the quality flags on the depths are set to be erroneous, the profile is tested to ensure that both a temperature and a salinity are present. If not, the depth is tested to determine if it is the deepest. If both present, the quality flags on the temperature and salinity values are examined. If any one of these is set to be erroneous, the station is examined to see if DEPTH2 is the deepest depth and processing proceeds as already described.

If none of the quality flags on the values is set to be erroneous, the density is calculated at DEPTH1 and DEPTH2 and compared. If the density at DEPTH2 is greater than or equal to that at DEPTH1, DEPTH2 is tested to see if it is the deepest in the profile.

If the density at the deeper depth is less than that at the shallower depth, the identifier of the station is examined to determine if it is known. If the identifier is known, the temperature, salinity and density profiles at the station are displayed along with the associated quality flags. As well, the same variables and flags in the same depth range at all other stations with the same identifier are displayed. If the identifier is not known, the same information as just described is displayed but this time the parameter values at all other stations in the neighbourhood of the suspect profile are displayed. In either case, the user can then choose to infer a correct value for VALUE2.

If the user chooses not to infer a value, they may choose to flag the value as doubtful. If accepted, the quality flag is set to be doubtful and processing checks if there are more parameters at the given depths. If the user chooses not to flag the value as doubtful, it is flagged as erroneous and DEPTH2 then checked to determine if it the deepest in the profile.

If the user chooses to infer a value, the user is presented with the results.

If the user chooses to accept the inferred value, the original is preserved, the new value is inserted and the quality flag on the value set to changed. The new value is then checked to ensure it passes the density inversion test.

History: None

Rules:

- 2.10.1 IF: There are more than 1 depth
THEN : 2.10.2
ELSE : Examine the next station
- 2.10.2 : Set DEPTH1, and DEPTH2 to be the shallowest depths
: 2.10.3
- 2.10.3 IF: Any of the quality flags on the depths are set to be erroneous
THEN : 2.10.4

ELSE : 2.10.6

2.10.4 IF: DEPTH2 is the deepest depth available at the station
 THEN : Examine the next station
 ELSE : 2.10.5

2.10.5 : Set DEPTH] = DEPTH2, and DEPTH2 to be the next depth
 : 2.10.3

2.10.6 IF: Both a temperature and salinity observation are present at DEPTH1 and DEPTH2
 THEN : 2.10.7
 ELSE : 2.10.4

2.10.7 IF: Any of the quality flags on the temperatures or salinities are set to be erroneous
 THEN : 2.10.4
 ELSE : 2.10.8

2.10.8 IF: The calculated density at DEPTH2 is less than that at DEPTH1
 THEN : 2.10.9
 ELSE : 2.10.4

2.10.9 IF: The identifier of the station is known
 THEN : 2.10.11
 ELSE : 2.10.10

2.10.10 : Display the platform identifier, position, date and profile of the station under
 consideration
 : Display the parameter values and quality flags at the same depth as the suspect values for
 other stations in the same region
 : 2.10.12

2.10.11 : Display the platform identifier, position, date and profile of the station under
 consideration
 : Display the parameter values and quality flags at the same depth as the suspect values for
 other stations with the same identifier
 : 2.10.12

2.10.12 IF: The user chooses to infer the values of the temperature and salinity at DEPTH2
 THEN : 2.10.16
 ELSE : 2.10.13

2.10.13 IF: The user chooses to flag the temperature and/or salinity at DEPTH2 as doubtful
 THEN : 2.10.14
 ELSE : 2.10.15

2.10.14 : Set the quality flag on the temperature and/or salinity to be "3", doubtful
 : 2.10.4

2.10.15 : Set the quality flag on the temperature and/or salinity to be "4", erroneous
 : 2.10.4

2.10.16 IF: The user chooses to accept an inference
 THEN : 2.10.18
 ELSE : 2.10.17

2.10.17 IF: The user chooses to examine another inference
 THEN : 2.10.12
 ELSE : 2.10.13

2.10.18 : Preserve the original value and depth
: Substitute the inferred value
: Set the quality flag on the new value to be "5", changed
: 2.10.4

2.10 Density Inversion

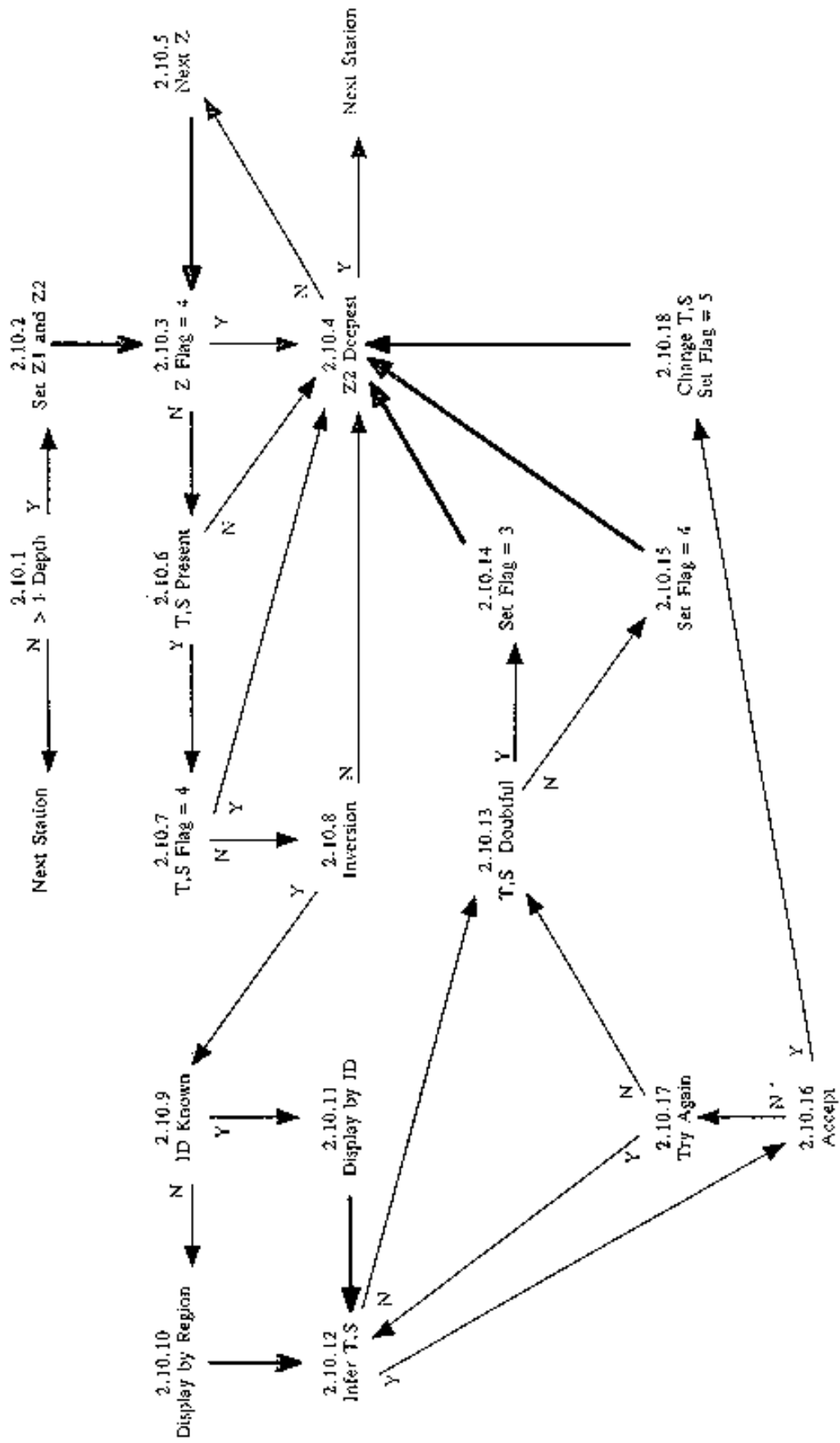

TEST NAME: 3.1 LEVITUS SEASONAL STATISTICS

Prerequisites: All of Stage 1 tests.
Global Impossible Parameter Value test.
Profiles should be sorted by latitude and longitude.

Description:

This test determines if the temperature and salinity observations lie within certain ranges of the mean value given by the Levitus Seasonal Statistics Atlas. If the profile lies close to land and the depth is less than 50 metres, the observed value should lie within 5 standard deviations of the mean value. For all other locations the observed value should lie within 3 standard deviations.

The test begins by checking that the quality flags on neither the latitude nor the longitude are set to be erroneous. If they are the next station is tested. If not, the test starts by setting the first depth under consideration to be the shallowest in the profile. The station is tested to determine if there is a temperature value at the depth in question. If there is not, the station is tested to see if there is a salinity observation. If there is no salinity, the depth is tested to determine if it is the deepest available in the profile. If it is, the next station is tested. If the depth is not the deepest, the next depth is examined and a marker is cleared. This marker is used to indicate that the last variable tested was salinity. Again the station is tested to determine if there is a temperature at the new depth.

If there is a temperature observation at the depth, the parameter value is set to the observed temperature and the quality flag on the depth is tested. If the quality flag is set to be erroneous, the climatology test cannot be applied and so the depth is checked if it is the deepest. Processing from this stop proceeds as already described.

If the quality flag on the depth is not set to be erroneous, then the quality flag on the parameter under consideration is checked. If this is set to be erroneous, the marker (described above) is examined. If this marker has been set, the depth is examined to determine if it is the deepest in the profile. If the marker has not been set, the station is tested to see if there exists a salinity observation at the depth under consideration. If there is not, the depth is tested to see if it is the deepest in the profile.

If there is a salinity observation, the parameter value is set to be the observed salinity and the marker is set. Next the quality flag on the depth is tested and processing proceeds as previously described.

If the parameter flag is not set to be erroneous, the location is tested to be within 1000 kilometers (this distance is defined by the way the mean values were calculated in the Levitus atlas) of land. If it is, the depth is tested to see if it is less than 50 metres. If this is also true, the parameter value is tested to see if it lies within 5 standard deviations of the climatological mean at the station position and the given depth. If so, the marker is checked and action proceeds as described before. If the observation exceeds the range, the parameter values are displayed and processing continues as described later.

If the observation is not within 1000 kilometers of land or if it is not less than 50 metres, then the parameter value is tested to see if it lies within 3 standard deviations of the climatological mean at the station position and the given depth. If this is true, the marker is checked and processing proceeds as already described.

If the parameter value is outside of the prescribed limits, the parameter profile is displayed along with the climatological mean and the appropriate standard deviation limit at the same location. Parameter values at neighbouring stations within the same depth range are also displayed. The user may then choose to set the quality flag on the parameter at the depth to be inconsistent. If the flag is not already set to be inconsistent, the user must confirm the change of the flag. If not confirmed, no action is taken. If confirmed, the quality flag is changed to inconsistent. If the user chooses not to set the flag to be inconsistent, it is set to be doubtful. No matter what action is performed against the quality flag, afterwards the marker is checked and processing continues as already described above.

History: None

Rules:

- 3.1.1 IF: Any one of the latitude or longitude has a quality flag set to be erroneous
THEN : Test the next station
ELSE : 3.1.2
- 3.1.2 : Set DEPTH to be the shallowest depth in the profile
: Set VALUE to be the value of the temperature observation at DEPTH
: 3.1.3
- 3.1.3 IF: There is a temperature observation at DEPTH
THEN : 3.1.8
ELSE : 3.1.4
- 3.1.4 IF: There is a salinity observation at DEPTH
THEN : 3.1.6
ELSE : 3.1.5
- 3.1.5 IF: DEPTH is the deepest in the profile
THEN : Test the next station
ELSE : 3.1.7
- 3.1.6 : Set the parameter value, VALUE, to be the observed salinity at DEPTH
: Set MARK to indicate that salinity is the parameter under consideration
: 3.1.9
- 3.1.7 : Set DEPTH to be the next deeper depth in the profile
: Clear MARK
: 3.1.3
- 3.1.8 : Set the parameter value, VALUE, to be the observed temperature at DEPTH
: 3.1.9
- 3.1.9 IF: The quality flag on DEPTH is set to be erroneous
THEN : 3.1.5
ELSE : 3.1.10
- 3.1.10 IF: The quality flag on VALUE is set to be erroneous
THEN : 3.1.11
ELSE : 3.1.12
- 3.1.11 IF: MARK is set
THEN : 3.1.5
ELSE : 3.1.4
- 3.1.12 IF: The station is within 1000 km of the coast
THEN : 3.1.13
ELSE : 3.1.14
- 3.1.13 IF: DEPTH is less than 50 meters
THEN : 3.1.15
ELSE : 3.1.14
- 3.1.14 IF: VALUE lies within 3 standard deviations of the climatological mean in the depth range of DEPTH and at the same location as the station
THEN : 3.1.11
ELSE : 3.1.16

- 3.1.15 IF: VALUE lies within 5 standard deviations of the climatological mean in the depth range of DEPTH and at the same location as the station
THEN : 3.1.11
ELSE : 3.1.16
- 3.1.16 : Display the parameter profile in question
: Display the climatological mean and 3 or 5 standard deviations as appropriate
: Display parameter values in the same depth range for neighbouring stations
: 3.1.17
- 3.1.17 IF: The user chooses to flag VALUE as inconsistent
THEN : 3.1.18
ELSE : 3.1.21
- 3.1.18 IF: The quality flag on VALUE is already set to be inconsistent
THEN : 3.1.11
ELSE : 3.1.19
- 3.1.19 IF: The user confirms to change the quality flag from doubtful to inconsistent
THEN : 3.1.20
ELSE : 3.1.11
- 3.1.20 : Set the quality flag on VALUE at DEPTH to "2", inconsistent
: 3.1.11
- 3.1.21 : Notify the user that the quality flag on VALUE will be set to doubtful
: Set the quality flag on VALUE at DEPTH to "3", doubtful
: 3.1.11

3.1 Levitus Seasonal Statistics
Part A

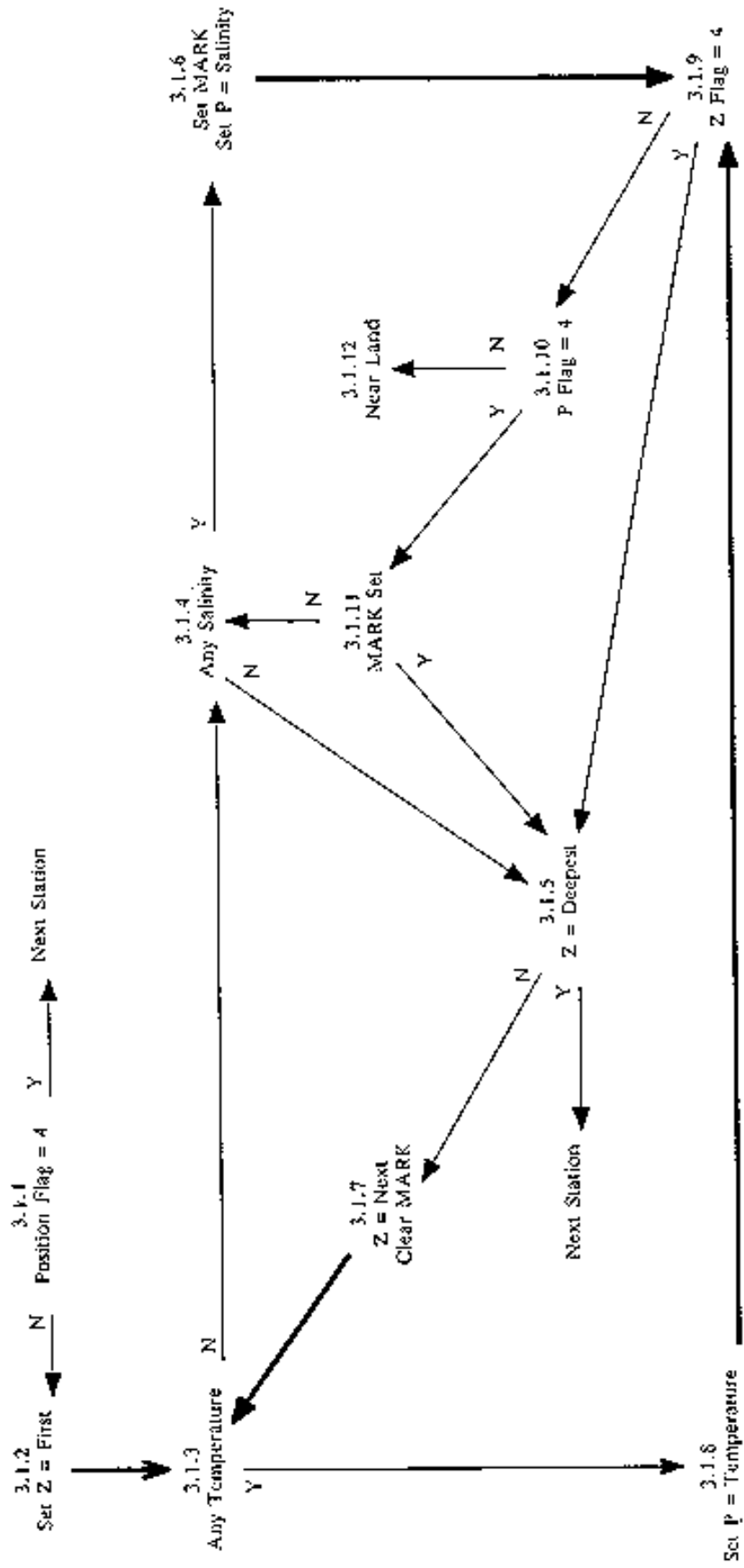

3.1 Levitus Seasonal Statistics
Part B

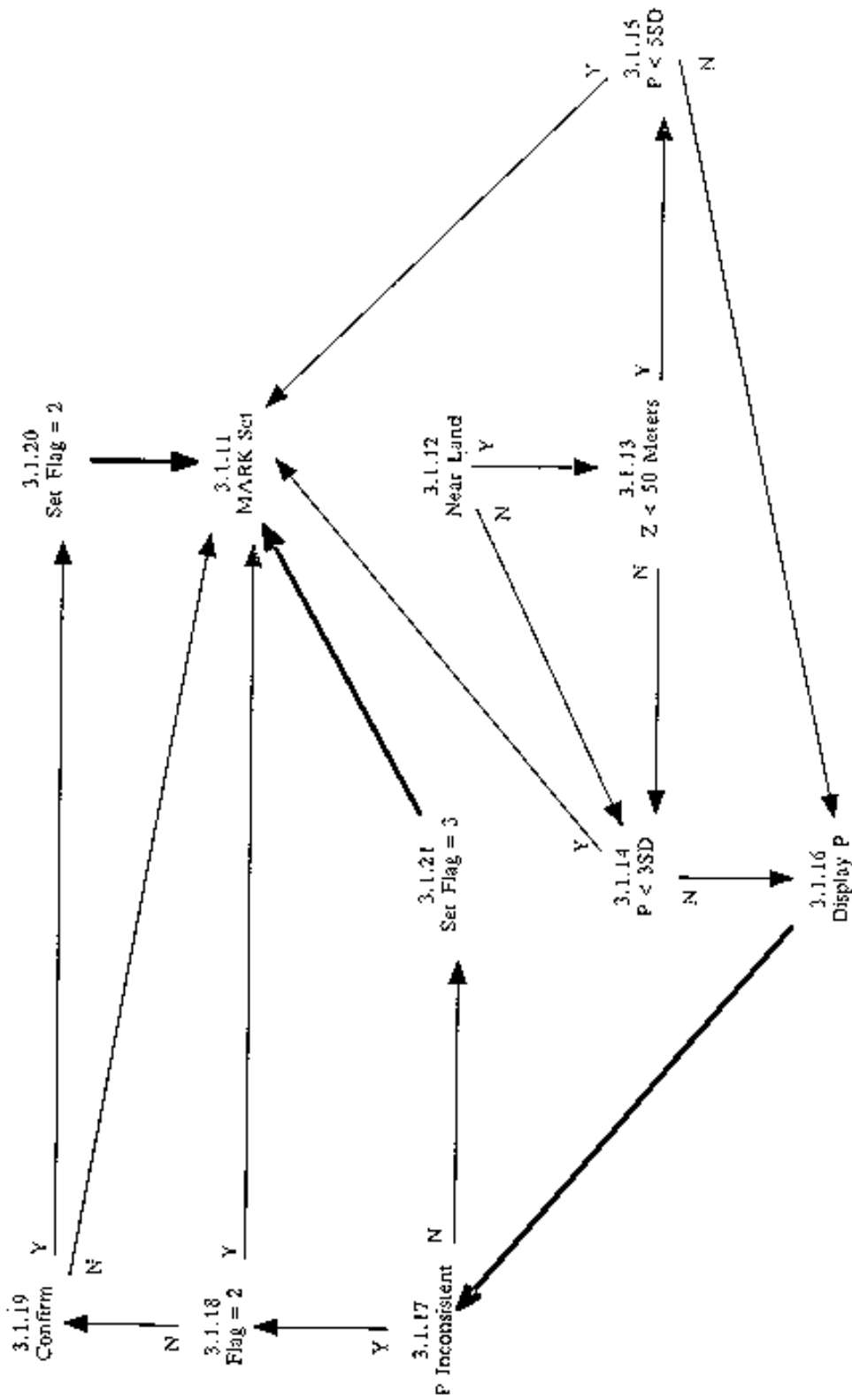

TEST NAME: 3.2 EMERY AND DEWAR CLIMATOLOGY

Prerequisites: All of Stage 1 tests.
Global Impossible Parameter Value test.

Profiles are sorted by latitude and longitude within the region covered by the atlas. This is 10 degrees south to 60 degrees north latitude for both the Atlantic and Pacific oceans. The Atlantic ocean stretches from 0 degrees west to 80 degrees west longitude. The Pacific Ocean extends from 80 degrees west to 120 degrees east longitude.

Description:

This test uses the Emery and Dewar climatology to test if the observed temperatures and salinities lie within 3 standard deviations of the climatological mean. It also tests if a salinity at a given temperature lies within 3 standard deviations of the climatological salinity at the given temperature.

The test begins by ensuring that neither the latitude nor longitude has a quality flag set to be erroneous. If one is set, the next station is tested. If both are fine, the depth is set to be the shallowest in the profile and the quality flag is tested. If it is set to be erroneous, the testing proceeds to Part 3.

If the quality flag on the depth is not set to be erroneous, but there is no temperature observation at the depth, testing proceeds to Part 2. If there is a temperature, but the quality flag is set to be erroneous, processing passes to Part 2. If the quality flag is not set to be erroneous, the temperature is tested to be within 3 standard deviations of the climatological mean at the given depth. If the observation lies within this limit, testing proceeds to Part 2.

If the temperature lies beyond 3 standard deviations from the mean, the temperature profile is displayed. The climatological temperature profile and 3 standard deviations is also displayed. As well, temperature values in the same depth range from neighbouring stations are displayed. The user may then choose to flag the temperature as inconsistent. If he chooses not to do so, the quality flag on the temperature is set to be doubtful and testing proceeds to Part 2.

If the user chooses to flag the temperature as inconsistent, but it has a quality flag assigned as doubtful, the user must confirm the decision. If confirmed, the flag is changed from doubtful to inconsistent. If not confirmed, the flag remains as doubtful. If the flag was not already set to be doubtful, the flag is set to be inconsistent as chosen by the user. In any case, the testing then proceeds to Part 2.

Part 2 of the test checks if there is a salinity observation at the depth under consideration. If not, the depth is checked to see if it is the deepest in the profile. If it is, testing proceeds to the next station. If it is not, the depth is set to be the next deeper in the profile and the quality flag on the depth tested. Actions proceed as described before.

If there is a salinity but its quality flag is set to be erroneous, the depth is tested to determine if it is the deepest in the profile. Testing from this point proceeds as already described above. If the quality flag on the salinity is not set to be erroneous, the value is tested to lie within 3 standard deviations of the climatological mean at the depth under consideration. The treatment of salinity is the same as previously described for temperature. After the quality flag has been set, testing proceeds to Part 3.

Part 3 begins by testing if either the temperature or the salinity has a quality flag set to be erroneous. If so, the depth is tested to determine if it is the deepest in the profile and actions proceed as already described. If both values are fine, the salinity value is tested to lie within 3 standard deviations of the climatological mean salinity at the given temperature. If it does, the depth is tested to determine if it is the deepest, and so on. If it lies outside of 3 standard deviations, the temperature-salinity curve is displayed for the station. At the same time, the climatological T-S curve and 3 standard deviations of salinity from the mean is displayed. Finally, temperature and salinity values in the same depth range but at neighbouring stations are displayed. The user may then choose to set the quality flags on the temperature and/or salinity. Processing proceeds as described before. After the flags are set, the depth is tested to determine if it is the deepest in the profile. Subsequent actions have already been described.

History: None

Rules:

- 3.2.1 IF: Any one of latitude, or longitude has a quality flag set to, be erroneous
THEN : Test the next station
ELSE : 3.2.2
- 3.2.2 : Set DEPTH to be the shallowest depth in the profile
: 3.2.3
- 3.2.3 IF: The quality flag on DEPTH is set to be erroneous
THEN : 3.2.24
ELSE : 3.2.4
- 3.2.4 IF: There is a temperature observation at DEPTH
THEN : 3.2.5
ELSE : 3.2.13
- 3.2.5 IF: The quality flag on temperature is set to be erroneous
THEN : 3.2.13
ELSE : 3.2.6
- 3.2.6 IF: The temperature value lies within 3 standard deviations of the climatological mean at the
given depth for the given station location
THEN : 3.2.13
ELSE : 3.2.7
- 3.2.7 : Display the entire temperature profile with quality flags
: Display the climatological mean and 3 standard deviations
: Display temperature and quality flags in the same depth range from neighbouring stations
: 3.2.8
- 3.2.8 IF: The user chooses to set the quality flag on the temperature to be inconsistent
THEN : 3.2.10
ELSE : 3.2.9
- 3.2.9 : Notify the user that the quality flag on the temperature will be set to doubtful
: Set the quality flag on the temperature to "3", doubtful
: 3.2.13
- 3.2.10 IF: The quality flag on temperature is already set to be doubtful
THEN : 3.2.11
ELSE : 3.2.12
- 3.2.11 IF: The user confirms that the quality flag on temperature should be changed from doubtful to
inconsistent
THEN : 3.2.12
ELSE : 3.2.13
- 3.2.12 : Set the quality flag on the temperature to "2", inconsistent
: 3.2.13
- 3.2.13 IF: There is a salinity observation at DEPTH
THEN : 3.2.16
ELSE : 3.2.14

- 3.2.14 IF: Depth is the deepest in the profile
THEN : Test the next station
ELSE : 3.2.15
- 3.2.15 : Set DEPTH to be the next in the profile
: 3.2.3
- 3.2.16 IF: The quality flag on salinity is set to be erroneous
THEN : 3.2.14
ELSE : 3.2.17
- 3.2.17 IF: The salinity observation lies within 3 standard deviations of the climatological mean at the
given depth and location
THEN : 3.2.24
ELSE : 3.2.18
- 3.2.18 : Display the entire salinity profile with quality flags
: Display the climatological mean and 3 standard deviations
: Display salinity and quality flags in the same depth range from neighbouring stations
: 3.2.19
- 3.2.19 IF: The user chooses to set the quality flag on salinity to be inconsistent
THEN : 3.2.21
ELSE : 3.2.20
- 3.2.20 : Notify the user that the quality flag on the salinity will be set to doubtful
: Set the quality flag on the salinity to "3", doubtful
: 3.2.24
- 3.2.21 IF: The quality flag on salinity is already set to be doubtful
THEN : 3.2.23
ELSE : 3.2.22
- 3.2.22 : Set the quality flag on the salinity to "2", inconsistent
: 3.2.24
- 3.2.23 IF: The user confirms that the quality flag on salinity should be changed from doubtful to
inconsistent
THEN : 3.2.22
ELSE : 3.2.24
- 3.2.24 IF: The quality flag on temperature is set to be erroneous
THEN : 3.2.14
ELSE : 3.2.25
- 3.2.25 IF: The quality flag on salinity is set to be erroneous
THEN : 3.2.14
ELSE : 3.2.26
- 3.2.26 IF: The salinity observation lies within 3 standard deviations of the climatological salinity at
the given temperature and location
THEN : 3.2.14
ELSE : 3.2.27
- 3.2.27 : Display the temperature-salinity profile with quality flags
: Display the climatological temperature-salinity profile and 3 standard deviations
: Display the temperature-salinity values and quality flags at the same depth range from
neighbouring stations

: 3.2.28

3.2.28 IF: The user chooses to set the quality flag on temperature and /or salinity to be inconsistent
THEN : 3.2.30
ELSE : 3.2.29

3.2.29 : Notify the user that the quality flag on the temperature and/or salinity will be set to
doubtful
: Set the quality flag on the temperature and/or salinity to "3", doubtful
: 3.2.14

3.2.30 IF: The quality flag on temperature and/or salinity is already set to be doubtful
THEN : 3.2.32
ELSE : 3.2.31

3.2.31 : Set the quality flag on the temperature and/or salinity to "2", inconsistent
: 3.2.14

3.2.32 IF: The user confirms that the quality flag on temperature and/or salinity should be changed
from doubtful to inconsistent
THEN : 3.2.31
ELSE : 3.2.14

3.2 Entry and Dewar Climatology
Part 1

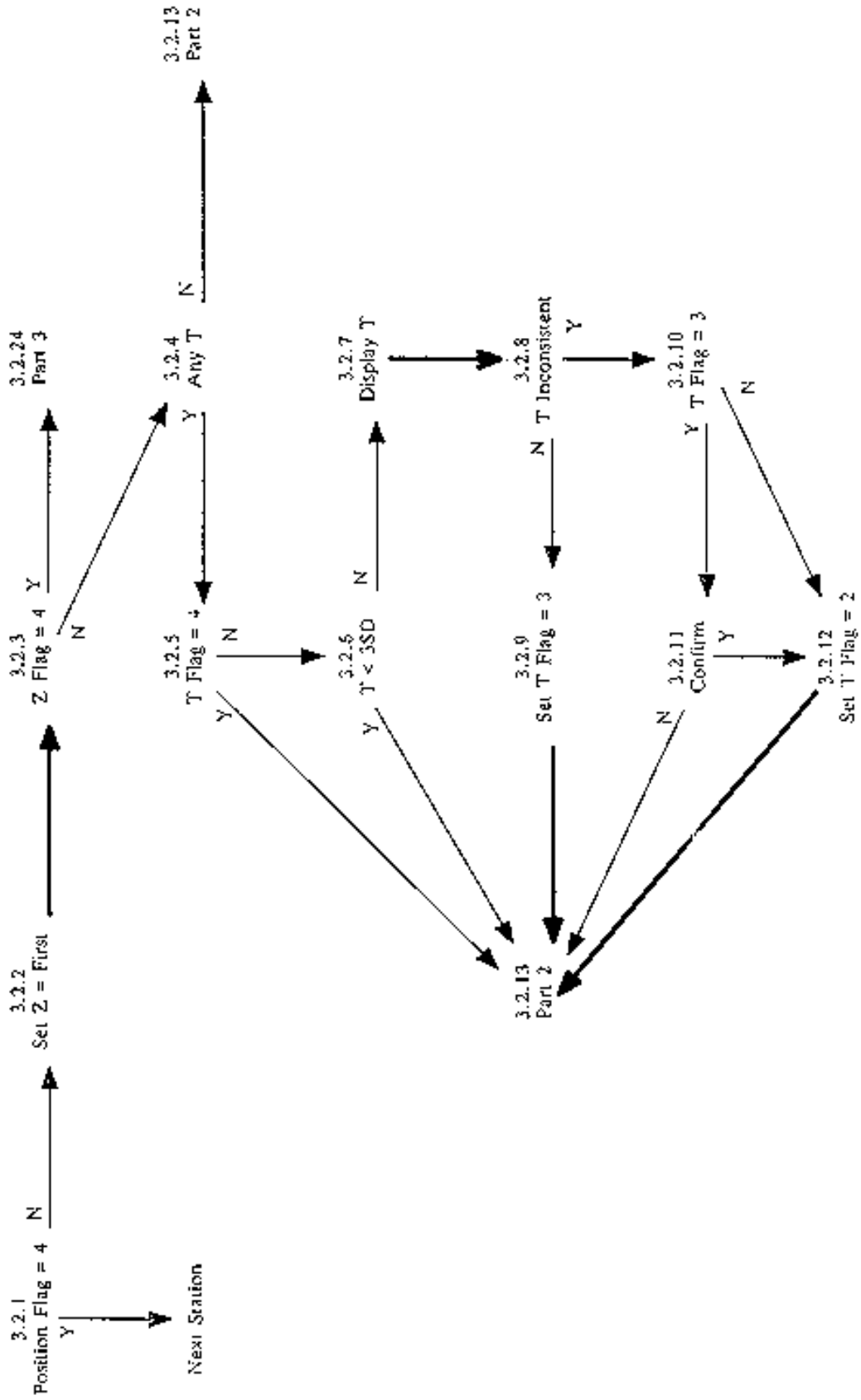

3.2 Emery and Dewar Climatology
Part 2

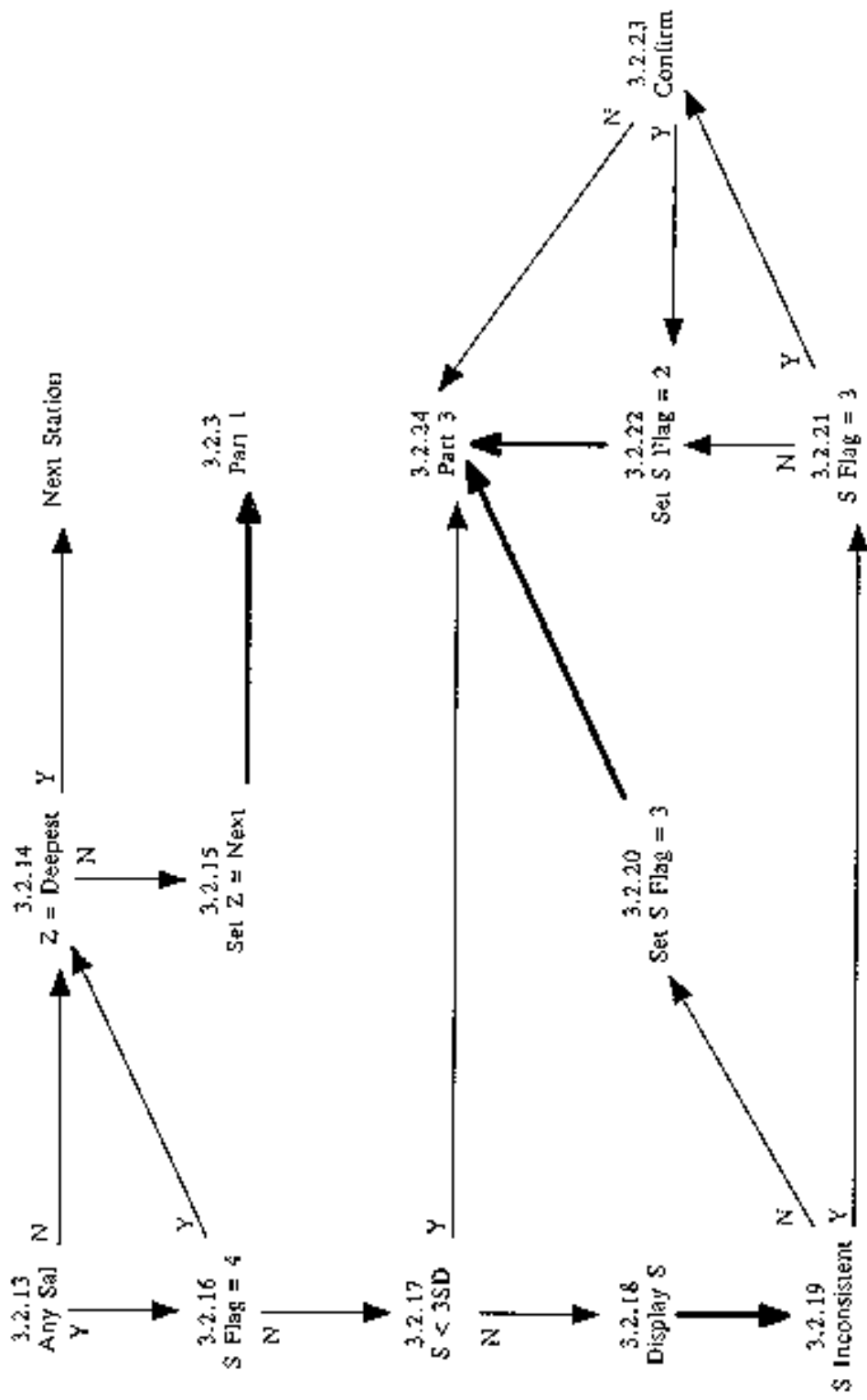

3.2 Emery and Dewar Climatology
Part 3

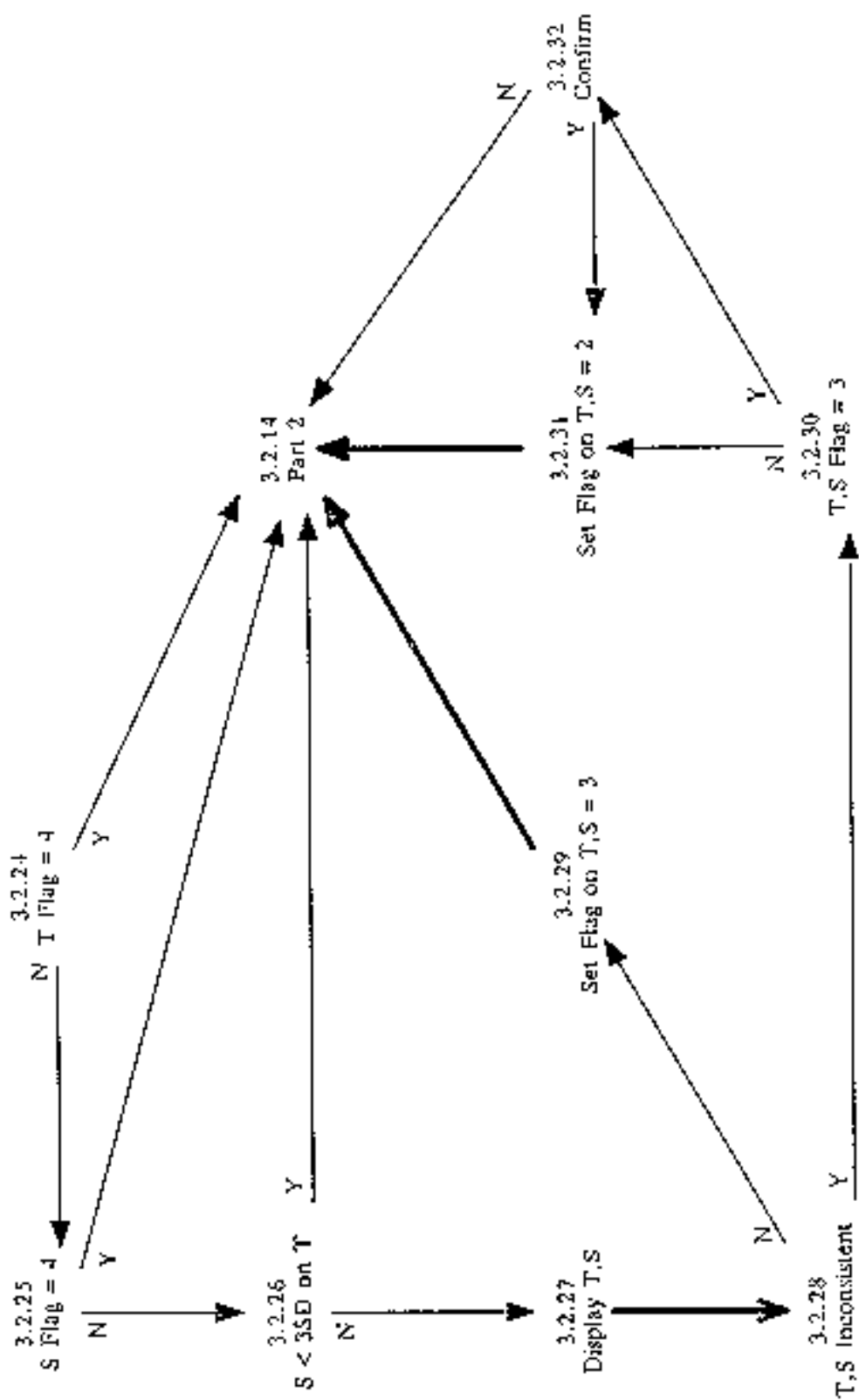

TEST NAME: 3.3 ASHEVILLE SST CLIMATOLOGY

Prerequisites: All of Stage 1 tests.
Global Impossible Parameter Value test.
The stations are sorted by latitude and longitude.

Description:

This test determines if the observed sea surface temperature lies within 3 standard deviations of the Asheville climatological mean for the given location and month.

The test starts by determining if any one of the latitude, longitude or month has a quality flag set to be erroneous. If so, the next station is tested. If not, but if there is no surface observation, the next station is tested. If there is a sea surface temperature observation but it has a quality flag set to be erroneous, the next station is tested.

If the surface temperature observation is fine, and it lies within 3 standard deviations of the climatological mean for the given location and month, then the next station is tested. If the observation lies outside of the limit, the surface value is displayed along with the climatological mean, 3 standard deviations from the mean, and surface temperatures from neighbouring stations. The user may then choose to set the quality flag to be inconsistent. If not, the flag is set to be doubtful.

If the user chooses to set the flag to be inconsistent, but the present value is already set to be doubtful, the user must confirm the flag be changed. If confirmed, the flag is changed from doubtful to inconsistent, otherwise it is left unaltered. After the quality flag has been set, the next station is tested.

History: None

Rules:

- 3.3.1 IF: Any one of latitude, longitude or month has a quality flag set to be erroneous
THEN : Test the next station
ELSE : 3.3.2
- 3.3.2 IF: There is an observation at the surface
THEN : 3.3.3
ELSE : Test the next station
- 3.3.3 IF: There is a surface temperature observation
THEN : 3.3.4
ELSE : Test the next station
- 3.3.4 IF: The quality flag on the temperature is set to be erroneous
THEN : Test the next station
ELSE : 3.3.5
- 3.3.5 IF: The temperature value lies within 3 standard deviations of the climatological mean at the given location in the given month
THEN : Test the next station
ELSE : 3.3.6
- 3.3.6 : Display the temperature and its quality flag
: Display the climatological temperature and 3 standard deviations
: Display surface temperatures from neighbouring stations in the same month
: 3.3.7
- 3.3.7 IF: The user chooses to set the quality flag on the temperature to be inconsistent
THEN : 3.3.9

ELSE : 3.3.8

3.3.8 : Notify the user that the quality flag on the temperature will be set to be doubtful
: Set the quality flag on the temperature to "3", doubtful
: Test the next station

3.3.9 IF: The quality flag on the temperature is already set to be doubtful
THEN : 3.3.11
ELSE : 3.3.10

3.3.10 : Set the quality flag on the temperature to be "2", inconsistent
: Test the next station

3.3.11 IF: The user confirms the quality flag should be changed from doubtful to inconsistent
THEN : 3.3.10
ELSE : Test the next station

3.3 Astreville SST Climatology

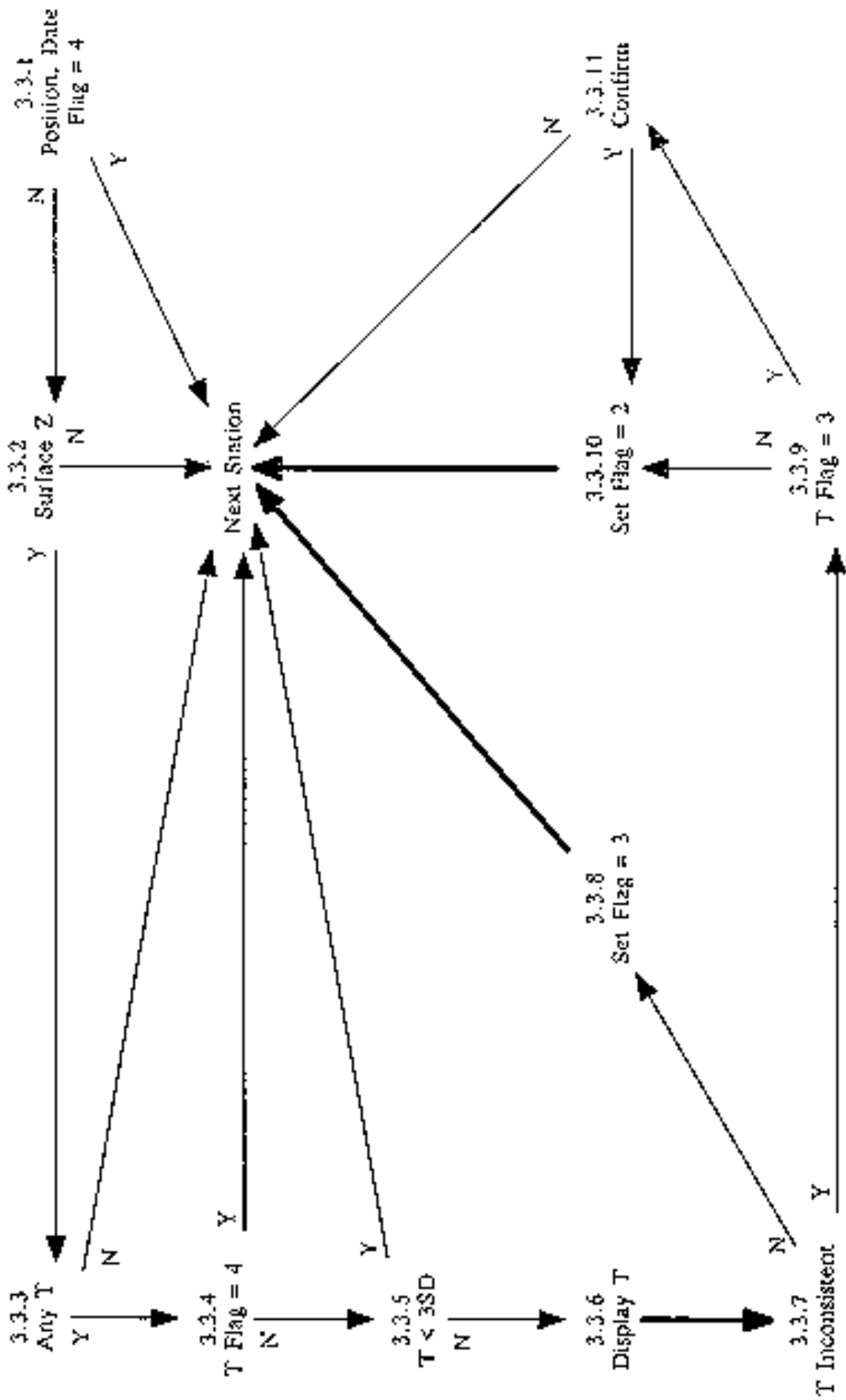

TEST NAME: 3.4 LEVITUS MONTHLY CLIMATOLOGY

Prerequisites: All of Stage 1 tests.
Global Impossible Parameter Value test.
The stations are sorted by latitude and longitude.

Description:

This test compares the mean and standard deviations of an observed profile to that of the Monthly Levitus climatology of temperature and salinity. If the values derived from the observations lie within a specified threshold then the observed profile is considered to have passed. The thresholds are given in table 3.4 below.

The test begins by ensuring that the quality flag on the latitude, longitude and month are not set to be erroneous. If any one is, the next station is tested. If not, the first depth is examined and the parameter under consideration is set to be temperature, or salinity if there is no temperature. The quality flag on the depth is tested to determine if it is set to be erroneous. If so, the depth is tested to see if it is the deepest. If it is not the deepest, the depth is set to be the next in the profile, the parameter to be the temperature or salinity as before and the flag tested on the depth. If the depth is the deepest, profile properties are tested as will be described later.

If the quality flag on the depth is not set to be erroneous. the quality flag on the parameter under consideration is examined. If the flag is set to be erroneous, the station is examined to determine if there is another parameter (salinity) available. If there is, the parameter value is set to be that for the next parameter and the quality flag tested as just described. If there are no more parameters, the depth is tested to see if it is the deepest in the profile and processing proceeds as described before.

If the depth is the deepest in the profile, the mean and standard deviation of the observed profile parameters are calculated and the same properties for the climatological profiles at the same location and month. Then if the absolute difference between the observed mean and the climatological mean of a given parameter exceeds the threshold set in table 3.4, display the information as will be described. If not, test if the absolute difference of the standard deviation of the observed profile from its mean to the same quantity as for the climatological profile exceed the threshold given in table 3.4. If not, repeat these tests for the next parameter at the station, or if there is no other, test the next station.

If the threshold is exceeded, display both the observed parameter profile, and the climatological mean. The user may then choose to set the quality flag on the parameter profile to be inconsistent. If the user denies this, the quality flag is set to be doubtful. If the user confirms the flag should be set to be inconsistent, but the flag is already set to be doubtful, the user must confirm the flags be changed. If confirmed, the flag on the parameter profile is changed from doubtful to inconsistent. If denied, no change of the quality flag is made. If the flag was not set to be doubtful, it is set to be inconsistent as the user chose to do. The next parameter is then tested or if there is no other parameter, the next station is tested.

Table 3.4 Thresholds (set on 20 April, 1990)

Parameter	Threshold
Mean temperature	0.5 degrees C
Mean salinity	0.2 PSU
Standard deviation of temperature	TBD
Standard deviation of salinity	TBD

Note: TBD = to be determined

History: None

Rules:

- 3.4.1 IF: Any one of the latitude, longitude or month has the quality flag set to be erroneous
THEN : Test the next station
ELSE : 3.4.2
- 3.4.2 : Set DEPTH to be the shallowest depth in the profile
: Set VALUE to be the temperature at DEPTH, or salinity if temperature is not present
: 3.4.3
- 3.4.3 IF: The quality flag on DEPTH is set to be erroneous
THEN : 3.4.4
ELSE : 3.4.6
- 3.4.4 IF: DEPTH is the deepest in the profile
THEN : 3.4.10
ELSE : 3.4.5
- 3.4.5 : Set DEPTH to be the next deeper in the profile
: Set VALUE to be the temperature at DEPTH, or the salinity if temperature is not present
: 3.4.3
- 3.4.6 IF: The quality flag on VALUE is set to be erroneous
THEN : 3.4.8
ELSE : 3.4.7
- 3.4.7 : Calculate the summed value of VALUE over the profile Calculate the summed difference
of the value at DEPTH from the climatological mean over the profile
: Sum the number of observations and means over the profile
: 3.4.8
- 3.4.8 IF: There is another parameter observed at DEPTH
THEN : 3.4.9
ELSE : 3.4.4
- 3.4.9 : Set VALUE to the value of the next parameter at DEPTH
: 3.4.6
- 3.4.10 : Set the summed value under consideration to be that for the first parameter
: Set the summed difference value under consideration to be that for the first parameter
: Set the number of values under consideration to be that for the first parameter
: 3.4.11
- 3.4.11 IF: The difference between the mean value of the observations of the parameter and the mean
value of the climatology is less then a specified threshold value, and the difference between
the standard deviation of the observations of the parameter and the standard deviation of
the climatology is less then a specified threshold value
THEN : 3.4.12
ELSE : 3.4.14
- 3.4.12 IF: There are summed values and summed differences for other parameters in the profile
THEN : 3.4.13
ELSE : Test the next station
- 3.4.13 : Set the summed value under consideration to be that for the next parameter
: Set the summed difference value under consideration to be that for the next parameter
: Set the number of values under consideration to be that for the next parameter
: 3.4.11

- 3.4.14 : Display the observed profile
: Display the climatological profile from the same location and month
: 3.4.15
- 3.4.15 IF: The user chooses to flag the parameter profile as inconsistent
THEN : 3.4.17
ELSE : 3.4.16
- 3.4.16 : Notify the user that the profile flag will be set to doubtful
: Set the quality flag on the profile to "3", doubtful
: 3.4.12
- 3.4.17 IF: The profile flag is already set to be doubtful
THEN : 3.4.19
ELSE : 3.4.18
- 3.4.18 : Set the quality flag on the profile to "2", inconsistent
: 3.4.12
- 3.4.19 IF: The user confirms that the quality flag on the profile should be changed from doubtful to
inconsistent
THEN : 3.4.18
ELSE : 3.4.12

TEST NAME: 4.1 WATERFALL

Prerequisites: All of Stage 1 tests.
Global Impossible Parameter Value test.
Sort the stations in the incoming file by identifier and date and time for each identifier

Description:

This test examines adjacent profiles in an incoming file to determine if they are similar in form. It does so by computing the difference of each profile from its mean and then comparing these differences. If they lie below a given threshold, the profiles pass the test. In order to do this test, the profiles must be interpolated to the same set of depths. The Reineger-Ross interpolation scheme is used and only those points and depths with quality flags not set to be erroneous are used. As well, it is considered that the two profiles must be collected within 500 kilometers and 5 days of each other.

The test begins with the first identifier in the file. All of the stations with this identifier are examined to compose a list of the available parameters. Then, the first parameter is selected. The first station is tested to determine if a profile exists for the parameter under consideration. If it does not exist, the station is checked to see if it is the last for the identifier. If it is not, the next station is tested to see if a profile for the parameter exists.

If the station is the last for the identifier, the parameter is checked to determine if it is the last of the list of available parameters. If not, the parameter to be considered is set to be the next on the list, a marker (used to indicate a first profile of a pair has been found) is cleared and the station under consideration set to be the first for the identifier. The station is tested to see if a profile exists for the parameter and processing continues as already described.

If the parameter was the last on the list for a particular identifier, then the identifier is checked to see if it is the last in the file. If not, the identifier under consideration is set to be the next in the file. Then the list of available parameters for this identifier is composed and processing continues as already described. If it was the last identifier, this test is complete.

If a profile exists for the parameter in question, the marker is checked to see if it is set. If not, the marker is set and the profile is assigned to be the first in the pair to be considered. Then, the station is checked to see if it is the last for the identifier and processing continues as already described.

If the marker was already set, the profile being considered is assigned to be the second in the pair to be considered. The two profiles are then tested to determine if they have been collected within 500 kilometers and 5 days of each other. If not, the first profile is discarded and the second profile is assigned to be the first of a new pair. The station is then checked to see if it was the last for that identifier and processing continues as described above.

If the two profiles were collected sufficiently close together in time and space they will be interpolated in depth to the same set of standard depths. If quality flags on the individual depths of parameter values are set to be erroneous, then they are not used in the interpolation. Once the interpolation is complete, the mean of each profile is calculated. The test proceeds by examining one depth at a time beginning with the shallowest. The mean is subtracted from the interpolated value for each profile respectively and then the two differences are subtracted. This absolute value of the result is checked against the threshold for the parameter, given in table 4.1 below. If it lies below the threshold, the depth is examined to see if it is the deepest in the profiles. If it is not, the values at the next depth are examined as described above. If it is the deepest, the first profile is discarded, the second set to be the first in the pair and processing proceeds as already described.

If the result exceeds the threshold, the two profiles are displayed as well as any other from the same identifier that lie within 500 kilometers and 5 days of either of the two profiles in the pair. Also displayed are the interpolations to the two profiles. The user can then choose to set the quality flag on

the second profile. If not, the quality flag on the first may be set. If not, the depth is tested to determine if it is the deepest and processing continues as previously described.

If the user chooses to set the quality flag on either of the profiles, the same process is followed. First the user can choose to set the flag to be inconsistent. If so, the flag is checked to ensure it is not already set to be doubtful. If not, the flag is set to be inconsistent and the depth tested to be the deepest. If the flag was already set to doubtful, the user must confirm that it be changed from doubtful to inconsistent. If confirmed, the change is made. If not confirmed, or if the user chose not to flag the profile as inconsistent, the user can now choose to flag it as doubtful. If denied, the flag remains unaltered. If accepted, the flag is set to doubtful, and the depth tested to determine if it is the deepest in the profiles. Further processing from here has already been described.

Table 4.1 Thresholds for absolute differences between parameter values in a pair of profiles.

Parameter	Threshold
Temperature	0.5 degrees C
Salinity	0.3 PSU

References:

1. Reiniger, R.F. and C.K. Ross, 1968. A method of interpolation with application to oceanographic data. Deep Sea Research, V15, pp185-193.

History: None

Rules:

- 4.1.1 : Set ID to the first identifier in the list in the incoming file
: 4.1.2
- 4.1.2 : Derive the list of parameters for all of the stations with the given identifier
: Set PARM to be the first in the list of parameters
: 4.1.3
- 4.1.3 : Set the station under consideration to be the first
: 4.1.4
- 4.1.4 IF: There is a profile of the given PARM for this station
THEN : 4.1.11
ELSE : 4.1.5
- 4.1.5 IF: The station is the last with this identifier
THEN : 4.1.7
ELSE : 4.1.6
- 4.1.6 : Set the station under consideration to be the next for this identifier
: 4.1.4
- 4.1.7 IF: PARM is the last of the list of parameters for the given identifier
THEN : 4.1.9
ELSE : 4.1.8
- 4.1.8 : Set PARM to be the next in the list for the given identifier
: Clear MARK
: 4.1.3
- 4.1.9 IF: The identifier under consideration is the last one in the file
THEN : Test the next station

ELSE : 4.1.10

4.1.10 : Set ID to be the next identifier in the incoming file
: 4.1.2

4.1.11 IF: The profile has the quality flag set to be erroneous
THEN : 4.1.5
ELSE : 4.1.12

4.1.12 IF: MARK has been set
THEN : 4.1.14
ELSE : 4.1.13

4.1.13 : Set MARK
: Set PROFILE1 to be the present profile
: 4.1.5

4.1.14 : Set PROFILE2 to be the present profile
: 4.1.15

4.1.15 IF: PROFILE1 is within 500 kilometers and 5 days of PROFILE2
THEN : 4.1.17
ELSE : 4.1.16

4.1.16 : Set PROFILE2 =PROFILE 1
: 4.1.5

4.1.17 :Interpolate the data for both PROFILE1 and PROFILE2 so that the data are represented at the
same depths Calculate the mean of each profile
: Set DEPTH to be the first in the profiles
: 4.1.18

4.1.18 : Calculate the difference between the mean and the value at DEPTH for PROFILE1, call it
DIFF1
: Calculate the same quantity for PROFILE2, call it DIFF2
: 4.1.19

4.1.19 IF: The absolute value of DIFF1 minus DIFF2 is less than a given threshold
THEN : 4.1.20
ELSE : 4.1.22

4.1.20 IF: DEPTH is the deepest in the profiles
THEN : 4.1.16
ELSE : 4.1.21

4.1.21 : Set DEPTH to be the next in the profiles
: 4.1.18

4.1.22 : Display PROFILE1
: Display PROFILE2
: Display profiles of the same parameter for the same identifier that are within 500
kilometers and 5 days of either PROFILE1 or PROFILE2
: 4.1.23

4.1.23 IF: The user chooses to set the quality flag on PROFILE2
THEN : 4.1.25
ELSE : 4.1.24

- 4.1.24 IF: The user chooses to set the quality flag on PROFILE1
THEN : 4.1.25
ELSE : 4.1.20
- 4.1.25 IF: The user chooses to set the quality flag on the profile to be inconsistent
THEN : 4.1.26
ELSE : 4.1.29
- 4.1.26 IF: The quality flag on the profile is already set to be doubtful
THEN : Notify the user how the flag is presently set
: 4.1.28
ELSE : 4.1.27
- 4.1.27 : Set the quality flag on the profile to be "2", inconsistent
: 4.1.16
- 4.1.28 IF: The user confirms that the quality flag should be changed
THEN : 4.1.27
ELSE :4.1.29
- 4.1.29 IF: The user chooses to set the quality flag on the profile to be doubtful
THEN : 4.1.30
ELSE : 4.1.16
- 4.1.30 : Set the quality flag on the profile to be "3", doubtful
: 4.1.16

4.1 Waterfall Test
Part 1

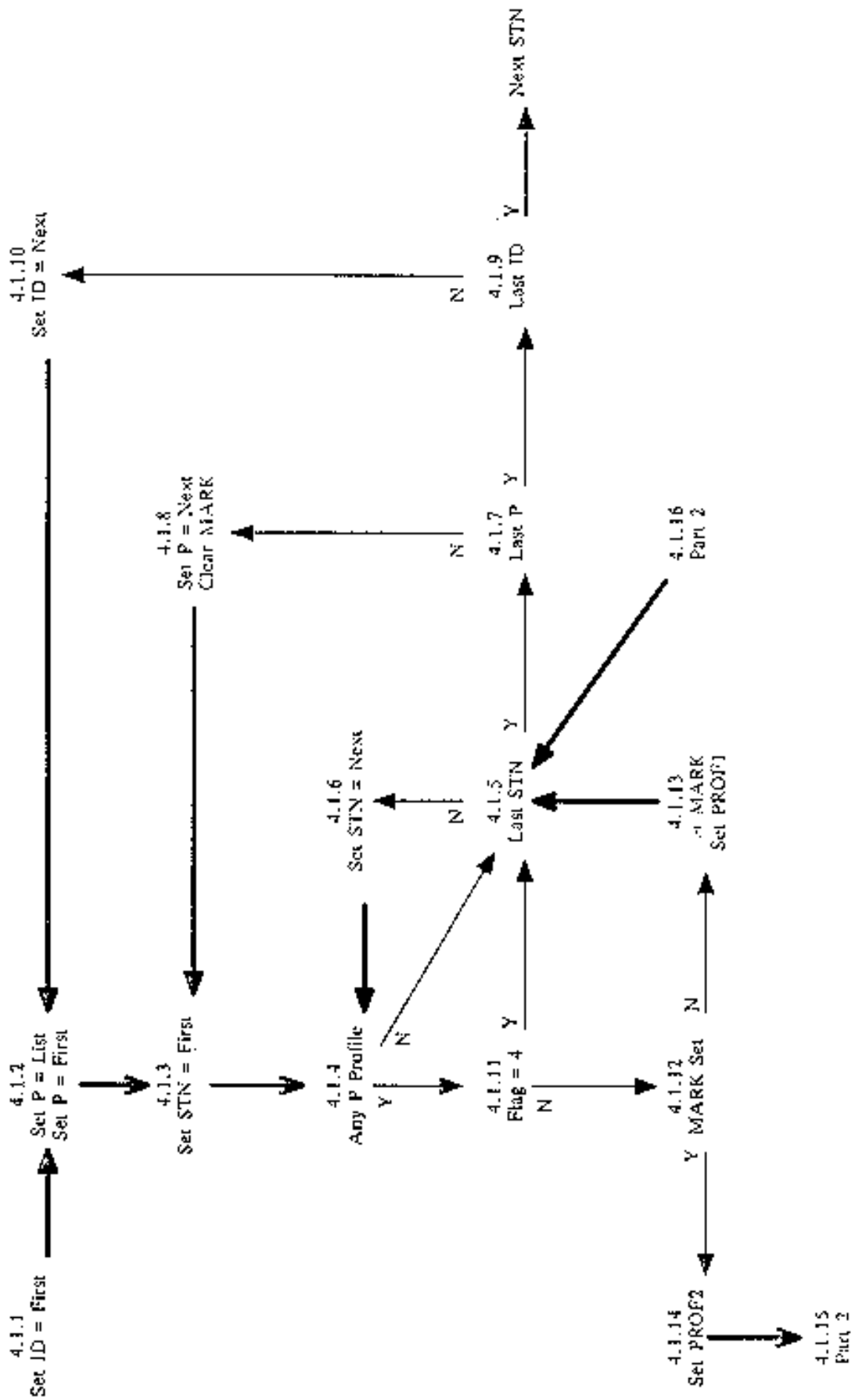

4.1 Waterfall Test
Part 2

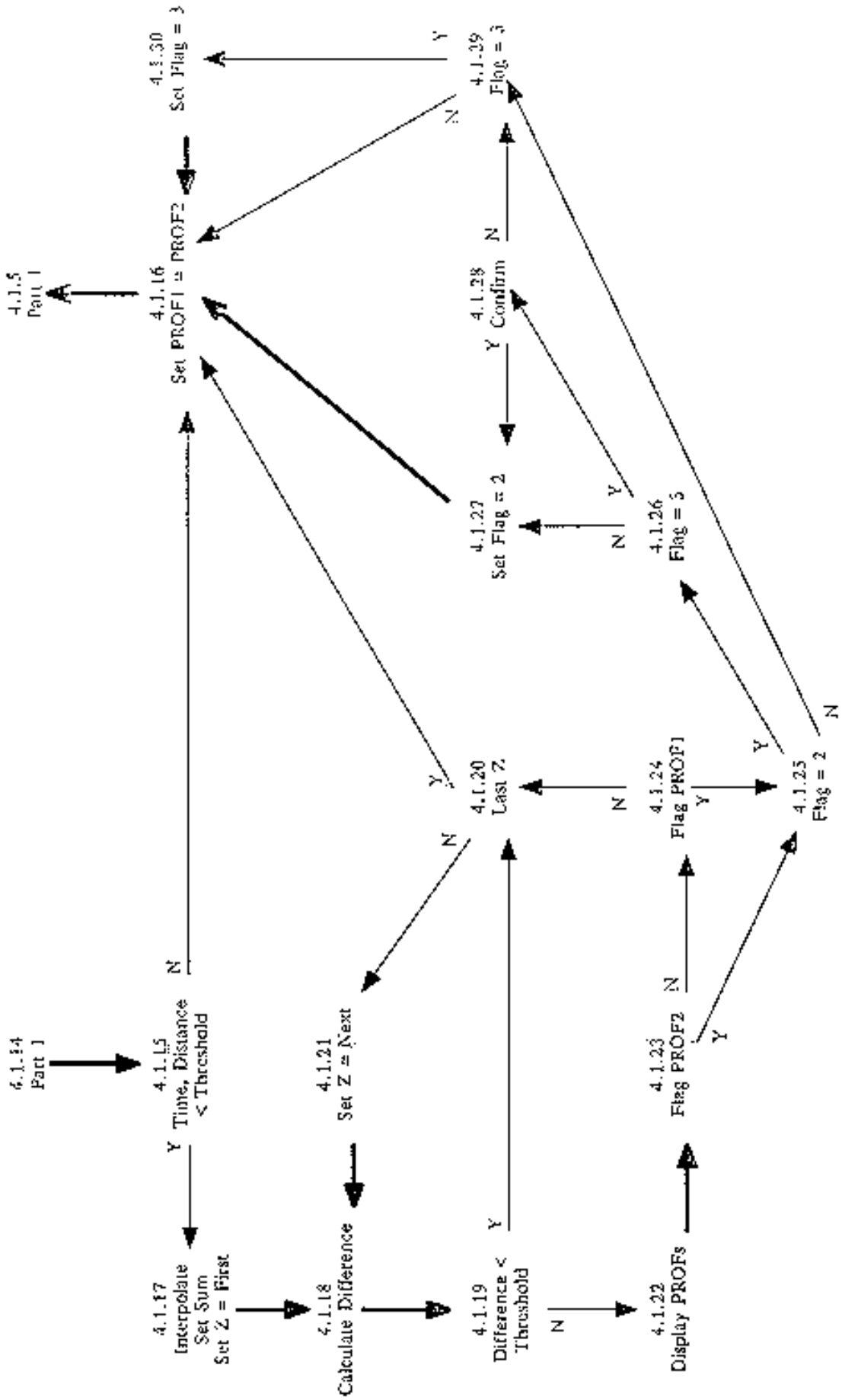

TEST NAME: 5.1 CRUISE TRACK**Prerequisites:** None**Description:**

This test involves the visual inspection of the data as received at the processing centre. The stations of observations should be arranged in what constitute "cruises". For data received in real-time, a cruise would be the collection of stations from a single ship and arranged in chronological order of collection. The cruise track for each is plotted showing the location of each station and a coastline map of the region. The person reviewing it should satisfy themselves that the stations do not appear to follow in an appropriate sequence and relationship to each other.

History: None**Rules:** None**TEST NAME: 5.2 PROFILES****Prerequisites:** None**Description:**

The profiles of the observations should be viewed at each station. This review will identify any questionable variations in the parameters and set quality flags as appropriate. In special cases, where further information is available, or where the error and necessary correction are beyond doubt, the person conducting the review may alter the data value. Should this occur, the quality flag must be set to "5" to indicate the value was changed, and the original value is retained elsewhere in the record.

Processing centres may choose to calculate other variables based on those received in order to help assess the observed values. For example, a calculation of the density profile based on temperature and salinity, will help to determine if the observed values are reasonable. There are numerous other possibilities. Processing centres should be prepared to supply written documentation of the procedures employed in this stage of processing.

History: None**Rules:** None

ANNEX C: SUGGESTED ADDITIONAL TESTS

This annex contains a brief description of other tests to be considered in future versions of the Quality Control Manual. Contributions have come from various sources. They are presented in no particular order.

1. When information is available, use forecast fields to compare to incoming data. Those data mismatching the forecast require closer looks.
2. AODC check that sea surface reference temperature agrees to XBT surface value to within 3 degrees.
3. AODC suggests additions to Impossible Parameter Values.

PARAMETER	MIN	MAX
Cloud Code	0	9
Air Pressure	950	1050mb
Weather Code	0	9
Wave Period Code	0	20
Wave Height Code	0	60

4. We could use a test that takes the position of a profile and uses the fact that it is near a source of freshwater to refine the permissible salinity limits. This would be a refinement of range tests based on regions.
5. VNIIGMI-WDC suggests the use of statistical criteria on data accumulated over one month, in a region of 5 or 10 degrees squares and at standard depths. The individual observations are then tested to see if they exceed 3 standard deviations based on the distribution of values. It is suggested that either the Tukey or Dickson criteria could be used. These are described in "Exploratory Data Analysis" by J.W. Tukey, Addison and Wesley, 1977, pp693 and in "Statistische Auswertungsmethoden" by L.Sachs, Springer, 1972, pp598.
6. DHI has suggested that a water mass test be employed. This could either be a comparison of TS curves to a climatology (as is partly done in test 3.2) or as a comparison to volumetric analysis compiled for various ocean areas.

SECTION 2.9

CEC-IODE/IOC Meeting on Quality Standards

IOC, Paris, 21 January 1991

Brief Synopsis of Procedures at the ICES Oceanographic Data Centre, Copenhagen.

Background:

1. The Data Centre receives, annually, ca 10,000 stations of CTD/water bottle/nutrient data from many different sources in its member countries. About 10% of these data arrive via national data centres, and 20% are data from projects which utilize ICES as their data centre.
2. About 90% of submissions are in "unapproved" formats or on manuscript which have to first be converted to facilitate routine checking activities. The resource required to do this is greater than that devoted to quality control.

Quality Control:

1. Consistency checks, requiring close checking with other sources of information, e.g., cruise summary reports. This is to eliminate factors that would not normally be identified by Quality control. Examples are (1) use of helicopters from research ships which invalidates speed check criteria and (2) faults in suppliers software failing to clear fields with no data - one data submission had almost 800 stations of silicate data, when only 265 were actually worked. Modern exchange systems, e.g. GF3 /JGOFS /Blueprint are also easily capable of supplying the wrong data with the wrong parameter.
2. No data at ICES are flagged for quality, all queries. are referred back to the originator for resolution or removal of data. Where whole cruises are of doubtful quality, such information is recorded in the cruise information files.
3. Station header information is checked by (1) track charts, (2) speed checks, and (3) correct sounding (if given). Prior to this specific checking, elementary checks, such as no more than 59' in a degree or hour, are undertaken. This is a common problem. Checks concerning sounding in relation to bottom sampled depth sometimes reveal that wire out, rather than depth (pressure) of sample has been reported.
4. Data cycle checks include: property-property plots by submission and comparison with other submissions. This reveals problems with, e.g., the leading figure being left out of salinity data. This also serves to identify outliers and particularly 'noisy' data. It also facilitates the identification of sample bottles being mixed up - e.g. the salinity and/or chemical samples being drawn in incorrect order. This latter error is also often identified in the density inversion checks which are an important element of the ICES quality procedures. Inversion checks are however utilized cautiously as failures are biased to vertically homogeneous water.

APPENDIX 1 BIBLIOGRAPHY

The following documents contain standards and information relevant to quality control of oceanographic data.

Manual of International Oceanographic Data Exchange, 1991. UNESCO, IOC-ICSU, Manuals and Guides No.9.

Guide to Drifting Data Buoys, 1988. UNESCO, IOC-WMO, Manuals and Guides No.20.

Quality Assurance in Marine Monitoring, Chemical Analysis, 1992. CEC, Community Bureau for Reference, Report EUR-14297.42pp.

Caldwell, P.C., 1991, Sea level data processing software on IBM PC compatible microcomputers. TOGA Sea Level Center. April 1991.

Wyrski, K., et al., 1988, The Pacific Island Sea Level Network. joint Institute for Marine and Atmospheric Research, University of Hawaii, JIMAR contribution no. 88-0137.

Manual on Marine Meteorological Services, 1981, Volume 1. Global Aspects. WMO. No.558.

Manual on Sea Level Measurement and Interpretation, 1985. UNESCO, IOC. Manuals and Guides No.14.83pp.

IHO Standards for Hydrographic Surveys and Classification Criteria for Deep Sea Soundings. 1982. IHB. Monaco. Special Publication No.44. 21 pp.

Lowry, R. K., 1990, North Sea Project Data Base Users' Guide, 1990. British Oceanographic Data Centre, 51pp.

Rickards, L.J. 1985. Report on sea level data collected during the MEDALPEX Experiment from 1st September 1981 to 30th September 1982. IOS Report no.209. (PSMSL). 170 pp.

Directions for Internationally Compatible Environmental Data, 1989. G.C.Carter (Ed.) A CODATA Workshop, McGill University, 1986, CODATA Bulletin, V.21. Numbers 1-2.217pp.

Carter D.J.T., 1990, Development of procedures for the analysis of ERS-1 radar altimeter dwind and wave data using Geosat data. ESA contract study report contract 8315/89/HGE-1. 77pp.

Allan T.D., (ED), 1992, Guide to Satellite Remote Sensing of the Marine Environment, IOC Manuals and Guides, No.24.

Tucker, M.J., 1992. Recommended Standard for wave data sampling and near-real-time processing. Oil Industry International Exploration and Production Forum. Report 3.14/186. 77pp.

UK ERS1 Reference Manual. 1991 RAE Farnborough reference: DC-MA-EOS-ED-001. Edited by Vass, P., and Handoll, M. (And equivalent documents in other ESA countries).

Halpern, D., Knauss, W., Brown, and Wentz., 1992. An atlas of monthly mean distributions of SSMI surface wind speed, ARCOS buoy drift, AV14RIZ/2 sea surface temperature, and ECMWF surface wind components during 1989. NASA - JPL, Publication 92-17.112 pages (single sides numerated).

Unesco 1981. Background papers and supporting data on the International Equation of State for seawater 1980. Unesco/ ICES/ SCOR/ IAPSO joint panel on oceanographic tables and standards. Unesco technical papers in marine science No. 38. 192pp.

JPOTS 1991. Processing of oceanographic station data. Unesco/ ICES/ SCOR/IAPSO. 138 pp.